

# PENINSULA BOOTH

**PRI**SHOW

**\* ALL PENINSULA EXHIBITORS ARE REQUIRED TO SUBMIT ACCURATE RENDERINGS AND DIMENSIONS OF THE PENINSULA EXHIBIT TO SHOW MANAGEMENT FOR APPROVAL PRIOR TO THE SHOW.**

(For questions, please contact Tiffany Hale at 949.373.9248 or email: tiffanyh@performanceracing.com)

## DEFINITION

Exhibit with four or more 10' x 10' standard units back to back with an aisle on three sides. Exhibitor cannot create an island effect with flooring variation, within 10 linear feet of a neighboring exhibitor.

## INTENT

Peninsula booths are normally faced toward the cross aisle. However, if you wish to have a different configuration, Show Management must approve your booth designs.

## HEIGHT\*

The maximum height permitted for any non-hanging sign, display, product, fixture, or decoration within the exhibit is 16'.

## DIMENSIONS

Exhibit structures must be constructed to allow 9" for utility service access at the rear, i.e. a 20' x 30' exhibit space has 29' 3" usable space from front to back wall.

## LINE-OF-SIGHT

Line-of-sight display rules provide restrictions on certain areas of booths to allow attendees to view neighboring booths in their line of sight as they walk the floor. The ability to have products or services easily seen by attendees as they walk the aisles is essential to all exhibitors and that is the basis for linear booth line-of-site setback rule.

## GRAPHICS

Signage and Graphics facing directly into a neighboring booth over the 8' high drape must be free of graphics or signage.

## FINISHED BOOTH SURFACES

Peninsula exhibits must have a finished back wall and finished sides. Plain drape or unfinished hard-walls are not permitted. Drape and hard-wall may be silk-screened with company identification. Any portion of the exhibit bordering another exhibitor's exhibit space must have the back side of that portion finished, and must not have any company identification.

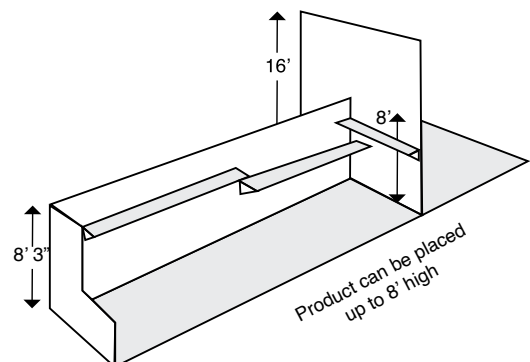
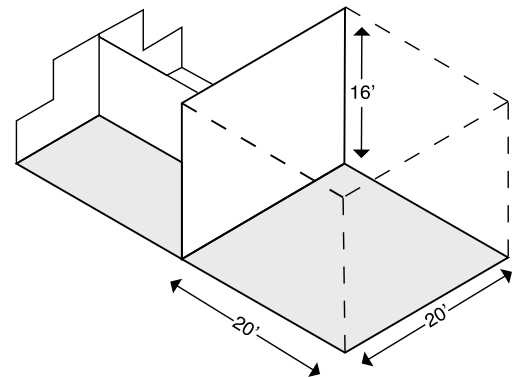

## **AISLE CARPET**

Exhibitor carpet must not extend out past the show aisle carpet.

## **BOOTH POLICY**

PRI reserves the right, in its sole and absolute discretion, to determine who will be permitted to display products as an exhibitor, and the size, location and configuration of exhibition space for which the application is made. Exhibiting at prior shows, nature of product displayed, number of booths requested and other factors may influence, but does not guarantee, location of exhibition space. Change to booth locations may occur at any time from the initial assignment through show opening. Modifications to an exhibitor's display, including, but not limited to fixture placement, material display, material distribution, model's attire, and noise levels, may be made by PRI Show Management at any time.

## **BRIDGING PENINSULAS**

An exhibitor may "bridge" the aisle between two side-by-side peninsula booth spaces in accordance with the following regulations:

- Minimum height – 10'
- Maximum height – 16'
- The actual bridge structure may not exceed 4' in height.
- The "bridge" must be a bona fide structural component of the booth, such as a roof.
- Signs and banners are prohibited unless they conform to the architectural integrity of the booth and the bridge.
- Architectural renderings must be submitted and approved by Show Management at least three months prior to the first day of the show.