

VOLUME 39 | NUMBER 12 | DECEMBER 2024

# PRRI

PERFORMANCE RACING INDUSTRY MAGAZINE

## 2025 BUYERS GUIDE

INSIDE

HUNDREDS OF RACE COMPONENTS | LATEST TECHNOLOGY  
TOOLS & EQUIPMENT TO IMPROVE YOUR BOTTOM LINE

# ...BUT YOUR ENGINE IS CLEAN



- Eliminate Engine Varnish
- Reduce Deposit Buildup
- Increase Performance
- Decrease Operating Temperatures
- Conquer Your Home Track





# YOUR COMPETITIVE ADVANTAGE

**TURN14**  
DISTRIBUTION

x

**RANCHO**  
PERFORMANCE SUSPENSION & SHOCKS

## RS5000X SHOCK

Turn 14 Distribution is the premier B2B source for Rancho Off-Road Shocks, Struts & Lift Kits. As a valued dealer, we provide you with access to industry-leading customer support, real-time inventory, flat rate shipping from our strategically located distribution centers, and 100% hassle-free returns.

100% WHOLESALE | [TURN14.COM](http://TURN14.COM)

# CONTENTS

DECEMBER 2024 VOLUME 39, NUMBER 12

# PRI

MAGAZINE



## Engine Components ..... 8

Powerplant upgrades galore are featured in this section, including alternators, crankshafts, oil system components, radiators, valvetrain, and much more.



## Chassis, Driveline & Suspension ..... 60

Everything needed to build a race car, including brakes, driveline components, rod ends, shocks and springs, plus many others.



## Racing Components, Accessories & Services 90

From safety gear to oil, and trailers to sensors, this category is designed for the products and services to complete a race program.

## Machinery, Tools & Equipment ..... 120

Outfit the race shop, trailer, and pit area with the tools and equipment needed to work on engines, build race cars, and resolve those last-minute fixes to get the car back on the track quickly.



## Race Track Equipment ..... 144

Improve the racer and spectator experience with these upgraded products specifically for use at the race track.

## Sanctioning Bodies ..... 148

A comprehensive list of national and local sanctioning organizations that regulate and coordinate the various events and series that fall under their authority.

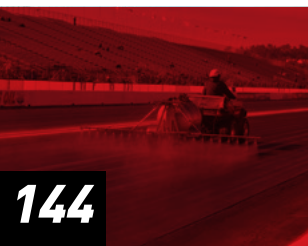

## Manufacturers' Representatives ..... 164

Look to these manufacturers' reps when seeking new product lines, searching for the latest news about racing trends, or desiring business advice from a proven industry veteran.

## Warehouse Distributors ..... 168

Suppliers can quickly connect to speed shops and engine builders through warehouse distributors, which offer plenty of storage space along with helpful customer service teams, online ordering, one-day shipping, and other useful services.



## Suppliers Index ..... 174

Reference and contact information for hundreds of leading product suppliers representing all forms of motorsports.

## DEPARTMENTS

Performance Industry Reps ..... 184

Advertisers Index ..... 185



COVER IMAGERY: Photo by James J. Black

### PRESIDENT

Michael Good

### GENERAL MANAGER

Jim Liaw

### EDITORIAL

#### EDITORIAL DIRECTOR

Jason Mulrone

#### EXECUTIVE EDITOR

Meredith Kaplan Burns

#### CONTENT EDITOR - DIGITAL

Laura Pitts

#### ASSOCIATE EDITOR

AJ Hecht

#### CONTRIBUTORS

Drew Hardin, Jack Haworth, Mike Magda

### SALES

#### VICE PRESIDENT OF SALES

Warren Kosikov

#### SENIOR SALES DIRECTORS

Alan Josse

Brian Paik

#### INDUSTRY SALES DIRECTORS

Amy Bartz-Simmons

Scott Hartwick

Becca Butler

Celina Kluba

Jeff Dahlin

Willie Yee

Julie Freier

#### EXECUTIVE ASSISTANT, SALES & PROJECT MANAGER

Madison Danna

#### SALES ASSISTANTS

Mary Crum

Lisa Schafer

Karina Mendez

### PRODUCTION

#### GROUP OPERATIONS MANAGER

Janet Lee

#### ASSOCIATE ADVERTISING COORDINATOR

Abbie Goshen

### ART

#### SENIOR ART DIRECTOR MANAGER

Paul Graff

#### GRAPHIC DESIGNER

John Cabral

### PHOTOGRAPHERS

Michael Allo, James J. Black, Meredith Kaplan Burns,

Mike Campbell, Christen D'Alessandro, John Lee

### ACCOUNTING

#### PAYABLES

Lily Huang

*Performance Racing Industry* (ISSN 1045-3024) is published monthly in the interest of the growth and development of the racing market, consisting of manufacturers, retailers and racing participants. *Performance Racing Industry* can be contacted at 1575 S. Valley Vista Dr., Diamond Bar, CA 91765-0910, 949/499-5413, Fax 949/499-0410. © 2024 Performance Aftermarket Publications, Inc. All rights reserved. This notice not only serves as a warning to potential infringers, but it is also required in order to enforce infringing acts under certain international treaties. Periodicals Postage paid at Pomona, CA 91769, and additional mailing offices. **Postmaster:** Send address change to *Performance Racing Industry*, 1575 S. Valley Vista Dr., Diamond Bar, CA 91765-0910. No part of this magazine may be reproduced without written consent of the publisher who is not responsible for the unsolicited material. *Performance Racing Industry* is sent to the retailers, distributors, manufacturers and racing participants within the United States. Subscriptions are complimentary to qualified members of the racing industry. "Performance Racing Industry" is a trademark owned exclusively by SEMA.

Printed in U.S.A.

PM # 40702022, Return Undeliverable Canadian Addresses to: Station A, PO Box 54, Windsor, ON N9A 6J5, Email: cpcreturns@wdmsmail.com

# Be last.

Being the last on the brakes isn't just a test of skill, it's also a test of how much confidence a driver has in their brakes.

With unique **Fade Resistant Technology™**, **Halo P1** has a far lower and far more stable level of compressibility over a wide temperature range than the competition—giving drivers the confidence that their brake fluid will perform as well on the last lap as the first.

**Formulated for the art of braking.**

**halo.**  
By Orthene.

[halobyorthene.com](http://halobyorthene.com)



MICKEY THOMPSON



TIRES & WHEELS

UNDISPUTED

TRACTION

FOR STREET, DRAG,  
TRUCK, AND EXTREME  
OFF-ROAD.

SEE US AT  
BOOTH #3831



# DRIVE TAKES YOU FURTHER

**GOODYEAR**  
MORE DRIVEN.

Goodyear celebrates drivers and teams that move beyond what's possible to reach their highest potential.



SPORTSCAR & FSAE DRAG & LANDSPEED

Goodyear Company. All Rights Reserved.



SECTION

1

# ENGINE COMPONENTS

Looking to enhance your engine program? The suppliers on the following pages are devoted to boosting or preserving horsepower. From engine blocks to radiators, and cams to superchargers, these components just may be the solution needed to kick up performance during the 2025 race season.



# SPEED

RUNS IN  
THE FAMILY



**PROXES RS1**  
Full-slick competition



**PROXES RR**  
DOT competition



**PROXES RA1**  
DOT competition



**PROXES R888R**  
DOT competition



**PROXES R1R**  
Extreme performance summer



**TOYO TIRES**<sup>®</sup>

# ARP (AUTOMOTIVE RACING PRODUCTS)

arp-bolts.com | 800-826-3045

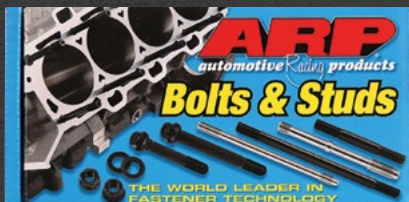

## AUDI 2.5L TFSI INLINE 5 CUSTOM AGE 625+HEAD STUD KIT

- 12 - ARP Custom Age 625+ Head Studs
- Centerless ground for increased concentricity
- Heat-treated prior to thread rolling and machining for increased fatigue strength
- 12 - ARP 12-pt. Flange Nuts and 12 - ARP Cat's Paw Washers
- 8740 hardened chromoly steel
- Block side has textured pattern that helps prevent washer spin during tightening to specified torque
- 8740 chromoly rated at 190,000 psi rated at 260,000 psi minimum tensile strength ARP Kit # 404-4708



## RING COMPRESSOR 86.25 MM (ARP KIT #-901-8625)

- ARP's ring compressors are CNC machined from 6061-T6 billet tube material
- Feature a true radius for each different bore diameter
- Incorporates a wire O-ring relief
- Type 3 anodizing is used for long life, and the bore size is prominently engraved in 3/4" high numbers for easy identification
- Standard stocking sizes from 3.552 to 4.750 (SAE) and 75 mm to 95.5 mm (metric)
- True radius design is superior to conventional "tapered" devices



## GMC 6.6L DURAMAX L5P, CAP SCREW ROD BOLT KIT (ARP KIT # 230-6302)

- 16 - ARP2000 Rod Bolts
- Centerless ground for increased concentricity
- Heat-treated prior to thread rolling and machining for increased fatigue strength
- Rated at 220,000 psi minimum tensile strength



## ARP 135-7903 BIG BLOCK CHEVY OIL PUMP DRIVE FOR .400 RAISED CAMSHAFT

- Made from premium grade 8740 and heat-treated to 190,000 psi
- ARP uses a unique manufacturing process where the alignment sleeve is roll formed onto the shaft (not welded or pinned), enabling the sleeve to float, allowing for slight misalignment



# **ERACING** wilwood

## FEATURED PRODUCTS AT PRI 2024

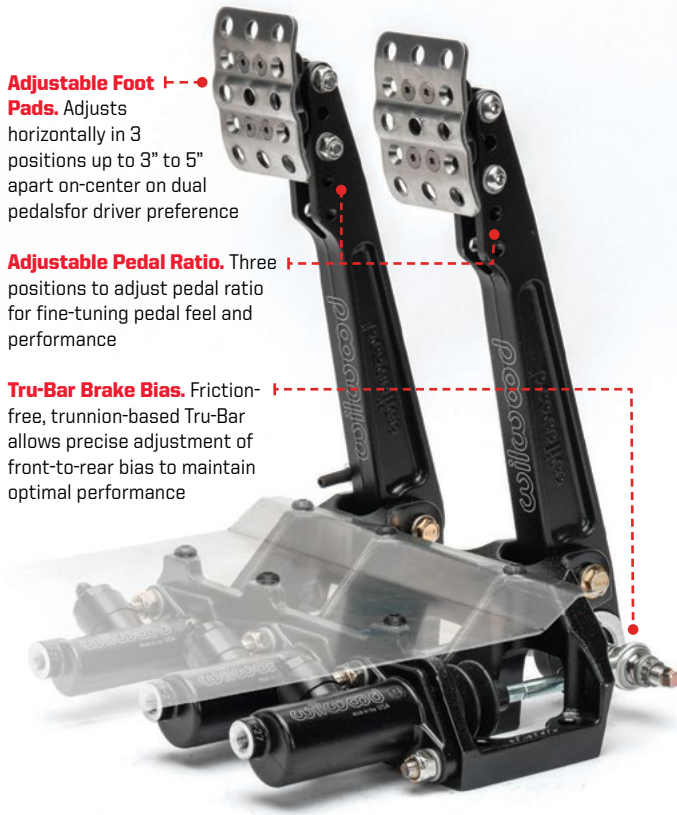

**Adjustable Foot Pads.** Adjusts horizontally in 3 positions up to 3" to 5" apart on-center on dual pedals for driver preference

**Adjustable Pedal Ratio.** Three positions to adjust pedal ratio for fine-tuning pedal feel and performance

**Tru-Bar Brake Bias.** Friction-free, trunnion-based Tru-Bar allows precise adjustment of front-to-rear bias to maintain optimal performance

### REVERSE FLOOR MOUNT **TRIPLE MASTER CYLINDER TRU-BAR ADJUSTABLE RATIO** PEDALS

## **XRZ** SPLINED HUB KITS **ROTOR ADAPTER & SPLINE SAVER**

- First **Lug-Drive/Hub** combination of its kind where rotor mounts to plate without bolts
- Smaller OD to ID rotor plates are wider providing strength, stiffness, and longevity
- Simplified rotor and rotor plate changes without removing the axle spline saver

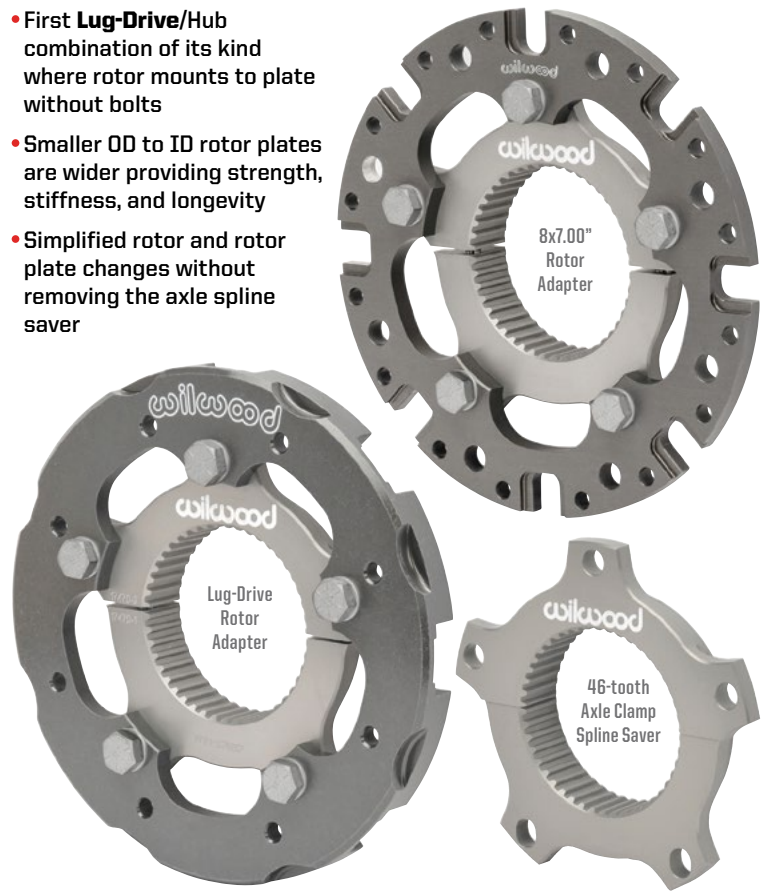

| BRAKE KITS | CALIPERS | ROTORS | MASTER CYLINDERS | PEDALS | PRESSURE VALVES | HATS | BRAKE FLUID |  
| BRAKE PADS | HUBS | PROSPINDLES | BRAKE LINES | FLEXLINES | PARKING BRAKES | HARDWARE |



LEARN MORE  
@ [wilwood.com](http://wilwood.com)  
805.388.1188



# **ERACING** wilwood

ESTABLISHED 1977

## BR MOTORSPORTS/IGNITIONEERING

brpromag.com | 559-739-1515

**BR BLACK MAGIC PRO MAG 44**

- Most powerful magneto in company's lineup
- Proprietary rare earth magnets
- Hand-wound induction coil
- BR's Blue Print technology

**BR BLACK MAGIC PRO MAG 20**

- Same magneto as the Pro Mag 44 with the exception of the induction coil
- Allows the 20 AMP to be used with a MSD 8106 spark box instead of a separate control box and coil system

**BR BLACK MAGIC 12LT**

- Blue Printed, which means extensive CNC machining and hours of calibration and special proprietary wiring including an external ground loom with water-tight connector as well as assembly procedures using the company's all new billet zero tolerance set-up fixtures

**BR BLACK MAGIC LOW PRO 12LT**

- Will allow you to lower your air filter system down a full 2 inches
- Increased horsepower because you can get more air into your air filter and also run shorter stacks
- Proven winner
- Has all the same great features as all the other BR Black Magic magnetos

# WORLD'S **FIRST**

## **ROBINS RUBi-Combo 1.10**

### **Cylinder Block Plato-Boring & Surfacing**

**PLATO BORING**

**RUBi  SURF**

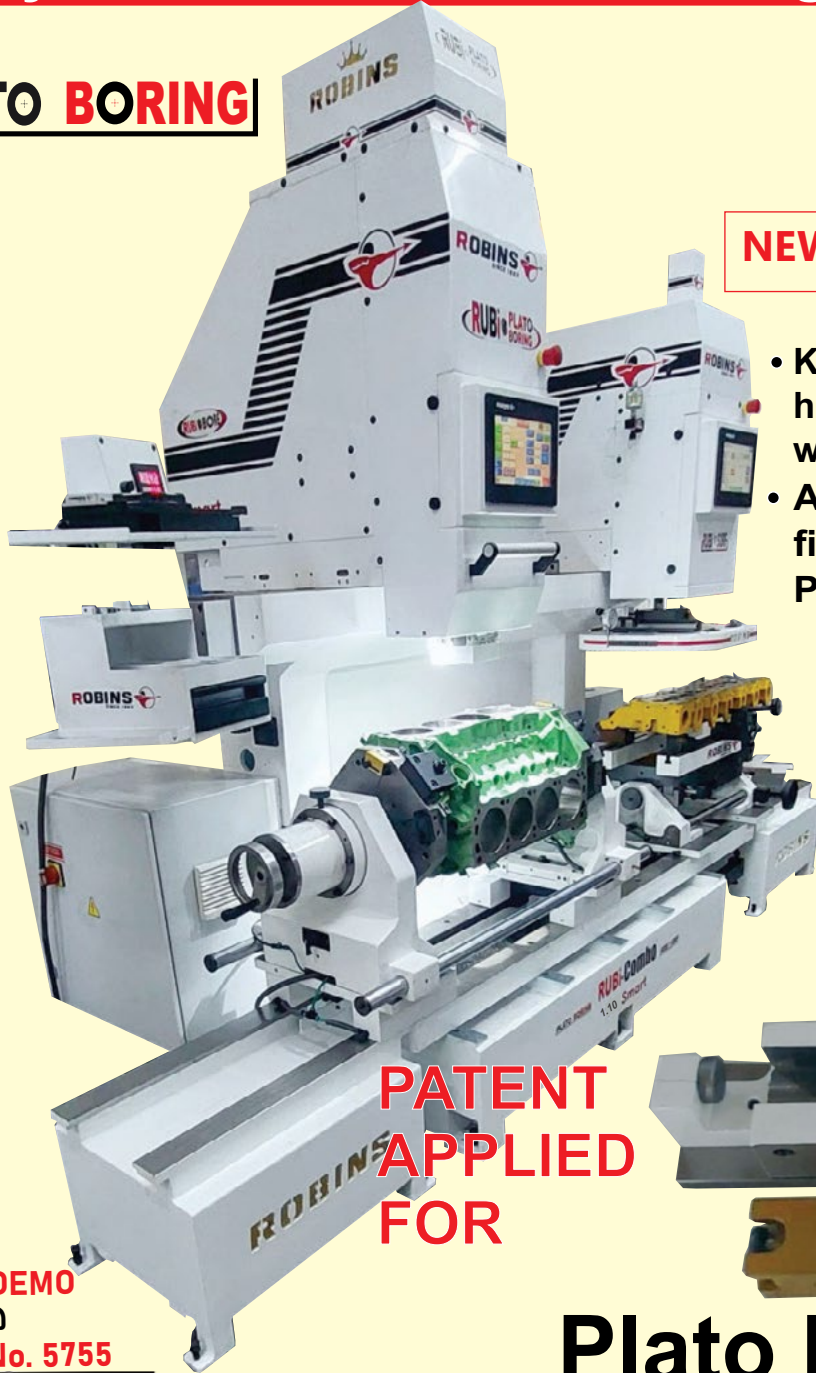

**NEW BLOCK BORING CONCEPT**  
US PATENT PENDING

- Keep V-Block, In-line & cylinder head tilt fixtures on the machine while boring or surfacing.
- Achieve rough honing surface finish & bore geometry in Plato-boring cycle.

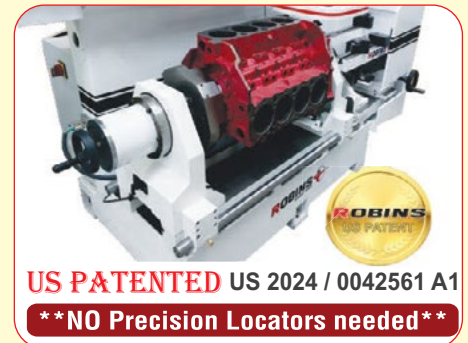

**PATENT  
APPLIED  
FOR**



## **Plato boring tools**

**LIVE DEMO**

@  
**Booth No. 5755**

**PRISHOW**

DECEMBER 12-14, 2024 INDIANAPOLIS, U.S.A.

**ROBINS** 

41 *Years of Excellence*  
[/robinsmachines.com](https://www.robinsmachines.com)  
[youtube.robinsmachines.com](https://www.youtube.com/robinsmachines.com)  
[rc@RobinsMachines.com](mailto:rc@RobinsMachines.com) | [www.RobinsMachines.com](http://www.RobinsMachines.com)

**Eastern U.S.A**



**Western U.S.A**

**MEC CNC**

**Anthony Usher** (949) 800-7176  
[anthony@meccnc.com](mailto:anthony@meccnc.com) | [www.meccnc.com](http://www.meccnc.com)

**Hopper HOPPER EQUIPMENT**

**Jeff Murchison** (909) 226-9922  
[Jeff@HopperShop.com](mailto:Jeff@HopperShop.com) | [www.HopperShop.com](http://www.HopperShop.com)

**Canadian customers**   
please contact.

**ADF DIESEL**

185 Paul-Gauguin, Candiac, Quebec,  
 Canada, J5R 0G7  
[marc.fontaine@adfdiesel.com](mailto:marc.fontaine@adfdiesel.com)  
 1-800-854-1275 ext. 7101

**ROBINS... A NEW TECHNOLOGY PREMIUM BRAND**

# BTR BRIAN TOOLEY RACING

briantooleracing.com | 888-959-8865



## BTR CAMSHAFTS

- Brian Tooley Racing grinds quality camshafts for many popular late model engines including LS, LT, Lvx (V6 LT), Gen 3 Hemi, Ford Godzilla and more
- Unique cam cores for superior heat-treatment, Landis grinders, REM micro-finishing, and test all the company's lobe designs on the dyno and the Spintron for peak performance



## BTR VALVE COVERS

- BTR valve covers for the LS engine are made in the USA. Castings are machined by BTR in Kentucky and are powder coated for a long, durable service life
- Covers feature great rocker clearance, internal baffling, and AN ports in all four corners. Couple with ICT P/N 551326 to fit LT engines
- Available in multiple colors, logo options, and with or without space saving coil mounts



## BTR VALVETRAIN COMPONENTS

- Valve springs are what launched BTR into business. BTR offers beehive, ovate, and dual spring options for many late model engines
- Offers superior valve springs, locks, in-house made steel and titanium retainers, shims, seals, trunnion upgrades, rocker arms, shaft mount kits, pushrods, US-made Delphi LS7 lifters, and more



## BTR INTAKE MANIFOLDS

- The BTR Equalizer intake for cathedral and square port LS was BTR's first intake featuring a space-saving underhung plenum, short runners for very high rpm or boosted setups, and a removable plenum lid for porting and direct port runner access
- The Trinity lineup for LS, LT, Godzilla, and Gen 3 Hemi platforms feature a three-piece design with interchangeable length and optional dual injector runners for tuning and upgrades

- Core Drilling
- Reaming
- Automatic Guide Honing  
With Cross Hatch Finish

# New Inventions New Technology

See us @ Booth No. 5755



## AUTOMATIC VALVE GUIDE HONING & MACHINING SYSTEM

# WORLD'S FIRST



- Automatic Honing Cycle
- Automatic Ream & Hone cycle
- Automatic Cross Hatch & Plateau

**Automatic Guide Honing with cross hatch & plateau honing features:**



- To improve surface finish in guide bore.
- Less wear with reduced friction.
- Better Lubrication .
- Better sealing - more power for improved engine performance.
- Tighter clearance - near zero - concen.

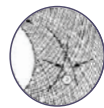

## AUTOMATIC VALVE GUIDE MACHINING SYSTEM (For Engine Builders)

### Accurate to 0.0001" (0.002 mm) Automatically!

**ROBINS**

41 Years of Excellence

[f](#)
[i](#)
[t](#)
[v](#)
[t](#)
[i](#)
[n](#)
[/robinsmachines.com](#)  
[youtube.robinsmachines.com](#)  
[rc@RobinsMachines.com](mailto:rc@RobinsMachines.com) | [www.RobinsMachines.com](http://www.RobinsMachines.com)

**Eastern U.S.A**

**MEC CNC**

Anthony Usher (949) 800-7176  
[anthony@meccnc.com](mailto:anthony@meccnc.com) | [www.meccnc.com](http://www.meccnc.com)

**Western U.S.A**

**Hopper HOPPER EQUIPMENT**

Jeff Murchison (909) 226-9922  
[Jeff@HopperShop.com](mailto:Jeff@HopperShop.com) | [www.HopperShop.com](http://www.HopperShop.com)

**Canadian customers please contact:**

**ADF DIESEL**

185 Paul-Gauguin, Candiac, Quebec, Canada, J5R 0G7  
[marc.fontaine@adf diesel.com](mailto:marc.fontaine@adf diesel.com)  
 1-800-854-1275 ext. 7101

ROBINS... A NEW TECHNOLOGY PREMIUM BRAND

## CP-CARRILLO

cp-carrillo.com | 949-567-9000



### PISTON AND ROD KITS FOR TOYOTA G16E-GTS ENGINE

- Pistons and rods, now available for the highest factory output three-cylinder engine. Rated for 900 hp drag race, or 750 hp road/rally race. Available in standard and 4-mm long rod piston and rod combos
- This unique long rod combo offers 50 gram piston weight savings, improving overall reciprocating mass, and rod ratio. This in turn helps provide longer bearing life, reduced piston skirt wear by reducing side loads, and help the engine rev quicker to increase top end HP
- Piston #SC7475 Rod #SCR14809



### PISTONS AND RODS FOR MERCEDES V8 ENGINES

- Designed for M176, M177, and M178 engine codes
- Using CP-Carrillo's strong "T" forging process for enhanced durability
- Includes .200-inch wall pins and upgraded PVD rings for superior performance: Steel PVD 1.2-mm top ring, Ductile Napier 1.2-mm 2nd ring, and Gas Nitride Steel 2.0-mm oil ring standard 3.2677-inch bore and 10.5:1 compression ratio
- Piston #SC7710 Rod #SCR14954



### 4 CYL. HONDA K24 ALUMINUM RODS

- Redesigned and engineered for extreme-horsepower applications and crafted for those who demand the absolute best
- 5.974-inch center to center, 0.010-inch shorter than stock, 7/16-inch bolts, roller burnished pin bores, floating bolt washers, and can be matched up with SC80461 Heavy Duty 10.5:1 CP Pistons (1.100-inch boss span)
- Piston #SC80461 Rod #SCR14934



### GODZILLA FORD 7.3L V8 PISTONS

- Rated for 1,500 hp and available in two bore sizes: 4.225-inch +.005-inch and 4.250-inch +.030-inch; Piston #BBFR6550-005 Rod #CR14791
- Includes .043-inch, .043-inch, 3.0-mm heavy-duty steel ring pack to withstand the power and heat
- 10.5:1 compression ratio, 1.338-inch compression height, and .990-inch x .200-inch wall. Chromoly wrist pins are standard
- Lateral gas ported for improved ring seal under extreme conditions



**ROBINS**  
SINCE 1983  
*Signature* brand



**RUBi-Bore 1.10**  
Smart  
CYLINDER BORING MACHINES

NEW DESIGNS BY ROBINS US 7,726,919 B1 | US 17879818 | US 17892165 | US 2024 / 0042561 A1

★ High Speed    ★ High Production    ★ Traditional Micron Accuracy

**5 MODELS TO CHOOSE FROM**

From Single Cylinder block boring (45mm bore dia) upto large diesel cylinder blocks such as Caterpillar 3412.

**BORING CAPACITY**  
3.300" - 5.000"  
(83-130mm)



**US PATENTED**

**PRISHOW**  
DECEMBER 12-14, 2024 INDIANAPOLIS, U.S.A.  
Booth No. 5755



**PlatoBore finish**



After years of research and trials, Robins proudly offers:

**New Revolutionary Concept In Cylinder Block Boring**

- After rough and fine boring cycles Rubi-Plato cycle produces Rvk, Rk, Rz Rpk, Ra parameters very close to finish honing cycle.
- Rubi-Plato boring eliminates any torn crystals/ metal tear & folded cast iron material left in bore cavities after finish boring cycle.
- Reduces final honing cycle time.
- Eliminates problems related to honing accuracies.
- Eliminates possible metal foldment caused by diamond honing process.
- After Plato boring, light honing followed by Cross-hatch and plateau cycle completes desired cylinder wall finish.
- Provides consistent Rvk , Rk and Rpk values.
  - Touch Button Automated
  - Simply float Spindle Head above "cylinder bore"
  - Press auto cycle & walk-away !

**ROBINS**

41 Years of Excellence  
[f](https://www.facebook.com/robinsmachines) [i](https://www.instagram.com/robinsmachines) [y](https://www.youtube.com/robinsmachines) [in](https://www.linkedin.com/robinsmachines) /robinsmachines.com  
 youtube.robinsmachines.com  
 rc@RobinsMachines.com | www.RobinsMachines.com

**Eastern U.S.A**

**MEC CNC**

Anthony Usher (949) 800-7176  
 anthony@meccnc.com | www.meccnc.com



**Western U.S.A**

**Hopper HOPPER EQUIPMENT**

Jeff Murchison (909) 226-9922  
 Jeff@HopperShop.com | www.HopperShop.com

**Canadian customers**  
 please contact:

**ADF DIESEL**  
 185 Paul-Gauguin ,Candiac ,Quebec,  
 Canada, J5R 0G7  
 marc.fontaine@adfdiesel.com  
 1-800-854-1275 ext. 7101

**ROBINS... A NEW TECHNOLOGY PREMIUM BRAND**

# DELTA PAG

deltapag.com | 212-203-2912



## BRUSHLESS FAN KITS

- More airflow—up to 4,100 CFM. Thinner—only 2.70 inches
- Soft-Start with variable speed for peak efficiency
- Unique designed small brushless motor packs a punch
- 12", 14", 16" and 18" sizes
- Digital controls and accessories included in the kit



## BRUSHLESS WATER PUMP

- 60 gallons per minute (227 liters per minute)
- Variable speed acts like a virtual thermostat, can remove mech. thermostat
- Brushless lasts over 50,000 hours
- Single 1.75" inlet and dual 1" outlets for max flow
- Will work with your ECU or Delta PAG's digital controller



## MONO-CORE ALUMINUM RADIATOR

- Newly designed aluminum cores use single extra-wide tubes vs. multiple smaller tubes
- Unique Mono-Core design increases air velocity effectively increasing heat dissipation
- The Mono-Core is also thinner than conventional radiators allowing for tight fit
- Mono-Core cools better than four row



## TRANS/ENGINE OIL COOLER

- Alloy Flat Tube w/Turbulators has high heat dissipation rate
- High flow rate with lowest pressure drop, supports high viscosity oils. Up to 250 PSI
- -10AN ORB inlet/outlet
- Two 1/8 NPT bungs for sensors or air bleeding
- Two different sizes to choose from: 165,000BTU/h or 240,000 BTU/h

**NEW**  
**Seat & Guide**  
**EZ matic**

**WELCOME TO ROBINS NEW SEAT & GUIDE ERA**

Next Generation **AUTOMATIC** Seat & Guide Machine

**RUBi SG 6.1 EZmatic**

**Cut by Wire**  
 Manual- Auto- Manual



**As easy as 1-2-3**

1. LOWER PILOT INTO VALVE GUIDE
2. **PRESS AUTO CYCLE**
3. EZ Matic COMPLETES SEAT CUTTING AUTOMATICALLY



**SCAN TO WATCH**

Introducing  
**RUBi-hard** <sup>PLUS</sup>  
 Get Double the Life!  
 Premium 3-angle cutting inserts:  
 Suitable for:
 

- Powder Metal and hardened Valve Seats 60 HRC & above
- Over 400 multi angle profiles to choose from

**NEW**  
  
**GOLD SERIES**  
 PRE-SET EXACT SEAT DIA ON  
 ROBINS ADJUSTABLE DUAL-MULTI-ANGLE  
 SETTING FIXTURE

**RUBi SURF**

**CYLINDER HEAD & BLOCK SURFACING MACHINES**



Surface finish down to **0.2 μm Ra**  
**Best in the industry**



**PRISHOW**  
 Booth No. 5755

**ROBINS**  
 41 Years of Excellence  
 @ / robinsmachines.com  
 youtube.robinsmachines.com  
 rc@RobinsMachines.com | www.RobinsMachines.com

**Eastern U.S.A**  
**MEC CNC**  
 Anthony Usher (949) 800-7176  
 anthony@meccnc.com | www.meccnc.com

**Western U.S.A**  
**Hopper HOPPER EQUIPMENT**  
 Jeff Murchison (909) 226-9922  
 Jeff@HopperShop.com | www.HopperShop.com

**NEW**  
**Canadian customers**  
 please contact:  
**ADF DIESEL**  
 185 Paul-Gauguin, Candiac, Quebec,  
 Canada, JSR 0G7  
 marc.fontaine@adfdiesel.com  
 1-800-854-1275 ext. 7101

**ROBINS... A NEW TECHNOLOGY PREMIUM BRAND**

# E3 IGNITION PRODUCTS

e3sparkplugs.com | 904-280-0339



## E3 RACE SPARK PLUGS

- Introducing E3 Spark Plugs' newest additions to its racing spark plug line
- Available in late 4th quarter 2024
- Cutback ground electrode built for high-compression applications
- Faster flame growth



## E3 RACE SPARK PLUGS

- Part Numbers:
- E3.90R-10, E3.90R-9, E3.90R-8
- E3.95R-8
- E3.96R-9
- E3.99R-8



## E3 SLEEVED RACE WIRE SETS

- E3.1503 E3 DiamondFIRE Sleeved Racing Spark Plug Wire Set for small block Chevy (SBC)-under headers
- E3.1505 E3 DiamondFIRE Sleeved Racing Spark Plug Wire Set for big block Chevy (BBC)-over valve covers
- E3.1507 E3 DiamondFIRE Sleeved Racing Spark Plug Wire Set for big block Chevy (BBC)-under headers
- E3.1509 E3 DiamondFIRE Sleeved Racing Spark Plug Wire Set for GM LSx



## E3 RACE/PERFORMANCE IGNITION COILS

- E3.602 Chevrolet-GM (2005-Current) Ultra-High Output LSx Ignition Coil
- E3.614 Chrysler (2006-Current) Ultra-High Output HEMI Ignition Coil
- E3.619 Ford (2011-Current) Ultra-High Output Coyote Ignition Coil
- E3.624 1997-2013 Two Valve Ford Ignition Coil

- CYLINDER BORING
- SURFACING
- SEAT & GUIDE
- GUIDE HONING
- VALVE REFACING

## SG12 Smart Series Seat & Guide

**HEAVY DUTY**  
Smart

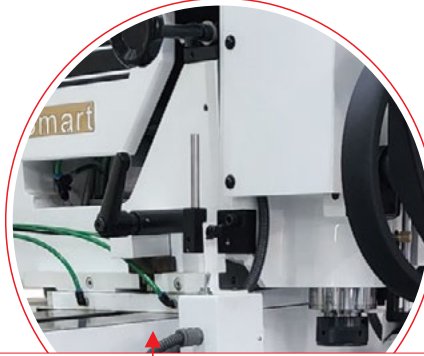

**ROBINS** Dual Centering System

Smart series machines include additional centering / work head float system that precisely centers small diameter pilots in valve guides, ensuring near zero valve seat run-out.



## VR 10P Valve Refacing

**New Features**



- **Diamond & CBN Grinding wheels** offering Long Life & Less frequent wheel dressing.
- **Foot switch** added for hands-free chuck operation.
- **Large V-nest** for diesel valves.

\*Machines displayed may include optional accessories\*

**PRISHOW**  
DECEMBER 12-14, 2024 INDIANAPOLIS, U.S.A.

**Booth No. 5755**

**ROBINS** 

41 Years of Excellence

[/robinsmachines.com](https://www.robinsmachines.com)  
[youtube.robinsmachines.com](https://www.youtube.com/robinsmachines.com)  
[rc@RobinsMachines.com](mailto:rc@RobinsMachines.com) | [www.RobinsMachines.com](http://www.RobinsMachines.com)

**Eastern U.S.A.** 

**MEC CNC**

Anthony Usher (949) 800-7176  
[anthony@meccnc.com](mailto:anthony@meccnc.com) | [www.meccnc.com](http://www.meccnc.com)

**Western U.S.A.** 

**Hopper HOPPER EQUIPMENT**

Jeff Murchison (909) 226-9922  
[Jeff@HopperShop.com](mailto:Jeff@HopperShop.com) | [www.HopperShop.com](http://www.HopperShop.com)

**NEW**

**Canadian customers please contact:** 

**ADF DIESEL**  
185 Paul-Gauguin, Candiac, Quebec, Canada, J5R 0G7  
[marc.fontaine@adfdiesel.com](mailto:marc.fontaine@adfdiesel.com)  
1-800-854-1275 ext. 7101

**ROBINS... A NEW TECHNOLOGY PREMIUM BRAND**

# FITECH FUEL INJECTION

fitechefi.com | 951-340-2624

**FiTech**  
Fuel Injection



## NEMESIS, UNIVERSAL 4500 4BBL THROTTLE BODY, TMAP OR MAP

- TMAP or MAP sensor options
- Dual IAC motors
- Primary shaft TPS

- Improved throttle response—flows 1820 CFM
- Ready to run throttle body
- Compatible with wide range of applications
- Threaded IAT port for boosted applications
- Dual high flow IAC passages for large displacement engine/high duration camshaft applications for smooth idle stability



## ULTIMATE LS DRIVE BY WIRE

- All-in-one package with ECU, harness, throttle body, and electronic pedal, expertly engineered for seamless integration
- Boosts performance, reliability, drivability, and acceleration over cable-driven systems

- Available in 102 mm
- Preset and configurable drive modes
- OEM quality
- Improved drivability with higher performance larger throttle body
- Hassle free install—no need for throttle cable or linkage



## CARBON FIBER LS MANIFOLD

- Lightweight carbon fiber low-profile design
- Longer runners for balanced torque and horsepower

- Lower sound resonance
- LS1 applications and more to come
- Billet throttle body for robust, leak-free sealing
- Fully loaded LS kits and other variations available
- Made of real carbon fiber (not an overlay)



## NITRO-PORT SERIES: LS1 CAST MANIFOLD

- -8 AN fuel rails using -8 Orb fittings for high-flow capability
- Nitrous/water injection bungs

- Low-profile design
- Modular runner design
- Accepts 92-mm, 102-mm, and drive-by-wire throttle bodies
- Straight throttle body mounting
- Short runner
- Rear-mounted threaded vacuum/pressure ports
- Rear-mounted MAP sensor mounting



BOOTH 725

Part No. 77620



Part No. 7763

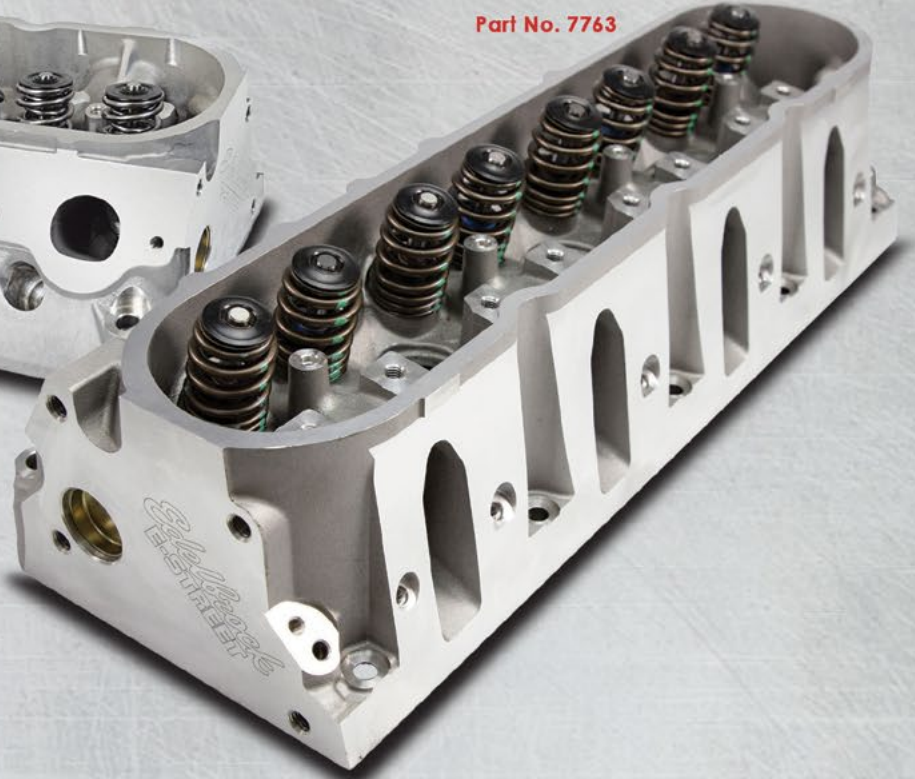

**E-STREET 15-DEGREE GM LS HEADS**

PART NO.	RUNNER	CHAMBER	SPARK PLUGS	VALVE SIZE		VALVE TRAIN	VALVE SPRINGS	MAX LIFT	RETAINERS	
				IN.	EX.				PART #	MATERIAL
7763	210cc	64cc	Angle	2.000"	1.550"	Hyd. Roller	Beehive	.570"	774-16	Chromoly Steel
7764	210cc	64cc	Angle	2.000"	1.550"	Hyd. Roller	Dual	.660"	713-16	Chromoly Steel
77618	260cc	69cc	Angle	2.165"	1.590"	Hyd. Roller	Dual	.660"	713-16	Chromoly Steel
77620	260cc	69cc	Angle	2.165"	1.590"	Hyd. Roller	Beehive	.570"	774-16	Chromoly Steel

**AVAILABLE AT NICKELS PERFORMANCE DISTRIBUTORS**

Nickels Performance Distributors has been serving Speed Shops, Engine Builders and Installers since the '70s in the Racing, Late Model Street, and American Muscle markets. What started out as Mark Nickels' one man operation has become a multiple location warehouse distributor that prioritizes customer experience over anything else.

Visit Nickels  
Booth 1501

**SAME DAY NATIONWIDE SHIPPING!**

**800.251.0331**



DECEMBER 12-14, 2024 | INDIANAPOLIS

# JMS PERFORMANCE

jmschip.com | 601-766-9424



## CD-1 SS RACE IGNITION KIT

- Plug and play—capacitive discharge racing ignition system CD1
- Approved racing ignition: Southern Super Series, CARS Super Late Model Tour, Spears Southwest Tour, American Canadian Tour, and all dirt late models
- PRI Show booth #2511



## TA2 RACE IGNITION

- Specifically designed for the Trans Am TA2 racing series
- A complete plug-and-play racing ignition system designed to be used on LS-based TA2 racing engines
- Fully encapsulated device preprogrammed with approved TA2 ignition timing advance tables



## FUEL MAX

- Fuel pump voltage booster featuring exclusive digital technology that provides up to an 85% increase in fuel
- Plug-and-play installation connects directly to your fuel pump driver module and activates via the pedal position sensor, minimizing install time
- User-adjustable voltage ramp-in/out rate allows elimination of fuel pressure spikes



## PEDAL MAX

- Designed for modern vehicles equipped with electronic throttle control systems
- Improved throttle response and acceleration, reduced lag in turbo applications, leading to more power and torque
- Easy to install inline between your vehicle's pedal position sensor and vehicle harness, utilizing OEM connectors with a control dial making performance adjustable on-the-fly





BOOTH 725

## LST™ (Low Stock Technology) Blower Cams

- ▣ Features Low Shock Technology (LST™) cam lobe profiles for increased horsepower and improved stability at higher RPM
- ▣ Spintron® and dyno tested to ensure maximum power, boost response and reliability
- ▣ Kits are available as well: Contain all components for a complete valve train upgrade in supercharged GM LS engines



Perfect choice for upgraded GM LS engines with larger displacement or larger blower applications that include more serious additional modifications for higher RPM and more power.

**CALL NICKELS TODAY FOR MORE INFO!**

**800.251.0331**

Part No. 54-335-11

### LST™ (Low Stock Technology) Blower Cams

PART NO.	APPLICATIONS	RPM RANGE	DURATION				VALVE LIFT		LOBE SEPARATION
			ADVERTISED		@ .050"		W/ 1.7 ROCKERS		
			IN.	EX.	IN.	EX.	IN.	EX.	
54-335-11	HYDRAULIC ROLLER – Excellent performance with smaller engines or any 5.3L mildly modified blower engine.	2000-7200	283	294	225	239	0.612	0.612	112
54-337-11	HYDRAULIC ROLLER – Perfect choice for upgraded GM LS engines with larger displacement or larger blower applications that include more serious additional modifications for higher RPM and more power.	2300-7400	291	302	233	247	0.612	0.614	115



Part No. 146106

## LSXHR 103mm Intake Manifold for LS3

The LSXHR, 103mm Intake Manifold for LS3 Rectangular Port Applications is the industry's first polymer tunnel ram-style intake manifold and is ideal for generating maximum power in boosted and naturally aspirated engines.

- ▣ Polymer construction is lightweight and high strength to eliminate power-robbing heat soak commonly found in aluminum intake manifolds
- ▣ Average 30 HP gain between 5,000 and 7,500 RPM over competitors
- ▣ Rated for up to 45psi of continuous pressure
- ▣ 103mm Throttle body opening can be ported to 105mm



ALSO AVAILABLE FOR LS1/LS6 & LS7 APPLICATIONS!

Visit Nickels Booth 1501



**VISIT NICKELSESTORE.COM TO PURCHASE!**



**PRI SHOW**  
DECEMBER 12-14, 2024 | INDIANAPOLIS

# KELFORD CAMS

kelfordcams.com | +64 3 929 0725

**KELFORD CAMS**   
POWER UNLEASHED



## DLC COATED CAM BUCKETS

- Choose Kelford Cams DLC Coated Cam Buckets for the Toyota, Nissan, Ford, Subaru, and more
- Reinforced skirt, larger internal fillet, and DLC coated follower surface results in decreased friction, improved torque, and lower oil temperatures
- Exceptional performance and reliability.



## BMW S58 CAMSHAFTS

- BMW S58 is the high performance version of the legendary B58 3.0L inline six, well known for delivering huge power gains with fairly basic modifications
- Kelford Cams produces premium camshafts for Stage 1, 2, and 3 S58 engine builds: Stage 1: 600–800 hp / Stage 2: 800–1400 hp / Stage 3: 1400+hp



## HONDA K SERIES CAMSHAFTS

- Kelford Cams produces five varieties of premium camshafts for the Honda K Series engine
- 179-A suits 2.0L builds for many applications. 179-B2 - K20a-24 for ultimate racing applications. 129-C suits professionally built, large displacement K series race engines. 179-T1 for 600–1000 hp, using 62–68-mm turbos. 179-T2 for 1400+hp engines using 75–86 turbos



## AUDI DAZA CAMSHAFTS

- One of Kelford Cams' latest releases. They produce three varieties of premium camshafts for the Audi DAZA engine
- 273-EZ drop-in cams, 400 hp–800 hp using high-flow turbos and turbos up to 64 mm in size. 273-A up to 1200 hp, for cars using 64-mm–72-mm turbos. 273-B 1400+ hp using 75-mm–83-mm turbos



BOOTH 4409

Moroso Performance Products is one of the worlds most respected suppliers of automotive equipment for racing and street performance applications. Moroso manufactures over 4000 products, from oil pans and oiling systems, to ignition wire, ignition components, valve covers, fuel system equipment, air cleaners, hard-core racing tools, chassis and suspension equipment and numerous other performance parts.

# BIG BLOCK CHEVY FROM MOROSO



**Part No. 20485**  
BBC Mark IV Oil Pan, 8" Deep,  
Double Power Kick Outs

**Part No. 68469**  
BBC Billet Aluminum 3" Tall Valve Covers

**Part No. 22163**  
BBC High-Volume  
Billet Oil Pump

**Part No. 93156**  
BBC Mark IV Oil Pan Gasket  
For "Race Pattern"

**Part No. 63547**  
BBC Billet Aluminum  
Electric Water Pump

**Part No. 60008**  
BBC Crank Trigger Kit,  
4.75" Registers

**Part No. 73820**  
Ultra 40 Ignition Wire Set  
BBC HEI, 90° Boots

## AVAILABLE AT NICKELS PERFORMANCE DISTRIBUTORS

Nickels Performance Distributors has been serving Speed Shops, Engine Builders and Installers since the '70s in the Racing, Late Model Street, and American Muscle markets. What started out as Mark Nickels' one man operation has become a multiple location warehouse distributor that prioritizes customer experience over anything else.

Visit Nickels  
Booth 1501

**SAME DAY NATIONWIDE SHIPPING!**

 **800.251.0331**



# MELLING PERFORMANCE

melling.com | 517-787-8172



## DUAL VALVE SPRING

- P/N 461901-16
- O.D. 1.540"
- I.D. .760"
- Installed load 145 @ 1.900
- Open load 465 @ 1.250
- Solid +height 1.190"
- Rate 491



## BILLET ALUMINUM OIL GALLEY PLUG FOR GM LS / LT

- P/N MOGP-100HP for Gen 3/4 GM LS / LT
- P/N MOGP-200HP for Gen 5 GM LS / LT
- Visit [melling.com](http://melling.com) to find more parts for your performance engine build



## NEW CAMSHAFTS FOR FORD GODZILLA 7.3L

- P/N 24116 – Intake valve lift 0.596"; Exhaust valve lift 0.603"
- P/N 24216 – Intake valve lift 0.596"; Exhaust valve lift 0.577"
- P/N 24316 – Intake valve lift 0.669"; Exhaust valve lift 0.669"
- Billet steel cam core



## OIL PUMP PICKUP TUBE BRACKET FOR GM LS

- P/N M29500
- Billet aluminum construction
- Utilizes unused screen mounting hole for additional clamping force



# Our formation advances yours.

When you enlist in the U.S. Army, you instantly become a part of something much bigger than yourself. As a member of this diverse group of world changers and history makers, you'll strive toward a common good — multiplying your strengths, maximizing your impact, and creating lifelong friends in the process. If that's a mission you can relate to, the call is simple.



**U.S. ARMY**

**BE ALL YOU CAN BE.**

[GOARMY.COM](https://www.goarmy.com) →

©2023. PAID FOR BY THE UNITED STATES ARMY. ALL RIGHTS RESERVED.

# MELLING PERFORMANCE

melling.com | 517-787-8172



## CYLINDER HEAD VALVE KITS FOR GM LS

- P/N MVK101; MVK102; MVK103; MVK104
- Installed load: 151 @ 1.800"
- Open load: 417 @ 1.150"

- Coil bind: 1.080"
- Intake head diameter: 2.020"
- Exhaust head diameter: 1.600"
- Kits include Viton valve-stem seals, valve locks, chromoly steel spring



## NEW VALVE SPRING PACK

- P/N 29555
- Relief pressure: 55 lbs.
- Use with 10294, 10295, 10296 oil pumps



## BILLET STEEL GEROTOR FOR FORD 5.0L COYOTE OIL PUMPS

- P/N 11396
- Made of chromoly steel
- Increased tensile strength and toughness
- Direct replacement for OEM powdered metal gerotor
- 2011–2023 Mustang, 2015–2017 Ford F150



## PERFORMANCE OIL PUMP FOR DODGE, CHRYSLER, JEEP 5.7L & 6.4L

- P/N 10452-BR
- Exclusive billet chromoly steel rotor set
- High pressure spring installed (+20 psi over

Hemi 5.7L, +10 psi over 6.4L)

- Features hard-coat anodized aluminum housing and phosphate coated cast iron cover for improved performance and durability
- Includes oil pump screen mounting O-ring and additional standard Hemi 6.4L pressure spring

# UNLOCK MAXIMUM POWER: CYLINDER HEADS

PRECISION-PORTED FOR ULTIMATE PERFORMANCE!



## 2001-2010 GM 6.6L DURAMAX CNC-PORTED CAST IRON CYLINDER HEADS-LB7/LLY/LBZ/LMM



50 States  
Emissions Legal  
E.O. D-701-38

Upgrade your Duramax with PPE's Ported Cast Iron Cylinder Heads. Unlike OEM aluminum heads that can cause blown head gaskets and warp under heat, PPE cast iron heads are engineered for durability and perfect thermal expansion with the cast-iron block. They offer elevated fatigue strength, and heat resistance, which prolongs the cylinder head lifespan significantly.

Made from high-strength alloyed gray iron, PPE heads resist cracking and heat fatigue. Our CNC porting process improves airflow for more horsepower, torque, and fuel efficiency, reducing engine stress and turbo lag. Whether you're replacing damaged heads or boosting performance, PPE's Cast Iron Cylinder Heads deliver lasting reliability and power.

**Applications:**

2001-2004 GM 6.6L Duramax  
- LB7

P/N: 110100111

**Applications:**

2004.5-2010 GM 6.6L Duramax  
- LLY/LBZ/LMM

P/N: 110100113



Innovations in performance.

SCAN NOW



FOR MORE PARTS



PACIFIC PERFORMANCE ENGINEERING

PPEpower.com | 725.238.2002

# MOLNAR TECHNOLOGIES

molnartechnologies.com | 616-940-4640



## EIGHT COUNTERWEIGHT LS BILLET 4340 CRANKSHAFT

- A true billet crankshaft with counterweights located to reduce bending and flexing in high-rpm engines



## CHEVY DURAMAX DIESEL 4340 BILLET H-BEAM CONNECTING RODS

- Designed for high strength and high quality at an affordable price



## FORD 7.3L GODZILLA CONNECTING RODS

- Available in both PWR ADR and PWR ADR Plus versions for high boost and/or sprayed applications



## PWR ADR PLUS CONNECTING RODS

- These rods are made for high boost and sprayed applications where maximum rod strength is needed
- Available in different lengths and configurations for small block and big block Chevy, Ford, and Chrysler applications





# NEW PRODUCTS *by*



## BP BR X 18™ **NEW**

With the introduction of the NEW BP BR X 18™, BRODIX® has once again set the standard in the big block Chevy compatible market. Inspired by Pro Stock technology, the BP BR X 18 far outshines all others in its class. This head features a NEW 18° valve angle, designed to produce the maximum amount of torque and horsepower, in a conventional package. The intake port is raised .900 and amazingly flows over 535 cfm with a 2.500 valve! The exhaust port flows over 340 cfm through only a 1.830 valve! This head also has an extremely efficient 93 cc combustion chamber that is nitrous friendly. This head requires pistons, valve covers, shaft rockers, and an intake manifold specifically designed for the BP BR X 18. As always, these NEW heads come standard with all of the fine qualities that only BRODIX has to offer.

**+1300 HP**

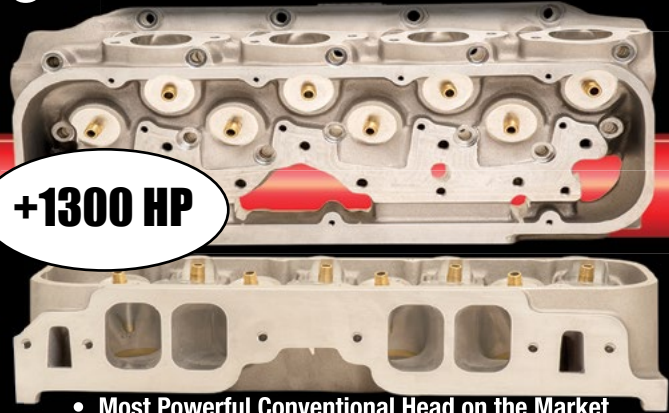

- Most Powerful Conventional Head on the Market
- 18° Valve Angle
- 93 cc Combustion Chambers
- Intake Port Flows Over 535 cfm
- Exhaust Port Flows Over 340 cfm
- 2.500 / 1.830 Valve Sizes
- 100% CNC Ported
- Toughest Castings in the Business

## 8B 2000 C™

- .400 Raised Cam Location
- Available up to 10.700 Deck Height
- May Be Bored up to 4.600
- Reinforced Lifter Valley
- Available With Roller Cam Bearings



## 8B 2200 C6™ **NEW**

- .600 Raised Cam Location
- Standard 4.840 Bore Spacing
- Available up to 11.625 Deck Height
- May Be Bored up to 4.600
- Reinforced Lifter Valley
- Available With Roller Cam Bearings
- Available With Half Filled Water Jacket



## 8B 2100 C6™ **NEW**

- .600 Raised Cam Location
- Standard 4.840 Bore Spacing
- Available up to 11.200 Deck Height
- May Be Bored up to 4.600
- Reinforced Lifter Valley
- Available With Roller Cam Bearings
- Available With Half Filled Water Jacket

## BM 2018 PC 18™ **NEW**

- Fits BRODIX BR X 18 Heads
- NEW 3D Printed Plenum Requires No Porting
- 4500 Series Top - Will Accept 2.500 Throttle Blades
- 9.800 Deck Height
- 5000 – 8500 rpm Range
- Also Available: BM 2028 PC 18™, BM 2100 PC 20™, BM 2110 PC 20™

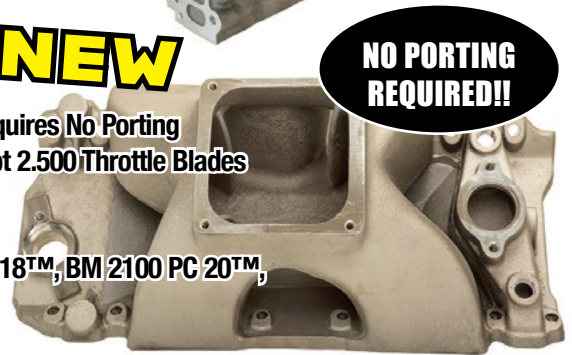

**NO PORTING REQUIRED!!**

## BRODIX® Titanium Intake and Exhaust Valves

- CrN (Chromium Nitride) Coating
- No Hardened Tips Installed (for Use With Lash Caps Only)
- Common Lengths and Sizes in Stock
- Available for Most BRODIX® Cylinder Head Part Numbers
- Also Available Through BRODIX® Dealers
- \$148.48 Each/Retail

**\$148.48**



**PROUDLY MADE IN THE USA!**

Sign up at [www.brodix.com/signup](http://www.brodix.com/signup) to hear the latest and greatest news from BRODIX®!

[www.brodix.com](http://www.brodix.com)



Visit [www.brodix.com/shop](http://www.brodix.com/shop) to see BRODIX® apparel!

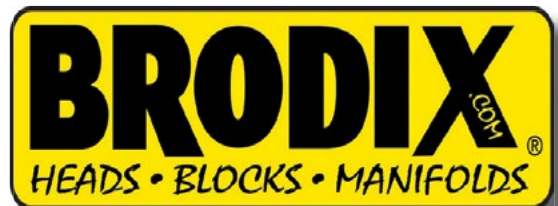

301 MAPLE AVE. P.O. BOX 1347 MENA, AR 71953  
(479) 394-1075 • FAX: (479) 394-1996

NOT LEGAL FOR SALE OR USE IN CALIFORNIA ON ANY POLLUTION CONTROLLED MOTOR VEHICLE

© Copyright 2024 Brodix, Inc.

# OPTITORQUE TECHNOLOGIES

optitorque.com | 315-924-3888

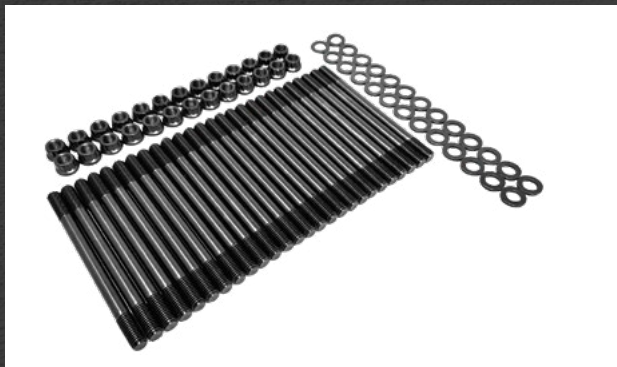

## PATRIOT SERIES FASTENERS

- Provides a performance upgrade over OEM torque-to-yield fasteners
- Available for popular domestic, import, and diesel stud and bolt applications for heads and mains, as well as exterior and accessory fasteners
- OptiTorque fasteners are manufactured in the USA from domestic materials



## H11 TOOL STEEL FASTENERS

- Providing solutions and strengths from 240 – 275 ksi
- Available for: custom fasteners, popular domestic, import, diesel, engine, and powertrain applications
- OptiTorque fasteners are manufactured in the USA from domestic materials



## TORQUEMASTER SERIES FASTENERS

- OptiTorque TorqueMaster is the go-to alloy for serious performance applications, offering the improved stretch area in its price class while increasing fatigue and clamping properties
- Available for popular domestic, import, and diesel stud and bolt applications for heads and mains
- Manufactured in the USA from domestic materials



## CUSTOM AGE FASTENERS

- OptiTorque Custom Age fasteners are for ultra-high-performance applications without compromise
- Features the company's proprietary processes and a corrosion-resistant tumbled finish
- Available for popular domestic, import, and diesel stud applications, including aftermarket blocks
- OptiTorque fasteners are manufactured in the USA from domestic materials



**BUILDING TRUST**



**FUELING PASSION**

Our state-of-the-art facility performs at the highest level to serve our dealers with trust and passion.

From the east to the west coast, and worldwide, Motor State proudly serves a variety of markets including Drag Racing, Engine Builder, Circle Track, Open Wheel, Modern Muscle, Circuit/Drift, Hot Rod, Early Muscle, Jeep, Truck, and Off-Road.

Become a Motor State Dealer. Visit our website and apply today.

[motorstate.com](http://motorstate.com) 800.772.2678

Dealer Application



# PETERSON FLUID SYSTEMS

petersonfluidsys.com | 800-926-7867



## R4 DRY SUMP OIL PUMP

- Lightweight design features aluminum rotors, shallow depth screw-in fittings, and profile
- Rear drive setup standard allows for direct mounting of all popular steering/fuel pumps
- Four-lobe rotor is patent pending, twisted design for superior vacuum
- Superior oil pressure at high oil temps
- Unique and versatile mounting system
- Customized for unique applications



## OIL TANKS

- Unique baffle system has been refined to provide the best deaeration performance
- Manufactured from spun aluminum and CNC-machined flanges and fitting for lightweight performance
- Custom configurations available



## REMOTE FILTER MOUNT W/ ENGINE OIL PRIMER

- 20 psi in as little as 10 seconds using a standard cordless drill
- Utilizes an R4 twisted-lobe rotor design for quick delivery
- AN port fittings and tube, firewall or tank mounting options available



## OIL & FUEL FILTERS

- Durable anodized billet body and end cap
- Wide variety of available accessory caps
- Pleated stainless steel or 10/20 micron filter elements
- Wide variety of available options for unique applications

# ACT

ADVANCED CLUTCH TECHNOLOGY®

**ACT GENERAL MOTORS SFI-APPROVED  
10.5" MOD-TWIN CLUTCH KIT FOR:**

**GM ZL1 LT1/LT4 | GM LSA  
GM LS1 / LS2 / LS3 / LS6 / LS7**



206 EAST AVE K4, LANCASTER CA 93535  
ADVANCEDCLUTCH.COM | 661-940-7555



## PROFORM PARTS

proformparts.com | 586-774-2500



### PROFORM RACE SERIES E85 CIRCLE TRACK CARBURETOR

- 650 CFM Race Series E85 carburetor circle track-specific design, hand-assembled in the USA
- Featuring aluminum fuel bowls with a reduced drop fuel ramp and wedge-shaped floats for superior fuel control
- High-flow main body with contoured Venturi, for improved airflow. Billet metering blocks with enhanced baffling reduce fuel slosh. Mechanical secondaries and billet throttle baseplate



### BRUSHLESS ULTRA-PERFORMANCE DUAL 12-INCH FAN KIT

- Higher CFMs in a thinner profile, perfect for 12-volt systems with no need for a controller
- Universal, lightweight, low-profile, and designed for easy installation, they prevent amp spikes with a soft start ramp-up and fit most cars and trucks
- Features a thin design, reinforced polypropylene blades, and includes a nylon tie mounting kit



### LIGHTNING-BOLT 100 AMP MINI-ALTERNATOR; 10SI MOUNT

- The Lightning-Bolt 100 AMP Mini-Alternator is 40% lighter than a 10SI, generating 80+ amps at idle and 100+ amps at top end
- Weighing just 7 lbs., it's perfect for both the drag strip and street, with a stylish aluminum housing
- Includes a one-wire hookup, V-belt pulley, and adapter for easy 10SI mount installation



### CHEVY SMALL BLOCK GEN I BLACK ELECTRIC WATER PUMP

- PROFORM's electric water pumps eliminate weight and impeller drag, pumping 35+ gallons per minute for maximum cooling at high rpm
- Made from durable, lightweight die-cast aluminum with a black powder-coated finish, perfect for both race and street applications
- Features a 12-volt motor, 6-amp draw, billet aluminum fitting, and includes gaskets and mounting hardware for Chevy small block V8s

# TUNE UP YOUR TOOL STORAGE

*PIT CARTS & TOOLBOXES*

*TRAILER & GARAGE CABINETS*

*ACCESSORIES*



**PRI** / BOOTH #1925  
EXHIBITOR / BOOTH #2025

[WWW.CTECHMANUFACTURING.COM](http://WWW.CTECHMANUFACTURING.COM)



# REMFLX

remflex.com | 866-641-SEAL



## PN 2008

- Remflex exhaust gasket set
- Fits GM LS engines with 1 7/8-inch round port
- Including 5.3L – 6.2L LS1, LS2, LS3, LS6 and L99
- Also 4.8L – 6.0L truck and Hummer
- Easy, drop-in installation
- Lowers exhaust gas temperatures

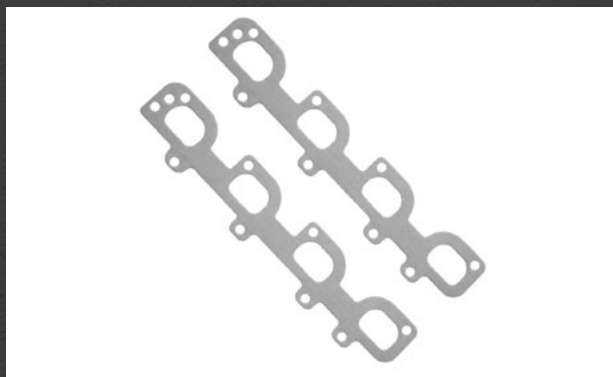

## PN 6022

- Remflex exhaust gasket set
- Mopar V8 Hemi 5.7L (2009 & up)
- 6.1L (2005–2010)
- 6.4L (2012–2016) with oval/D-shaped port measuring 1-15/16 x 1-3/8 inch



## PN 7009

- Remflex combination intake and exhaust for Toyota engines
- Fits L6 3.9L "F" (1969–1974)
- 4.2L "2F" (1975–1987)
- Stock-port Toyota Land Cruiser engine codes (F,2F)
- Heat riser and EGR gaskets included
- Six-piece set

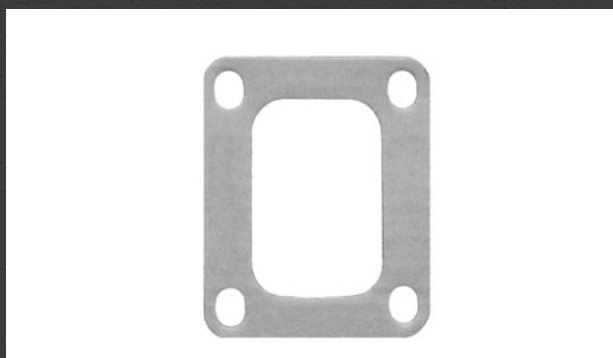

## PN 18-006

- Remflex Turbo HD inlet gasket
- Fits Garrett, Greddy T4 inlet
- Four-bolt, turbo inlet/up-pipe gasket with open plenum
- 3- x 2-inch square
- Four elongated bolt holes
- Bolt spacing 3.250-inch on long side, 2.750-inch short side





**THE LEADER IN INNOVATIVE  
SURFACE FINISHING SOLUTIONS**

## PIPE BELT FINISHER

- + Ideal for finishing on pipe and rounded surfaces.
- + Abrasive belt contacts 180° of workpiece simultaneously for fast and even finishes.
- + Features adjustable head assembly and side handle for optimum control and operator comfort.
- + Accepts coated abrasive and non-woven nylon belts in widths of 1/2" to 1-1/2" by 30" long.
- + For use on rounded surfaces from 3/8" to 6" in diameter.



**WE LISTEN. WE OBSERVE. WE INNOVATE.**

DYNABRADE, INC. | 8989 Sheridan Drive | Clarence, New York 14031 USA | 1.800.828.7333

 **DYNABRADE.COM**

**SBI**

sbintl.com | 615-248-6281



### SMALL BLOCK CHEVROLET PERFORMANCE INTAKE VALVE

- One-piece stainless-steel construction provides strength and corrosion resistance during high-temperature operations
- Swirl-polished and fully machined surfaces improve gas flow for optimal performance
- Hardened stem tip resists high-impact forces in performance valvetrain setups
- Chrome plated and undercut stem to reduce wear/galling while reducing weight and improving gas flow



### SMALL BLOCK CHEVROLET PERFORMANCE EXHAUST VALVE

- One-piece stainless-steel construction provides strength and corrosion resistance during high-temperature operations
- Swirl-polished and fully machined surfaces improve gas flow for optimal performance
- Hardened stem tip resists high-impact forces in performance valve train setups
- Chrome plated and undercut stem to reduce wear/galling while reducing weight and improving gas flow



### BIG BLOCK CHEVROLET PERFORMANCE INTAKE VALVE

- One-piece stainless-steel construction provides strength and corrosion resistance during high-temperature operations
- Swirl-polished and fully machined surfaces improve gas flow for optimal performance
- Hardened stem tip resists high-impact forces in performance valve train setups
- Chrome plated and undercut stem to reduce wear/galling while reducing weight and improving gas flow



### BIG BLOCK CHEVROLET PERFORMANCE EXHAUST VALVE

- One-piece stainless-steel construction provides strength and corrosion resistance during high-temperature operations
- Swirl-polished and fully machined surfaces improve gas flow for optimal performance
- Hardened stem tip resists high-impact forces in performance valve train setups
- Chrome plated and undercut stem to reduce wear/galling while reducing weight and improving gas flow

# DARTON SLEEVES™

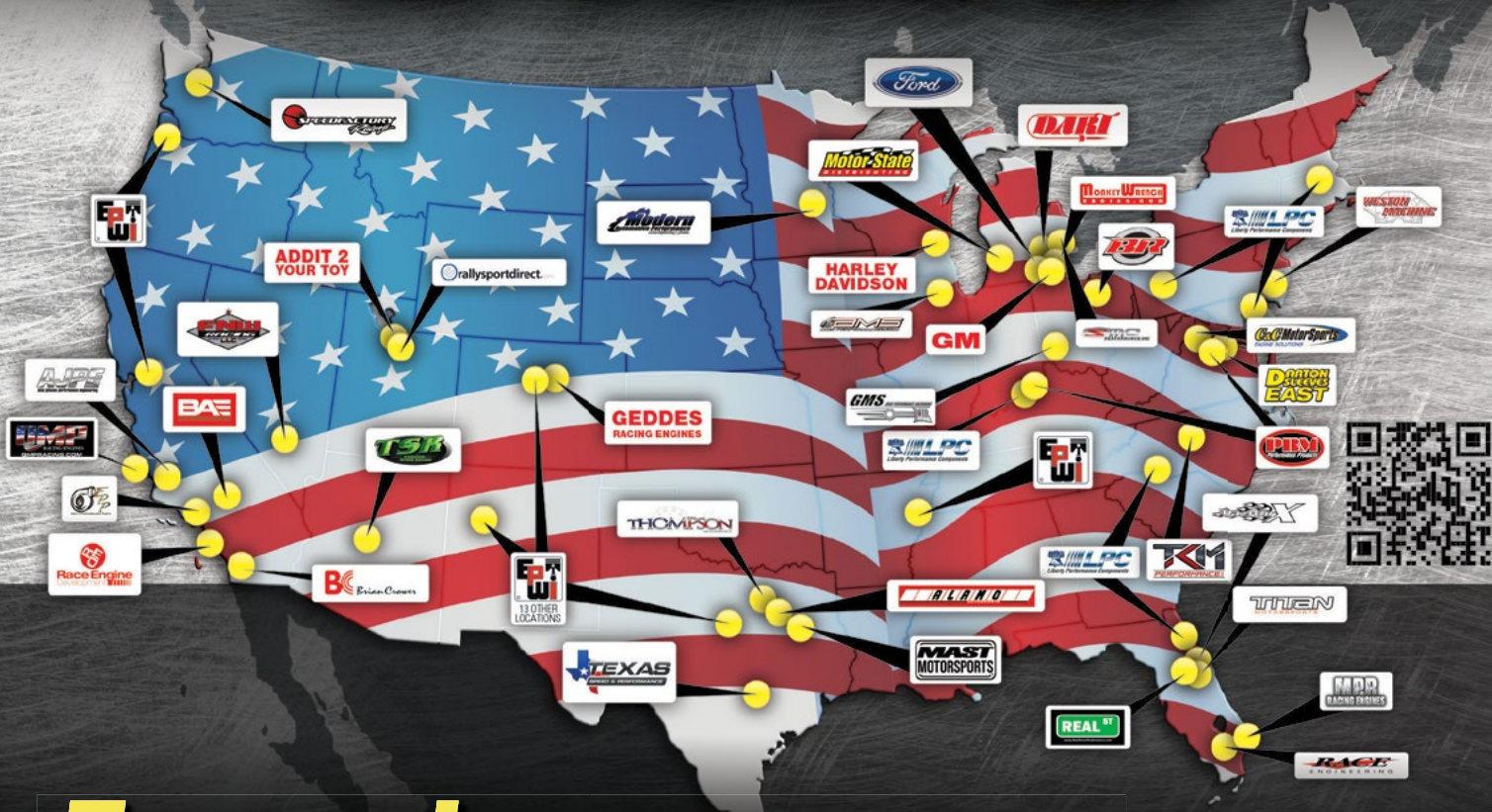

**Everywhere**  
our customers want us to be...  
and all over the world.

**Win With The Best** in all Categories  
of Product, Support & Quality

**46**  
years

OF PRODUCT PERFECTION

**DARTONSLEEVES.COM**

WEST: (800) 713-2786 or  
(760) 603-9895

EMAIL: sales@dartonsleeves.com

 @dartoninternational

  @dartonsleeves





### 1SPEC 1SPEC EVOLUTION SBC BLOCK

- Cast iron SBC block
- Standard or reverse cooling
- Deck heights 9.025 inches–9.325 inches
- 0.391-inch raised cam
- 4.400–4.500-inch bore center
- Wide oil pan rail
- Oil filter provision
- 55-mm roller or 60-mm Babbitt
- 350 or 400 main
- One- or two-piece rear main seal
- Short and mid-deck versions coming soon

Contact: 317-739-3189

[1spec.net](http://1spec.net)



### BILLET SPECIALTIES LT4 BILLET SUPERCHARGER LID PRECISION MACHINED FROM 6061-T6 ALUMINUM

- Available hard-coat black anodized or raw machine finishes
- Up to 8 RWHP increase
- 6061-T6 billet aluminum construction
- Raw machine or black hard-coat anodized finishes match the company's other accessories
- Polished ARP 12-point stainless fasteners included
- Uses the OE gasket for easy install and replacement
- Better air distribution resulting in even flow over the heat exchangers for consistent cooler temps
- Works with both Gen1 and Gen2 heat-exchanger bricks

Contact: 708-588-0505

[billetspecialties.com](http://billetspecialties.com)



### AERO EXHAUST AERO TURBINE XL

- Patented airfoil cone technology
- Integrated resonator
- High-grade stainless steel
- Mirror polished finish
- Aero Exhaust stamped logo
- Fully welded construction
- Increased power and torque

Contact: 801-301-0408

[aeroexhaust.com](http://aeroexhaust.com)



### BLACKBIRD PERFORMANCE SUPERCHARGER BELT TENSIONER FOR AFTERMARKET SYSTEMS (WHIPPLE) AND PRODUCTION HELLCAT/ TRACKHAWK/TRX WITH 10- OR 12-RIB PULLEY

- More usable range of motion for pulls well above 10,000 rpm
- Robust, higher capability with improved control and load carry
- Stout construction and stops
- Constant spring force and dampening
- Made in the USA

Contact: 309-360-9415

[blackbird-performance.com](http://blackbird-performance.com)



### BEHRENT'S PERFORMANCE WAREHOUSE

### BSC COMPONENTS TWIN- FLOW SPRINT CAR RADIATOR

- PN: BSC400-49938
- Elevate your sprint car's performance with BSC Components' Twin-flow Radiator
- Experience improved cooling efficiency and reliability in the extreme conditions of sprint car racing
- Dimensions: 17.5 inches tall, 20.5 inches wide
- Weight: 8.5 lbs. (empty)
- High-efficiency twin-flow design
- Top-fill convenience for easy refills
- Lightweight aluminum construction
- Don't compromise your performance—upgrade your radiator today!

Contact: 845-651-7389

[behrents.com](http://behrents.com)



### BLUEPRINT ENGINES LS COMPATIBLE "HIGH STRENGTH, PERFORMANCE" CRATE ENGINES

- 100% new Blueprint Engines LS high-strength iron block
- Improved water jacket design for improved cooling
- Extended 5.75-inch cylinder skirt for added piston stability at bottom dead center
- Thicker deck faces, making surfaces more rigid and ideal for forced induction applications
- Priority main oiling for optimum performance and protection
- Six-bolt main to increase strength and durability
- One-piece rear main seal
- Blueprint aluminum LS3 compatible rectangular port performance cylinder heads

Contact: 308-236-1010

[blueprintengines.com](http://blueprintengines.com)

# MAHLE Performance

Put only the best in your engine!



SCAN TO  
LEARN MORE

MAHLE parts outperform so you can too...

## Engine bearings

When choosing quality parts to go fast and go the distance, choose CLEVITE.

The best engine builders in the world know that with building race engines, even the best techniques and highest precision will not make up for inferior parts. That is why the cornerstone of every performance engine should be CLEVITE® engine bearings. After all, it's your reputation on the line – would you trust it to anything else?

## Piston rings

From the early days of producing cast iron rings, to modern day offering of the most advanced technology in coated steel rings, the St. Johns, Michigan plant continues to produce high quality piston rings after more than 75 years. Though materials and coating technology have changed greatly throughout the years, one thing remained the same – MAHLE piston rings are made in the USA, by highly skilled craftsman, using the highest quality materials.

## Gaskets

The latest technology combined with advanced materials, MAHLE performance gaskets provide unrivaled quality across the board.

The MAHLE Performance gasket line was built from the ground up, using the latest technology and most advanced materials to seal and protect engines designed to run harder, faster and push beyond the limits of conventional gaskets.

## Shop Equipment



Let the ShopPRO® lifting equipment from MAHLE Service Solutions safely do the heavy lifting to make working on your car easier.

Scan this QR code to view the entire ShopPRO line.



[mahle-aftermarket.com](http://mahle-aftermarket.com)



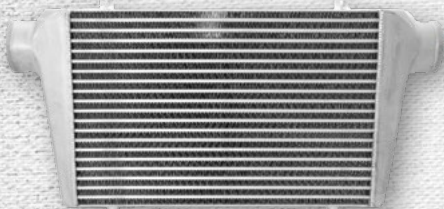

### BOOST PRODUCTS USA COMPETITION INTERCOOLER

- Boost Products USA's competition intercoolers provide you with a new generation cooling core
- Offered at the best possible price-to-performance ratio

Contact: 469-250-9589  
[boostproductsusa.com](http://boostproductsusa.com)



### BOROWSKI RACE ENGINES LS, LT AND BIG BLOCK PARTS, ASSEMBLIES AND COMPLETE ENGINES

- Inventory of parts and assemblies needed to produce Borowski's own complete engines
- Inventory-focused menu and all-CNC shop allow the company to offer short lead times and superior quality
- Quality parts brands and assemblies Borowski makes available to you are the same ones the company uses

Contact: 815-725-2727  
[borowskirace.com](http://borowskirace.com)



### BRASWELL CARBURETION CRATE CARBURETORS

- CT-350 (602)
- CT-400 (604)
- CT-525
- Gas/110; E-85; Ethanol; Methanol
- Dyno developed; race track proven
- Throttle response; drivability; acceleration
- All alcohol base
- Fuel carbs have hard anodized metering blocks and float bowls

Contact: 520-579-9177  
[braswell.com](http://braswell.com)



### CAM MOTION CAMSHAFTS

- Cam Motion produces high-performance camshafts for traditional engine platforms
- Such as small block Chevy (SBC), big block Chevy (BBC) and Ford V8s
- Also, modern LS, LT, and Gen V engines
- These products enhance valve timing, lift, and duration
- Offering hydraulic roller, solid roller, and VT options, along with supporting components

Contact: 225-926-6110  
[cammotion.com](http://cammotion.com)



### CANTON RACING PRODUCTS ACCUSUMP 3-QT, NO VALVE

- Ideal for V8 and high-horsepower V6 and 4-cylinder engines
- Made In USA
- 16 inches long and 4.250-inch diameter body
- 3-qt capacity

Contact: 203-481-9460  
[cantonracingproducts.com](http://cantonracingproducts.com)



### CHAMP PANS ALUMINUM CIRCLE TRACK WET-SUMP FOR SBC

- 40-plus years of experience of manufacturing quality, high-performance engine products
- Most of the company's oil pans come with a louvered windage tray for increased horsepower and better oil control
- Potential increase of 10-40 horsepower, depending on the style of the oil pan and louvered windage tray
- All oil pans are checked for proper fitment on engine blocks before shipping

Contact: 715-834-7748  
[champpans.com](http://champpans.com)



## POLARIS RANGER TUNED AUDIO ROOFS



## TAKE DOWN ADVENTURE

ALL-NEW MB Quart UTV Tuned Audio Roofs exclusive for Polaris RZR® Trail and Polaris RANGER® UTV vehicles. These UTV Tuned Audio Roofs deliver incredible audio immersion creating a soundscape that brings the ultimate concert listening experience.



## POLARIS RZR TRAIL TUNED AUDIO ROOFS



  [MBQuart.com](https://www.MBQuart.com)  
#MUSICDEFINED

Exclusive for: 2021 - Current Polaris RZR® Trail  
2018 - Current Polaris RANGER®

## HIFONICS COLOSSUS PRO & MINI AMPLIFIERS

ALL-NEW for 2024 — The Hifonics Colossus line of amplifiers expands to PRO and Mini! Elevate your Hifonics audio system with BIGGER PLAYBACK in POWER through the Hifonics Colossus PRO and Mini amplifier series. It's your audio - take it to new levels of detailed performance through Colossus!



## COLOSSUS POWER INFUSED WITH POWER FROM THE GODS

Offering incredible power and loudness throughout every listening session – Hifonics Colossus PRO amplifiers use ULTIMATE POWER and PLAYBACK by bringing out LOUDER LEVELS of detail and sound within audio. Superior performance meets PRO levels of playback while staying protected under nearly every circumstance with triple protection circuits and a PRO thermal management system. Additionally, a delayed turn-on function ensures compatibility with a wide range of source units to eliminate any unwanted turn-on/off noises.



## SMALL PACKAGE, BIG POWER

Innovated in a smaller size with the Colossus Mini line of amplifiers. The smallest size footprint of the Colossus family of amplifiers delivers PRO POWER in a compact size. Delivering POWER FROM THE GODS in compact size where space is tight and limited in your Hifonics audio install – Colossus Mini amplifiers still create higher PRO POWER where you need it the most.

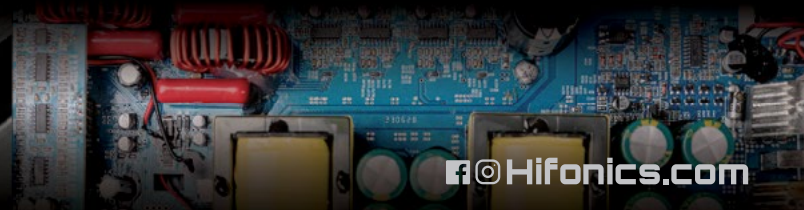

  [Hifonics.com](https://www.Hifonics.com)



### DOC'S DIESEL 6.7L CUMMINS FILTER MAINTENANCE KIT

- Doc's Ram 6.7L/3.0L Cummins fuel/water separator 2019–2024
- Doc's Ram 6.7L Cummins fuel filter 2010–2024
- Doc's Ram 6.7L Cummins oil filter 1989–2024
- Doc's Ram 6.7L Cummins air filter 2007–2024
- Doc's Ram 6.7L/3.0L Cummins cabin air filter 2010–2024

Contact: 419-551-6138

[docsdiesel.com](http://docsdiesel.com)



### FLUIDAMPR-VIBRATECH TVD MAZDA MIATA/MX-5 DAMPER

- Application for 2.0L in 2006–2014 model years
- Crankshaft torsional vibration protection across rpm range
- Reduce risk of crankshaft failure and wear on critical engine parts
- Unleash lost horsepower and torque
- Three 5/16-24 bolt holes on 2.750-inch pattern for custom mandrel and damper puller/installer tool
- SFI 18.1 certified; made in USA

Contact: 716-592-1000

[fluidampr.com](http://fluidampr.com)



### GANDRUD PARTS CENTER LT1 WET-SUMP 455HP

- 455 horsepower, 455 lb.-ft. torque
- Aluminum construction for a lightweight swap option
- Architecturally similar to the LS family
- Latest technology GM has to offer in small block design
- Direct injection for efficient power

Contact: 920-468-3658

[gmperformancemotor.com](http://gmperformancemotor.com)



### GREEN FILTER USA HIGH-PERFORMANCE AIR FILTERS 14-INCH ROUNDS

- Washable, reusable, rechargeable
- Traps particles as small as five microns
- Increased airflow creates more potent air/fuel mixture
- Increased horsepower
- 14-inch rounds available in 2-inch, 3-inch, 4-inch, 5-inch and 6-inch heights

Contact: 724-430-2050

[greenfilter.com](http://greenfilter.com)



### HOWARDS CAMS TRACKSMART 3 CRANKSHAFT

- Non-twist 4340 steel forgings
- Fully CNC machined
- Deep nitride hardening
- Stress relieved and shot peened
- Large fillet radii on all bearing journals
- Improved counterweight placement
- Lightening holes in all rod throws
- Gun-drilled mains
- 750-plus horsepower rating

Contact: 920-230-4241

[howardscams.com](http://howardscams.com)

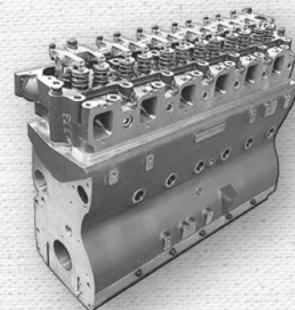

### HYPERMAX ENGINEERING IHC CRANKCASE (SHOWN WITH HIGH FLOW CYLINDER HEAD)

- IHC-compatible crankcase casting
- Water cooled for longevity
- Four-bolt wide main bearing bulkheads with crossbolts
- 28 cylinder head bolt capability
- Thick exterior walls for added strength
- Compatible with all IHC-style cylinder heads
- Designed to utilize most aftermarket accessories

Contact: 847-428-5655

[gohypermax.com](http://gohypermax.com)



# BOOTH 2729



## Complete Ford 9 Rear Ends

Housings | Axles | Third Members | Brake Kits  
Gears | Spools | Differentials | Bearing Kits

### Direct Fit Ford 9" Rear Ends

All New Construction  
Laser-Cut, Jig-Welded Brackets  
Ships to Any Location  
Built-to-Order

Many Options Available Including:

- Custom Widths
- Powdercoating
- Gun-Drilled Axles

Common Complete Rear End Builds:

450HP Street/Strip Rear End Starting at \$2145

1,000HP Drag Racing Rear End Starting at \$2309

(Includes Housing, Axles, Third Member and Brakes)

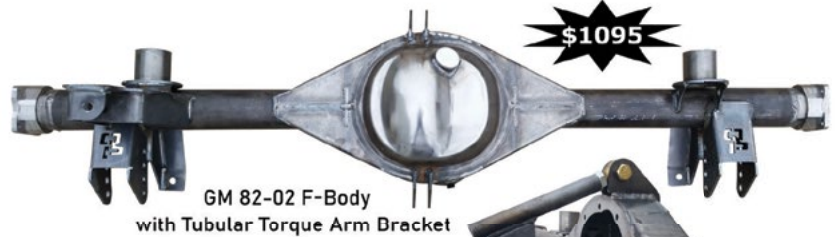

GM 82-02 F-Body  
with Tubular Torque Arm Bracket



1, 2, 4, and 6 Piston Brake Kits



Race Ready Center Sections Starting at \$1040



GM Half-Ton Truck with Flipped Perches



### Applications including, but not limited to

1955-57 Chevy Tri 5

1962-67 X-Body Nova, Chevy II

1968-76 X-Body Nova

1967-69 F-Body Camaro, Firebird

1970-81 F-Body Camaro, Firebird

1982-92 F-Body Camaro, Firebird

1993-02 F-Body Camaro, Firebird

1964-67 A-Body Chevelle, Cutlass, El Camino, GTO, Malibu

1968-72 A-Body Chevelle, Cutlass, El Camino, GTO, Malibu, Monte Carlo

1973-77 A-Body Chevelle, Cutlass, El Camino, GTO, Malibu

1978-87 G-Body Grand National, Monte Carlo, Cutlass, Regal, El Camino

1959-64 B-Body Impala, Bel Air, Biscayne

1965-70 B-Body Impala

1971-76 B-Body Impala, Caprice, LeSabre

1977-90 Caprice, Impala, Delta 88

1991-96 Caprice, Impala

1958 Delray

1961 Cadillac

1969-76 Cadillac de Ville, Fleetwood, Sedan, Limo

1971-80 GM H-Body Vega, Monza, Starfire

1982-02 S10, S15, Sonoma

1960-72 Chevy, GMC Truck

1973-87 Chevy, GMC Truck

1988-98 Chevy, GMC Truck

1999-06 Chevy, GMC Truck [Includes old body style 07]

2007-18 Chevy, GMC Truck

Bonneville, Riviera, Grand Prix

1964-66 Mustang

1967-70 Mustang Cougar, Fairlane, Comet, Falcon

1971-73 Mustang Cougar, Fairlane, Comet, Falcon

1979-93 Mustang Fox Body

1994-04 Mustang SN95

05-14 Mustang S197

1957-72 F-100

1973-86 F-150

1966-77 Bronco

1978-86 Bronco

1970-79 Ranchero, Torino

1969-77 Galaxie, Lincoln

Jeep SRT8

Jeep TJ Rear

Jeep JK Rear

Jeep JT Rear

Land Rover Defender

Ridetech 4 Link

Bare housing with ends (No brackets)

Custom leaf spring

Custom 4-Link

Demolition derby

Grand National bare floater

G-Body Grand National floater

A-Body Grand National floater

**QUICKPERFORMANCE.COM**

**515.232.0126**



### JESSEL SPORTSMAN STEEL ROCKER ARMS

- Jesel Sportsman Steel Rockers blend the innovation of Jesel Pro Aluminum Rockers with the durability of Jesel Pro Steel Rockers
- Ultralight design reduces weight and inertia
- Engineered for turbocharged, supercharged, nitrous, and endurance engines
- Heat-treated alloy steel with black oxide coating for corrosion resistance
- Compatible with existing Pro Aluminum systems

Contact: 732-901-1800  
[jesel.com](http://jesel.com)



### KEN PERRY'S XTREME ARIAS KPXA RACE ENGINE

- Utilizing the most advanced five-axis CAM software, KPXA's capabilities are showcased in the latest concepts of this innovative engine
- Advanced design and manufacturing technologies produce stunning finishes while holding the tightest of tolerances
- This is a newly designed Arias platform with many advancements: raised cam, superior oiling, individual rockers

Contact: 844-777-5792  
[kpxaracingengines.com](http://kpxaracingengines.com)



### KING RACING PRODUCTS INLINE FUEL FILTER WITH SHUTOFF

- All billet construction
- 100-micron stainless element
- Available in #6, #8, #10 & #12 ends

Contact: 559-636-1655  
[kingracingproducts.com](http://kingracingproducts.com)



### LATE MODEL ENGINES VVT-DELETE CAST FRONT COVER BUNDLE

- LME cast front cover, only available in wet sump
- Allows you to delete the factory cam phaser, which is known to fail at high rpm and high boost levels
- Improve performance and reliability
- Cam gear and cam bolt included
- Deletes VVT, eliminates GM phaser
- Easy to install—no fighting the factory phaser when installing a limiter
- Uses single-bolt GM cam gear
- Uses factory sensors and hardware
- Wet sump only O-ring to block
- Lightweight LME billet timing chain guide deletes the factory tensioner that is known to fail—improve performance and reliability
- Retains factory oiling

Contact: 713-849-4505  
[latemodelengines.com](http://latemodelengines.com)



### MAHLE AFTERMARKET CLEVITE F-SERIES ENGINE BEARINGS

- 126% increase load carrying capacity before seizure vs. conventional H-series bearings
- Increased fatigue strength and wear resistance overlay
- Higher seizure resistance vs. coated bearing—no additional thickness
- Ramp and pad designed thrust face: 93% thrust load increase vs. flat pad thrust design

Contact: 947-944-5592  
[mahle-aftermarket.com](http://mahle-aftermarket.com)



### MAHLE MOTORSPORTS DURAMAX L5P POWERPAK PISTON KIT

- Announcing two new cast-aluminum alloy PowerPak piston kits for Duramax L5P
- PN 197987855 delivering 16.0:1 compression ratio
- PN197987955 offers 0.075 in valve relief pockets, delivering 15.7:1 compression ratio
- Steel keystone 3.0 mm top ring, 2.0 mm 2nd ring, and 3.0 mm oil ring
- Available in standard, 0.020 in, or 0.040 in bore sizes

Contact: 888-255-1942  
[mahlemotorsport.com](http://mahlemotorsport.com)

# **REBUILDABLE CORE ENGINES, HARD PARTS TRANSMISSIONS**

**KB Cores** has been in business since 1993, offering a wide variety of foreign and domestic rebuildable engines, transmissions, and parts. Located in Kankakee, IL, our 250,000 square foot facility processes over 1,000 cores a day and is stocked with the widest variety of parts that your business needs.

## **Our service:**

- ✓ Friendly and knowledgeable sales team
- ✓ Quality products at a reasonable price
- ✓ International shipping at competitive rates



### **Contact Us:**

-  800-822-2673
-  [www.kbcores.com](http://www.kbcores.com)

**COME MEET US AT PRI  
BOOTH #3073**





### MASTA PERFORMANCE 4L80E TRANS TO BBC DIPSTICK & TUBE

- New direct-fit dipstick and tube
- Fits 1968–1970 Camaro and Chevelle
- Others coming soon

Contact: 248-685-8710  
[mastaperformance.com](http://mastaperformance.com)



### NITROUS EXPRESS COVERT CROSSBAR PLATE SYSTEM

- Maximize performance with Nitrous Express's brand-new Covert Crossbar plate system
- This innovative system installs inside your intake manifold, eliminating the need for costly cowl hoods
- With the nitrous and fuel inlets discreetly placed toward the firewall, you get a completely hidden setup that delivers unmatched distribution and maximum performance

Contact: 940-767-7694  
[nitrousexpress.com](http://nitrousexpress.com)



### NORTHERN RADIATOR RACE PRO SINGLE ROW RADIATORS

- New single row, all-aluminum design delivers effective cooling in a lightweight package
- Double-pass version with 1 5/8-inch tubes or ultra-lightweight single-pass version with 1 1/4-inch tubes
- Available in multiple sizes
- 1 3/4-inch inlet and outlet on all models
- Same quality features from Northern's Race Pro Radiators

Contact: 800-328-8900  
[northernradiator.com](http://northernradiator.com)



### OUTERWEARS PRE-FILTERS

- Founded 45 years ago
- Created to fulfill need to keep air filter and engine clean of sand, dirt, and other debris during off-road racing because of premature packing (clogging) of the filter. Filters loading up with dirt means loss of horsepower and in many cases loss of a race, and engine damage
- Designed to keep out additional dirt without interfering with airflow

Contact: 269-679-3301  
[outerwears.com](http://outerwears.com)



### P1 MANUFACTURING FORD GODZILLA S220 HEAD- STUD KIT

- P1 introduces the S220 head stud kit for 7.3L Godzilla engines
- Featuring 220,000 psi tensile strength
- Ideal for high-performance applications
- Kit includes vacuum heat-treated 12-point nuts, parallel ground washers, and S220 studs with a clamp force of 20,100 lbs.
- All packaged in premium vacuum-sealed bags

Contact: 417-753-5174  
[p1mfg.com](http://p1mfg.com)



### PACIFIC PERFORMANCE ENGINEERING ZILLA CARBON-FIBER TURBO INLET TUBE

- For GM 6.6L Duramax (2017–2024)
- 50 States Emissions Legal (E.O. D-701-42)
- 100% genuine, dry/prepreg carbon fiber construction
- Easy, bolt-on installation with no tuning required
- Kit includes stainless steel clamps and PPE five-ply silicone couplers
- Eliminates stock restrictive resonator and improves airflow
- Available in two carbon-fiber appearances: twill weave and forged

Contact: 725-238-2002  
[ppepower.com](http://ppepower.com)



# QUANTUM

M A C H I N E R Y G R O U P

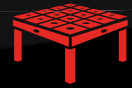

YOUR TRUSTED PARTNER FOR METALWORKING MACHINERY & WELDING TABLES

**+ FREE SHIPPING**  
FOR THIS BUNDLE ONLY

MP3003CNC: 10 Foot x 140 Ton  
Hydraulic Press Brake

MADE IN SPAIN



## THE ULTIMATE METALWORKING TRADE SHOW SPECIAL BUNDLE

GET THIS PRESS BRAKE, WELDING TABLE SETUP & COLD SAW FOR:

# \$99,000

BUNDLE VALUE OF \$141,924

NEW 350 EDV:  
14" Manual Cold Saw  
MADE IN ITALY



**LIMITED-QUANTITY BUNDLE**  
SECURE YOUR BUNDLE TODAY  
PRICING IS VALID UNTIL 12/31/24

USQM28100.XD7: System 28  
4'x8' Imperial Series  
Welding Table  
43 Piece Bundle  
MADE IN GERMANY



\*PRICES ARE SUBJECT TO CHANGE WITHOUT NOTICE, VALID WHILE SUPPLIES LAST

SCAN HERE  
TO ORDER THIS  
BUNDLE TODAY



### LIMITED-QUANTITY MACHINERY SPECIAL

NEW LINE 350 CUTTING LINE



SCAN TO ORDER  
THE NEW LINE 350



# \$85,000

LIST: \$129,000 +SHIPPING

\*PRICE IS VALID UNTIL 12/31/24, DOES NOT INCLUDE SHIPPING AND ARE SUBJECT TO CHANGE WITHOUT NOTICE

QUANTUMMACHINERY.COM  
(704) 703-9400

ALL IN-STOCK ORDERS SHIP WITHIN  
1 TO 3 BUSINESS DAYS  
WE STOCK THOUSANDS OF WELDING TABLES,  
MACHINES, AND TOOLING IN THE USA.



### PERFORMANCE DISTRIBUTORS DYNA-BATT

- Lightweight, only 13.5 pounds
- Easy starting
- Fast current flow
- Dry cell—no liquid or gel
- Recharges quickly

Contact: 901-396-5782

[performancedistributors.com](http://performancedistributors.com)



### PERMATEX FUEL RESISTANT MOTORSEAL GASKET MAKER 29132

- Resistant to all automotive fuels
- Ideal for case halves, fuel pumps, and fuel sending units
- Temperature ranges -65 degrees F to 400 degrees F

Contact: 440-248-6120

[permatex.com](http://permatex.com)



### PIPER CAMS FORD ECOBOOST 2.3L PERFORMANCE KITS

- Powerband 2,000–7,500 rpm
- Increased valve lift and duration for optimum performance
- Enhanced mid- to top-end power
- Performance double valve springs
- High-quality materials
- Precision CNC manufacturing

Contact: +44 (0) 1303 245300

[pipercams.co.uk](http://pipercams.co.uk)

# UNRIVALED PERFORMANCE SPAL ELECTRIC COOLING FANS



Crafted by professionals for professionals, SPAL electric cooling fans provide extreme reliability, superior durability and unrivaled performance under the most challenging conditions that is second to none. Stop by our booth (#1435) at the 2024 PRI Show to see the latest in cooling technology from SPAL!



**SPAL AUTOMOTIVE USA**  
PHONE: (800) 345-0327  
EMAIL: [INFO@SPALUSA.COM](mailto:INFO@SPALUSA.COM)  
WEB: [WWW.SPALUSA.COM](http://WWW.SPALUSA.COM)



**POWERMASTER PERFORMANCE  
POWERMASTER HPR PRE-SET  
VOLTAGE ALTERNATORS**

- Designed to support 14- and 16-volt batteries (16.8, 17.5, or 18.2 volts)
- Available for late-model GM, Ford, and Dodge engines in 175- or 250-amp outputs, CW or CCW rotation, pulley sizes and terminal locations
- Coyote alternator shown charges at 18.2 volts, up to 250 amps, with a 3.5-inch pulley for high rpm

Contact: 630-957-4019  
[powermasterperformance.com](http://powermasterperformance.com)

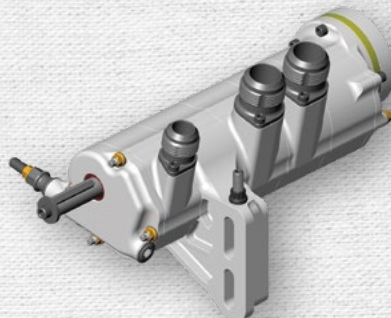

**PRECISION RACING COMPONENTS  
PRC DIRT LATE MODEL OIL  
PUMP**

- Five or six stage
- Dry sump oil pump

Contact: 317-248-4764  
[prc-mfg.com](http://prc-mfg.com)



**PROCHARGER SUPERCHARGER  
SYSTEMS  
LT ENGINE INTERCOOLED  
INTAKE MANIFOLD**

- Billet intake manifolds with integrated air-to-water intercoolers
- Efficient charge-air cooling with slim design
- Capable of cooling 1,200-plus horsepower
- Engineered to accept a supercharger, stock accessory drive, and fit nearly all component packaging

Contact: 913-338-2886  
[procharger.com](http://procharger.com)

**BURDICK'S  
RV Center**

WE ARE YOUR FULL LINE  
RENEGADE DEALER



RENEGADE XL



RENEGADE CLASSIC



UNITS IN STOCK,  
CALL US FOR DETAILS!

**WWW.BURDICKSRVCENTER.COM**  
**315-652-3764**



### PRW POWER ELITE SERIES STAINLESS STEEL ROLLER TIP ROCKER ARMS

- Equipped with pressure-fed bearings, which enhance lubrication via direct oiling and reduce friction, improving overall performance and longevity
- Lightweight roller tip and precision-ground nose roller further minimize friction and wear
- 14% lighter than previous versions, which enhances performance by reducing valvetrain mass

Contact: 310-863-0569

[prw-usa.com](http://prw-usa.com)

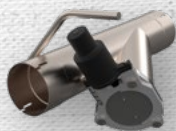

### QUICK TIME PERFORMANCE QTP AGGRESSOR CUTOUT PIPE FOR SILVERADO 2500HD

- For 2020–2024 Chevrolet Silverado and GMC Sierra 2500 6.6L EC/SB, CC/SB 143.5-inch wheelbase
- Aggressor is an electric cutout pipe kit that is vehicle specific
- Designs each application for the best clearance, sound, and power
- There's no need to figure out your install location
- All of the guesswork has been done for you
- Most kits eliminate the need for any welding at all
- Go from factory quiet to Aggressor riot
- Simply bolt in and unleash
- All systems are stainless steel for clean look and made in the USA

Contact: 864-913-1999

[quicktimeperformance.com](http://quicktimeperformance.com)



### S&S DIESEL MOTORSPORT ORDNANCE INJECTORS

- Custom-built specific to engine combustion recipe and application
- For max-effort competition purposes
- Internally modified to complement high nozzle flow
- Large injection quantity with crisp opening and closing events
- Balanced to within 3% variance per set with matching rate shapes
- Test report included, complete map optional
- Duramax, Cummins, Power Stroke, Caterpillar

Contact: 812-521-0123

[ssdiesel.com](http://ssdiesel.com)

# Sander

MADE  USA

Our team looks forward to reconnecting, assisting, and serving your racing parts needs and questions for the 2025 season

Please stop by our booth at PRI 2024, to see the newest innovations and products that have made Sander an industry leader for more than 46 years.

THE BEST AMERICAN MADE

# WHEELS + COMPONENTS

## #1 FOR CUSTOMER SERVICE

DRAG | SPRINT | MIDGET | MICRO



DEC 12 - 14, 2024 | INDIANAPOLIS



310.534.1210  
[SanderEngineering.com](http://SanderEngineering.com)

VISIT OUR BOOTH

# 1043

PRI SHOW 2024





**SCE GASKETS**  
**VULCAN CUT-RING HEAD GASKET**

- Vulcan Cut-Ring head gasket for Ford SB Windsor CR361839
- Hybrid design forged to harness the best sealing properties of two head gasket types
- Composite body with stainless steel rings and silicone bead seal

Contact: 661-728-9200  
[scegaskets.com](http://scegaskets.com)



**SCHUMANN'S SALES & SERVICE**  
**SBC OIL PUMP AND GEARS**

- 12 patents issued, pending, and applied for
- Energy recovery
- Paddle wheel
- 140 ball valve
- Dimple tech
- Anti-cavitation
- PI intake port
- O-ring sealing
- FPS feet per second

Contact: 563-381-2416  
[schumannssalesandservice.com](http://schumannssalesandservice.com)



**SPAL AUTOMOTIVE USA**  
**30107328 - 16", 500W, SEALED BRUSHLESS ELECTRIC FAN**

- Utilizes the same mounting footprint as SPAL V A18 and VA33 brushed fans
- Rated at 2,433 CFM
- Fully sealed IP6K9K motor (waterproof/dustproof)
- Features "soft-start" technology that eliminates electrical in-rush spike
- Integrated power and signal electronics
- Temp sensor for full variable speed control
- Extremely long-lasting motor life

Contact: 800-345-0327  
[spalusa.com](http://spalusa.com)

**ATAC™ FAMILY OF PRODUCTS**

**CONTROL BOTH HEAT & SOUND WITH PRODUCTS DESIGNED TO WORK SEAMLESSLY TOGETHER.**



SEE ALL NEW PRODUCTS AT  
**PRI BOOTH 301**



ATAC COATING - 1 STEP SOLUTION TO CONTROL BOTH HEAT & SOUND



**NEW**  
SEAM SEALER TO BARRIER OUT WATER & SEAL GAPS

**NEW**  
PRIMER FOR THE PERFECT SURFACE



**800.264.9472 DesignEngineering.com**







Specializing In LS, LT,  
Hemi, SBC, BBC, SBF,  
BBF, & Mopar

Visit Us @

**CAMMOTION.com**

**Booth 2307**



### STAINLESS WORKS MUSTANG GT HEADERS

- 1-7/8-inch or 2-inch primary tubes
- 3-inch collector with integrated merge spike
- Connection options: Factory connection fits to stock exhaust - 2-1/4 inches; Performance connection fits Stainless Works catback - 3 inches; Aftermarket connection fits most aftermarket catbacks - 3 inches (may require cutting)
- Add horsepower and torque with this bolt-on upgrade
- 304 stainless construction will last a lifetime
- Smooth mandrel bends optimize exhaust flow
- Fully TIG welded for strength and beauty
- Multiple connection options to match your build

Contact: 800-878-3635

[stainlessworks.net](http://stainlessworks.net)



### T&D MACHINE PRODUCTS ROCKER ARMS

- Latest from T&D is a direct bolt-on set for the Brodix BRX18
- It's based around a rigid one-piece mounting stand that provides rock-solid mounting for improved valvetrain stability and valve lash consistency
- Internal oiling to the trunion bearings and roller tips
- Larger shafts, bearings, adjusters, and jam nuts
- For higher stress applications, steel rocker bodies are available
- Ratios from 1.7:1 to 2.0:1
- T&D always means higher-grade components and fine customer service

Contact: 775-884-2292

[tdmach.com](http://tdmach.com)



### TOP STREET PERFORMANCE 81601 CARBON FIBER INTAKE MANIFOLD LID - 102 MM

- Brings the TSP Hi-Ram intake to new heights by combining performance and aesthetics
- Lightweight carbon-fiber plenum upper reduces weight and heat soak while featuring an eye-catching exposed weave finish

Contact: 562-926-5858

[topstreetperformance.com](http://topstreetperformance.com)



### UNITED ENGINE & MACHINE CO. ICON FORD COYOTE FORGED PISTONS

- Fit 2011-2017 Ford Coyote Mustang (part no. IC10167)
- Floating wrist pin
- Forged 4032 alloy
- Fully machined crowns to OE specifications
- UEM's M42 anti-friction skirt coating
- Type 3 hard-anodized top ring groove and crown
- Also available for F-150 (part no. IC10168)

Contact: 775-882-7790

[uempistons.com](http://uempistons.com)

# THE OFFICIAL TECH SCALES

TRUSTED BY 20+ RACING ORGANIZATIONS

SW650RFX™ WIRELESS  
QUIK WEIGH™ Scale System



MICROFLEX™ WIRELESS  
Scale System



VISIT US AT THE

## **PRI** SHOW

DECEMBER 12-14, 2024 | INDIANAPOLIS

**Booth #1401**

Attend our  
**Shock Dyno & Load Stick  
Seminar**

12/12 & 12/13  
in Rm 205



Tablet not included



## **Intercomp Wireless Scale Systems**

- Bluetooth Communication to a Tablet/Device with iRaceWeigh
- 6061-T6 Billet Aluminum Scale Pads
- Designed, Built & Supported in the USA



intercompracing.com  
+1763-476-2531

**Intercomp**  
advanced weighing technology... by any measure



SECTION

2

# CHASSIS, DRIVELINE & SUSPENSION COMPONENTS

Complete a race car build with the numerous products found on the following pages. From brakes to transmissions and shocks to hoods, these suppliers have your chassis, driveline, and suspension needs covered.



Scan Here



**TRANSFORMED  
TO NEW HEIGHTS WITH**



## ATL RACING FUEL CELLS

atlltd.com | 201-825-1400

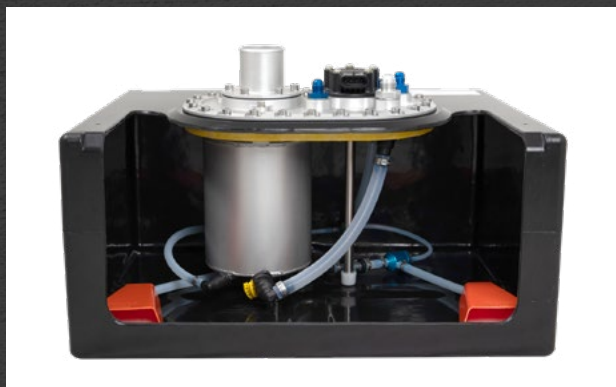

### ATL VORTEX PRO

- Innovative top plate design that utilizes a venturi system feeding a unique pressurized accumulator in place of a collector fed by lift pumps
- Accumulator means no pressure dropouts at low fuel loads and improved temperature characteristics
- No in-tank wiring and no pass-through wire connections increases safety and decreases maintenance within fuel cell



### ATL PORSCHE DUAL DRY-BREAK KIT

- Converts the standard filler neck found on the latest 911 GT3 Cup and Cayman GT4 to a dual, 2-inch female dry break valve for quick refueling applications when using a bottle or rig
- Utilized in the Michelin 992 Endurance Cup
- Bolt-in solution, no modification to fuel cell required



### ATL FIA HATCHBACK CONTAINER

- A vital component for race and rally vehicles, ensuring fuel cells located in the driver's compartment are safely covered, as per regulations
- Specifically engineered to work seamlessly with all ATL 6 x 10 top plate configurations, providing a robust and regulation-compliant solution to safeguard the fill plate and filler



### ATL 4 GALLON (15L) RACELL

- The new 4-gallon (15 liter) Racell is FIA FT3 approved and includes a FIA hologram for worldwide compliance
- Constructed from a rugged roto-molded polymer, the ATL Racell is all-fuel compatible and is ideal for time attack, hill climb, autocross, and drag racing

# AUTOMATIC TRANSMISSION DESIGN

autotransdesign.com | 262-251-7777



## TURBO 400 VALVEBODIES

- Complete lineup of valvebodies for every TH400—13 distinct styles and counting
- Manual valvebodies available with or without transbrake function
- Multiple shift patterns, three speed/two speed, clean/safe neutral options, engine braking options
- Available in US domestic billet aluminum and OE cast iron



## TURBO 350 VALVEBODIES

- Brand new lineup of valvebodies for every TH350—six distinct styles and counting
- Manual valvebodies available with or without transbrake function
- Reverse shift pattern, three speed, engine braking options available
- Available in US domestic billet aluminum and OE cast iron



## 4L80E VALVEBODIES

- Transform your hotrod or race car with this lineup of 4L80E valvebodies
- Manual valvebodies available with or without transbrake function, and with or without converter lockup
- Six different styles and counting
- Available in US domestic billet aluminum and select OE-based options

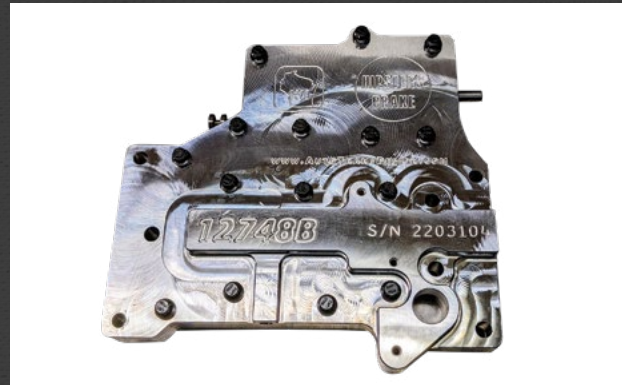

## POWERGLIDE VALVEBODIES

- Hipster's Brake Powerglide transbrake valvebodies
- Choose from a fast billet aluminum brake or the original cast iron Hipster Brake while cores last
- High gear leave and internal converter feed dump options available

## CALVERT RACING

calvertracing.com | 661-728-9600



### CALTRACS

- Patented Traction Bar system, axle above or below springs
- Hooks your vehicle, especially on hard acceleration
- Improves consistency and 60-foot times
- Keeps axle from rotating, maintains pinion angle
- Low-profile, drag racing, and Monster kits available
- Made in USA



### LEAFSPRING SLIDERS

- Replaces existing worn factory shackles
- Metal-on-metal bearings reduces friction
- Virtually eliminates body and spring binding
- Bearing track angled for best torque on movement
- Made for Calvert Springs, 1955–1957 Chevy, and factory springs for 1500, S10, and GM
- Made in USA



### CALVERT PATENTED PERCHES

- Fully enclosed for added strength
- Heat penetration tabs, requires welding
- Unlike factory perches, extends above center line of axle for stability and strength
- Available in axle diameters of 2.25 inches – 3.5 inches
- Requires welding to axle
- Made in USA



### ROD ENDS/HEIM JOINTS

- Replace rod ends on CalTracs force transfer link bars
- Radial static load capacity over 14,000 lbs.
- Cars and light-duty truck standard rod ends now include grease zerk to reduce rattle
- HD heavy-duty truck and Monster/Big Link rod ends available
- Easy to adjust; turning can add up to an extra 3/4-inch in bar length



# Comec CNC

1/3 the Cost of the Competition!



**ACF200CNC**

**Boring and Surfacing Mill**

**See Our Complete Line of Equipment at PRI 2024!**

**Comec, Inc.**  
7807 Addison Road  
Masury, OH 44438



**800-887-6076**



[www.comecus.com](http://www.comecus.com)



[info@comecus.com](mailto:info@comecus.com)

# COMPETITION CLUTCH

competitionclutch.com | 714-410-1958



## 184 SERIES MULTI-PLATE CLUTCH KITS

- Twin and triple disc clutches provide an economical racing clutch for sport compacts
- These ceramic clutch kits come with a 4140 forged flywheel and 6061 T6 aluminum cover complemented with a 6150 steel diaphragm
- Rated to hold 1,000 to 1,500 hp (depending on application) and ready for your abuse



## COMPETITION CLUTCH CHROMOLY FLYWHEELS

- Made with 4140 Chromium-molybdenum forged steel and will allow your vehicle to tap into its true potential
- Providing a larger and smooth rpm range and balanced for perfect harmonics
- Check the Competition Clutch catalog and see what option fits your car



## COMPETITION CLUTCH STAGE 3 SINGLE DISC CLUTCH KIT

- Stage 3 2600 Clutch Kits provide up to 150% increase in torque capacity
- The segmented ceramic material and performance pressure plate will provide the ultimate grab for street or strip
- Provides quick yet smooth engagement
- The kits may also include a throw-out bearing, pilot bearing/bushing, and alignment tool



## COMPETITION CLUTCH STAGE 4 1620 CLUTCH KITS

- Stage 4 1620 Clutch Kits provide up to 250% increase in torque capacity
- This kit contains a six-puck, high-torque disc with ceramic buttons—good for penetrating engagement with higher horsepower applications
- The kits also include a performance pressure plate, throw-out bearing, pilot bearing/bushing, and alignment tool



# ENERGY APEX SERIES

Stop by booth 4711 at the PRI Show to see the latest innovations from Callies Performance Products

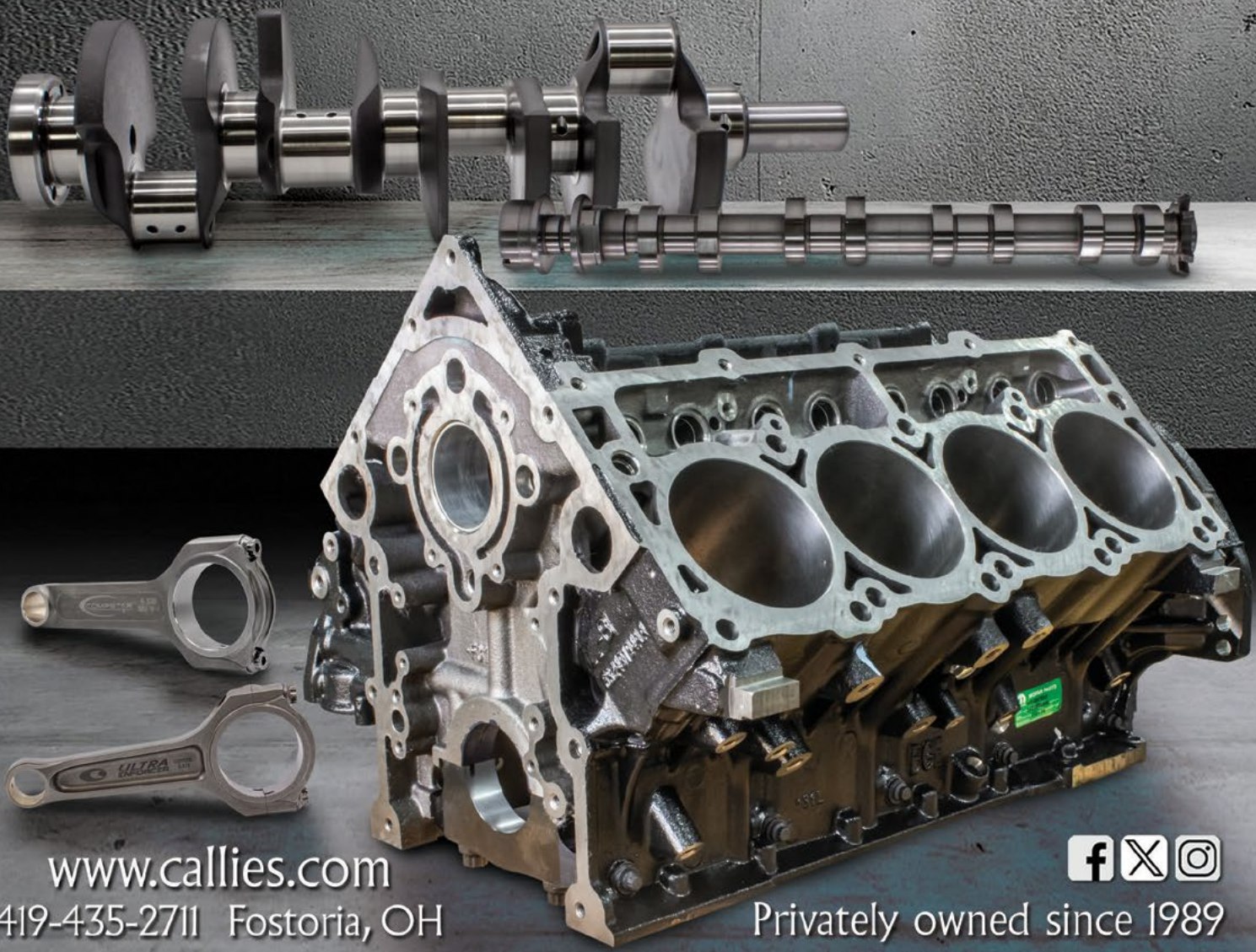

[www.callies.com](http://www.callies.com)  
419-435-2711 Fostoria, OH



Privately owned since 1989

## FTI PERFORMANCE

ftiperformance.com | 386-736-5816



### POWERGLIDE LEVEL 5 TRANSMISSION

- Rated to 1,500 hp
- SFI-certified aftermarket case
- FTI billet aluminum valvebody
- Deep aluminum pan
- 8 clutch drum
- New straight-cut planetary
- Proprietary alloy high-flow billet input shaft and 4340 billet output shaft
- New 7 bolt high-volume pump



### TWO-PIECE POWERGLIDE CASE

- Removable bellhousing
- Bushing-style case
- Fits LS and LT engines
- SFI-certified
- Utilize with aftermarket Ford or Chrysler bellhousings



### SS8 "SNOWMAN" SERIES 8" RACING CONVERTER

- Built with entirely new parts
- Available in spragless or mechanical diode
- CNC-machined stators available in steel and aluminum

# JONES

Racing Products.com



72 Annawanda Road • Ottsville, PA 18942-9702 • (610) 847-2028 (610) 847-8895

## DIRT LATE MODEL

Dual-dowel front design allows pulleys to be added for race or dyno



Large billet crankshaft nut. Independent balancer bolt for strength & weight savings



Proper Belt Size Provided no tensioner is required increasing efficiency & reliability

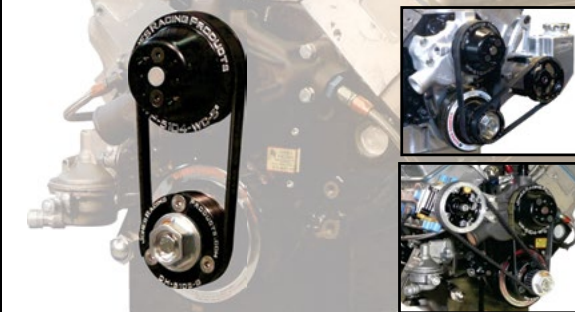

## PS-9008-AL-AR

Lightweight Alum. PS Pump with Built-in High-Capacity Alum. Tank



## Low Drag Asphalt

Positive-Engagement Radius Tooth Belt Drive w. Billet Aluminum Pulleys



High Capacity Fabricated Aluminum Power Steering Reservoir



Mini One-Wire Alternator 75 Amp High-Output 6 Lb. Lightweight Design

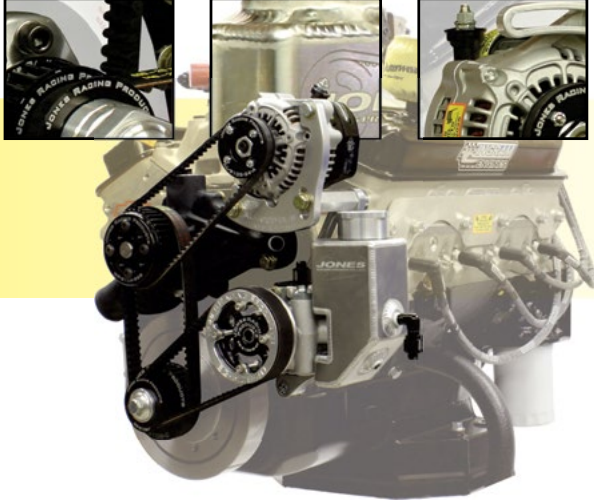

## 602/604 CRATE

SBC Circle Track Complete Front Drive

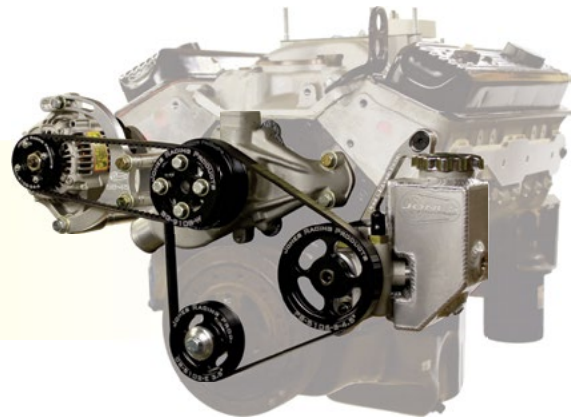

## DIRTcar

Positive-Engagement Radius Tooth Belt Drive w. Billet Aluminum Pulleys



1/2" Thick Billet Alum. Bracket Supplied with Proper Length Billet Spacers & Hardware



Mini One-Wire Alternator 75 Amp High-Output 6 Lb. Lightweight Design

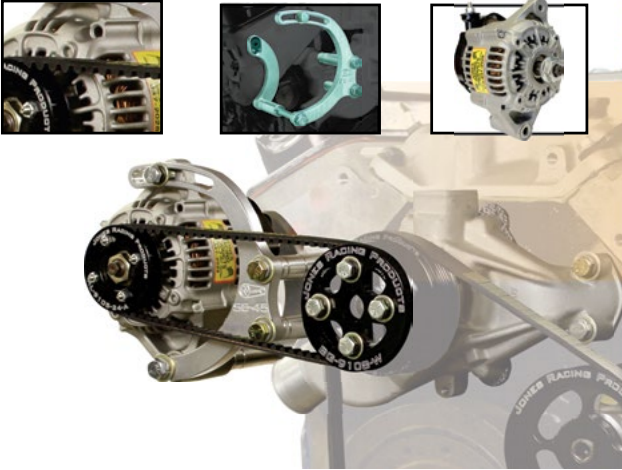

## WP-9104-17-H3

Lightweight 3-Blade Fan



WP-9104-17-H3  
Also available in:  
14, 15, 16, 17, 18 & 19"

## HUSTLER 3-Blade Fan

## GFX CORP

gfxcorp.com | 305-499-9789



### POWERGLIDE PUMP

- Brand new pump for Powerglide transmissions



### TH350 ALUMINUM PAN

- TH350 deep pan made in aluminum



### 10R80/10R60 DEEP ALUMINUM TRANSMISSION PAN

- This new deep pan comes with drain plug and fins for extra cooling

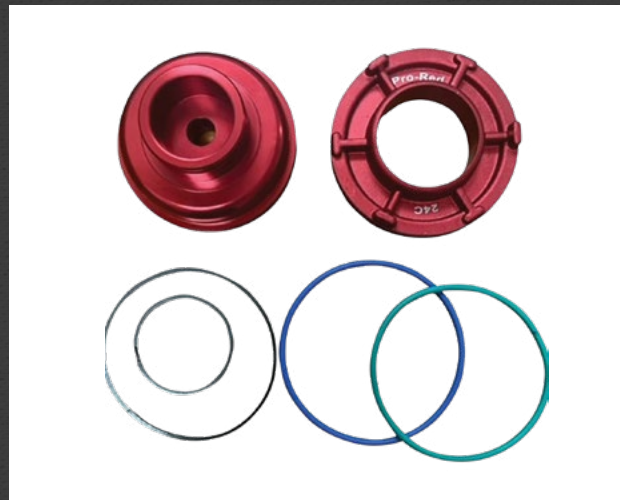

### TH700/4L60E SERVO PISTON

- The Corvette-style aluminum piston is now anodized in red and comes in a plastic case to protect the product and give a better selling appearance

# SERIOUS PERFORMANCE.

SERIOUS WHOLESALE POWER BY ATECH MOTORSPORTS.

- Access to Over 1,500 Brands
- Unbeatable Service and Satisfaction
- Huge Inventory—We Stock it so You Don't Have to
- Four National Warehouses
- FAST, FREE Shipping
- We Export at Competitive Rates

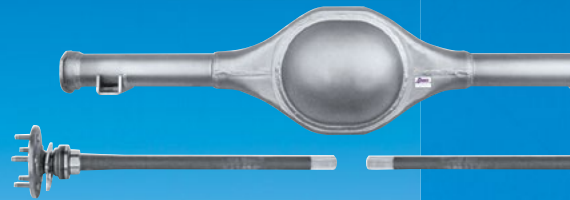
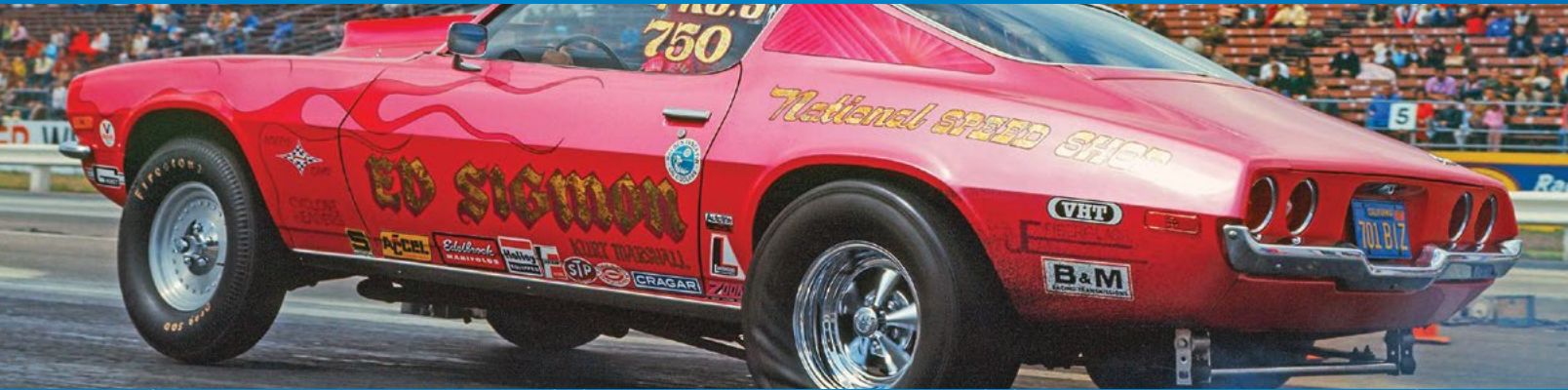

**TRACKSPEC**  
MOTORSPORTS

**IMPROVED**  
RACING

**longacre**  
RACING PRODUCTS

**INNOVATE**  
MOTORSPORTS

**Dr. Soldier**  
RACECARS

FEATURED  
BRANDS

APPLY  
TODAY!

**ATECHMOTORSPORTS.COM**  
FOUR LOCATIONS—MILLIONS OF PARTS!

**ATECH**  
MOTORSPORTS

Global Wholesale  
DISTRIBUTOR

TALLMADGE, OH • MCDONOUGH, GA • SPARKS, NV • ARLINGTON, TX  
800.517.1040 • 1.330.630.0888 • FAX: 1.330.630.5365

Some parts are not legal for sale or use in California or other states with similar laws/regulations. Please check your state and/or local laws/regulations. Typographical errors and errors in description or photography are subject to correction. ©2024 AUTOSALES, INC.

Powered by **SUMMIT**  
RACING EQUIPMENT

WHSE24PR

## MCLEOD RACING

mcleodracing.com | 714-630-2764



### RXT TWIN DISC CLUTCH KIT

- Intended for the high-horsepower street/strip fan, the McLeod RXT Street twin clutch kit is able to handle 1,000 hp. This clutch can handle almost any horsepower you can throw at it and still remain street-able
- Ceramic lined clutch discs will provide smooth engagement with a soft pedal effort to make this clutch kit ideal for the street performance enthusiast
- This clutch is perfect for the person who wants the best of both worlds

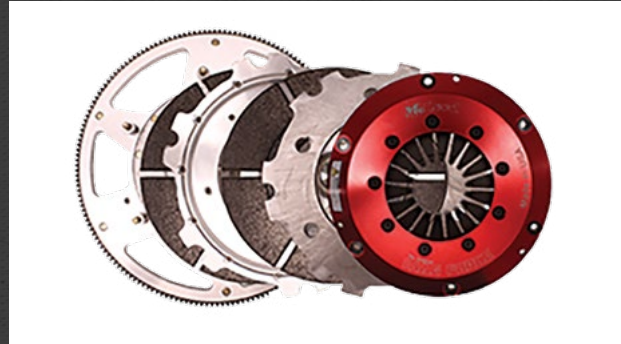

### MAG FORCE CLUTCH KIT

- Mag Force SE—rated up to 700 hp, this clutch system is perfect for high-horsepower street cars in both import and domestic applications
- With a billet aluminum cover, ceramic discs, this is your ideal clutch for the street or road racing, drag racing, and salt flats time trials



### MINI MAG CLUTCH KIT

- With NHRA Top Fuel proven technology, these 7 1/4" clutch kits have friction material

designed to endure the required slippage of drag racing

- With multiple diaphragm spring pressures, this clutch is able to suit individual applications. It has a high clamp-to-wear ratio, low moment of inertia, and has an open clutch cover design to keep the unit running cooler under heavy use
- The kits can be ordered single-, twin-, or triple-disc configurations. These kits include a racer rebuildable disc and floater packages along with replacement part availability
- The clutch is manufactured to high precision tolerances to keep fitment and assembled concentricity perfect, which help reduce harmful resonances within the engine and drivetrain
- Kits are designed to fit most 7 1/4" industry standard flywheel bolt patterns with .100 pull down. These kits are available for Chevy, Ford, Honda, Toyota, and many other vehicles
- All components are made from billet aluminum or steel



### 7.25" SAND RAIL 4 PLATE CLUTCH KIT

- The McLeod 7.25" 4 Disc Assembly is built to tame over 2,000 hp
- Every component is precision-matched. With a smooth, soft pedal feel, the kit offers effortless control with massive power at your command
- Equipped with premium ARP hardware to ensure durability and reliability on the roughest rides



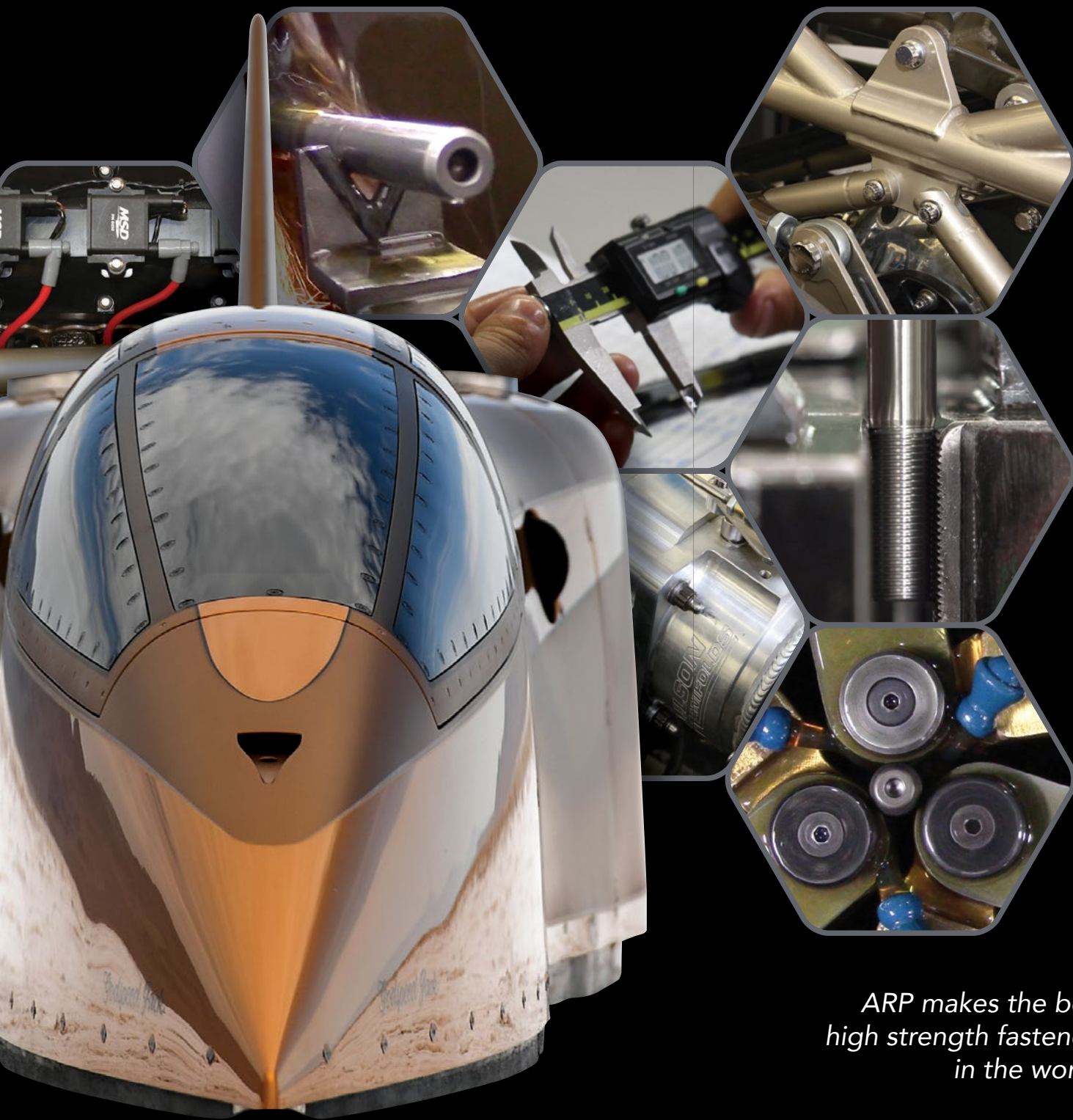

Speed Demon Racing won its 12th Hot Rod Trophy and set its 24th land speed record running custom and off-the-shelf ARP fasteners.

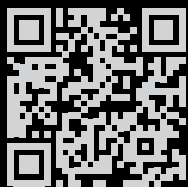

And now,  
it's literally  
driven by ARP.  
Scan for  
the full story

ARP makes the best  
high strength fasteners  
in the world.

We don't stop there.  
We get behind the wheel and prove it.

**ARP**  
automotive *Racing* products

arp-bolts.com • 1.800.826.3045

# SILVER SPORT TRANSMISSIONS

shiftsst.com | 865-609-8187

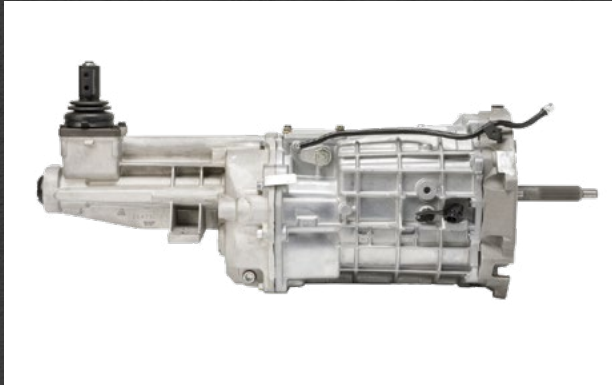

## TRECMEC MAGNUM XL 6-SPEED

- Direct replacement for 2005 and up S197 Mustangs with an extended tailhousing to eliminate the semi-remote shifter for radically improved shift feel and overall performance
- 700 lb. ft. torque capacity and 7800 rpm shifts
- The longest TRECMEC available, it is a great fit for many late model applications



## STX SHIFTER

- Bolt-on replacements for a wide variety of TRECMEC OE and aftermarket transmissions
- Bench seat clearing front shift kits available for TKO, TKX, and Magnum as well as some T56 models
- Engineered in-house to be compact with short, positive, smooth, and fast throws



## TRECMEC TR-4050 5-SPEED WITH OD TRANSMISSION FOR 4WD VEHICLES

- 600 lb. ft. torque capacity
- Ultra-low 6.16 first gear with a 0.76 overdrive, it's perfect on and off the trail
- Completely synchronized in all forward and reverse gears for smooth shifts

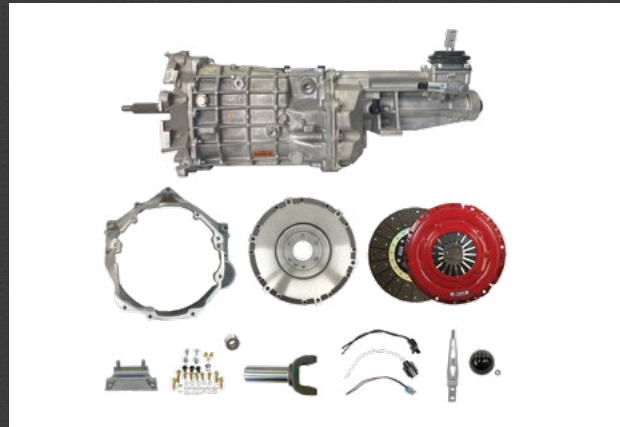

## 2010-2015 GEN 5 CAMARO MAGNUM XL KIT

- Complete kit for easy installation
- 700 lb. ft. torque capacity and 7800 rpm shifts
- Eliminate the semi-remote shifter for improved feel and overall performance with the extended reach of the Magnum XL



**Now with Duramax L5P**

## UNLOCK YOUR VEHICLE'S **MAXIMUM POTENTIAL!!!**

Put the right tools in your toolbox! **FlashScan V3** from EFILive allows you to scan, data log and reprogram your vehicle for maximum performance and outstanding drivability.

### **FLASHSCAN V3 SPECIFICATION:**

- ✓ Fully integrated Scan and Tune Tool.
- ✓ All new V8 tune file editor.
- ✓ Integrate your custom calibrations into the V8 editor.
- ✓ Light duty (CAN J1979, VPW J1850) and Heavy duty (CAN J1939) protocols.
- ✓ Supports 600 VIN Licenses.
- ✓ Large, easy to read color screen.
- ✓ Built in 512MB micro SD Card.
- ✓ Built-in audible alarms.
- ✓ Upgradable firmware.
- ✓ Vehicle input voltage - Min 9V, Max 28V.
- ✓ Battery backed real-time clock.
- ✓ Appears as a Windows USB drive.
- ✓ Built-in power supply prevents data corruption if external power supply is interrupted.
- ✓ Customize menus, colors and images.
- ✓ Read & clear DTC codes.
- ✓ High speed data logging.
- ✓ Display data while logging.
- ✓ Read & program calibration & operating system data of engine controller.
- ✓ Integrates with AutoCal V3 to deliver your own custom handheld tuning device.
- ✓ Automatic saving of trace files.
- ✓ Internet connection not needed for flashing or editing.

### **FLASHSCAN & AUTOCAL V3 COMPATIBILITY:**

**FlashScan V3 & AutoCal V3** can be used with the following controllers:

- » Most 2006-2021 Dodge Cummins 5.9L & 6.7L
- » Most 1998-2021 GM Gas Vehicles
- » 2001-2023 Duramax 6.6L
- » 2014-2021 Duramax 2.8L
- » Most 2007-2021 Cummins HD Controllers
- » EFILive supported TCMs may flash without licensing or credits.



**FlashScan V3 with one Tuning option US\$1025.00**

**AutoCal V3 as low as US\$290.00\***

\*Quantity discounts available

**www.efilive.com**



# SLADE PRECISION SHOCKS

sladeprecisionshocks.com | 704-232-1127



## COPPERHEAD DOUBLE ADJUSTABLE

- Copperheads offer a wide range of low speed adjustment
- No expensive mechanisms in the shaft making rod end removal quick and easy
- Smooth or threaded body in 6-, 7-, and 8-inch lengths—threaded body versions use 2.5-inch springs
- Available in 1/2-inch and 5/8-inch shaft size for different applications



## PRECISION TWIN TUBES

- Exclusive internal design gives consistent fade-free performance in the harshest conditions
- Non-adjustable or single adjustable
- Standard body or small body, smooth or threaded: 6-, 7-, 8-, and 9-inch lengths
- Standard body available in 1/2-inch and 5/8-inch shaft size for different applications



## ALL NEW STEEL BODY PRECISION TWIN TUBES

- All new steel threaded body precision twin tubes
- Same great features as Slade's aluminum versions in a steel threaded body version
- Non-adjustable or single adjustable in 7- and 9-inch lengths
- Shocks can be configured with steel body and aluminum copper colored cap or steel body with black steel cap



## BUMP CONES

- Durable material that won't give up after a couple races
- 2-inch tall cone shape creates a gradual progression of compression force before spiking when used with Slade's cups
- Five stiffnesses to meet the needs of nearly any type of application
- 1/2-inch and 5/8-inch ID versions available

# *PERFORMANCE-DRIVEN* *PASSION-FUELED*



PRI Booth #8227



[ATCtrailers.com](https://ATCtrailers.com)

# WELD RACING INC.

weldracing.com | 800-788-9353



## SOLANA BEADLOCK

- Flow form construction. Forged beadlock ring
- Gloss black milled or gloss machined finish
- Massive list of fitments (five and six lug)
- Optimized brake clearance



## MAGNUM SPRINT

- Forged aluminum construction. 6061 anodized centers. Grade 8 hardware
- Multi-piece construction allows replacing of damaged parts
- Double, single, and non beadlock options available



## ALPHA-1

- Three-piece forged construction. Optimized for weight reduction
- Floating hubless design found on the Delta-1
- Black anodized or polished finish. Forged 6061 beadlock rings
- SFI 15.1 certified or Pro SFI 15.3 version available



## V-SERIES FRONTRUNNER

- Forged 6061 monoblock construction. Optimized for weight reduction
- Black anodized or polished finish. Spindle mount or lug mount available
- SFI 15.2 certified
- Matching rear wheels available in 15 and 16 inches

# Flush Mount & T-handle Caps

Available in  
6-bolt or 12-bolt  
mounting flange

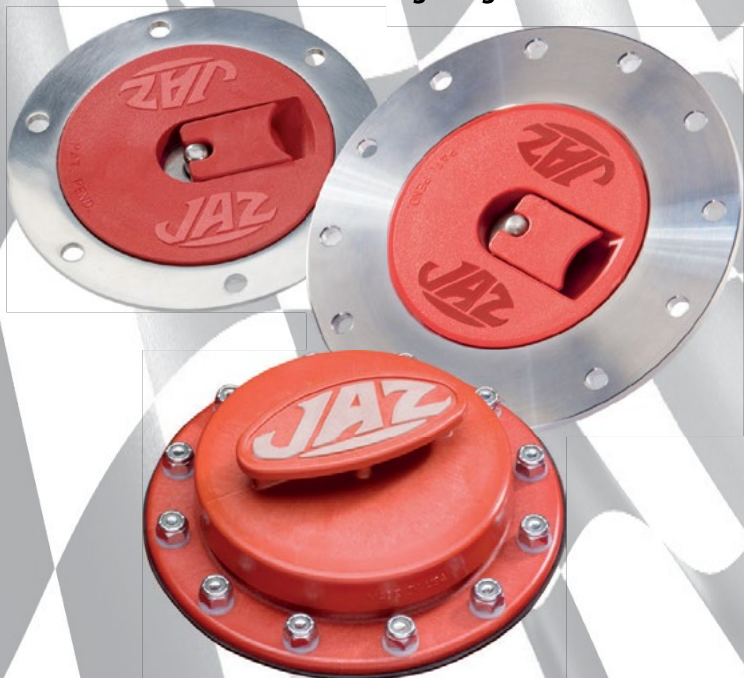

Available in  
6-bolt or 12-bolt  
mounting flange

Cap to filler hose  
adapter included  
(not pictured)

For that perfect  
vintage look!



# Billet Style Caps

Available in  
6-bolt or 12-bolt  
mounting flange



Cap to filler hose  
adapter included  
(not pictured)

# Billet Threaded Caps

Available in 6-bolt or 12-bolt  
mounting flange



CALL FOR FREE CATALOG!



[WWW.JAZPRODUCTS.COM](http://WWW.JAZPRODUCTS.COM)  
800-525-8133  
Mention this ad for special show pricing



### 6XD SEQUENTIAL GEARBOX 6XD SEQUENTIAL GEARBOX

- 6XD sequential transmission  
1,800-plus lb.-ft. rated
- Street and track applications
- 4-, 5-, 6-speed units
- OEM install kits for Viper Gen5; Supra MK4; C5, C6, C7 Corvette; Gen6 Camaro; 4WD packages
- Fits any front-engine rear-wheel-drive build
- NEW 6XD Transaxle unit arriving in 2025 to be strongest

Contact: 770-317-8121  
[6xdgearbox.com](http://6xdgearbox.com)



### ADVANCED CLUTCH TECHNOLOGY 10.5-INCH GM MOD-TWIN CLUTCH

- 10.5-inch Mod-Twin clutch features a modular hub system with spring or solid hubs and Street or 6-Puck race discs
- Its Mono-Drive hub reduces input shaft wear, while the forged aluminum cover enhances pedal feel
- Engineered for 1,496 ft.-lb. of torque at the engine, it supports superchargers, turbochargers, nitrous, and more

Contact: 661-940-7555  
[advancedclutch.com](http://advancedclutch.com)



### AED METAL PRODUCTS FABRICATION METALS & PRODUCTION TUBE BENDING

- Metal supplier of 4130, Docol, stainless, aluminum, and mild steel
- Production tube bending and end forming

Contact: 317-334-0569  
[aedmetals.com](http://aedmetals.com)

# DESIGNED TO OUTPERFORM EXPECTATIONS

## Race Ready.



**92740**  
Complete Arm  
(\*'63-'82 Corvette R or L)

**92025**  
Offset Race Pivot  
w/Delrin Insert

**92006**  
GM 0° Ball Joint  
Plate

**93450**  
6.5" Chromoly  
Cross Shaft

**92055**  
5" Aluminum  
Adjusting Sleeve

SPC knows what it takes when it comes to race-ready adjustable upper control arms and a podium finish. All components are interchangeable and are recommended for circle track, road racing and drag applications. Each arm features adjustments to optimize suspension geometry and a wide selection of chassis options are also available for performance you can feel.

**SPC**  
**PERFORMANCE**  
*Feel The Difference!*

By  Specialty Products Company®  
©2024 Niwot Corp., dba Specialty Products Company®

1.800.525.6505

[specprod.com](http://specprod.com)







**ANDERSON COMPOSITES  
TYPE-CR DRY CARBON  
FIBER HOOD**

- Fits 2015–2020 Ford Shelby GT350 and GT350R only
- Track-day inspired, improved heat extraction design
- Autoclave process with pre-preg 3K, 2x2 twill carbon-fiber cloth
- Center vent measures 20 inches wide by 23 inches long
- Side vents measure 8 inches wide by 16 inches long
- Hand-crafted hood weighs approximately 20.8 pounds, 30% lighter than OEM hood
- Form follows function: reduce weight, increase downforce, improve heat extraction

Contact: 626-333-7024  
andersoncomposites.com



**AURORA BEARING CO.  
ROD ENDS AND SPHERICAL  
BEARINGS**

- Rod ends
- Spherical bearings
- Available in imperial and metric dimensions

Contact: 630-859-2030  
aurorabearing.com



**AUTOTECH DRIVELINE  
CONTINENTAL MOTORSPORTS  
ABS KIT**

- Autotech Driveline is your source for Continental Engineering's Motorsports ABS Kit
- Based on its high-performance MK100, the sophisticated software provides superior braking performance, outperforming its competitors on bumpy courses like the Nürburgring Nordschleife
- Works with a wide range of speed sensors
- Every kit includes diagnostic cable and full software capability

Contact: 949-362-8700  
race-abs.com

STEERING YOU IN THE RIGHT  
**DI-R-E-C-T-I-O-N**

**SELF-POWERED  
TIMING LIGHT**

State of the art  
single wire design  
10 FT LEAD: **FR1010**  
20 FT LEAD: **FR1020**



LEVER HANDLE

250 AMPS  
500 AMPS

**BATTERY  
DISCONNECTS**

With a vehicle vibration  
resistant design, this 500  
amp switch is engineered to  
be light weight for racing.



**UNIVERSAL  
JOINTS**

Strength & Reliability  
derived from  
quality materials



BILLET-JOINT

DOUBLE U-JOINT  
UP TO A 60° ANGLE!

**MANUAL  
RACK & PINION**

PINTO STYLE MANUAL RACK

PN: **FR1501**



LATE MODEL '05-'14 MUSTANG MANUAL RACK

PN: **FR1515**

**THE MICROSTEER**  
ELECTRIC POWER  
ASSISTED STEERING

Can be easily fitted to virtually any vehicle,  
without the need to change steering rack or fit a  
hydraulic system where manual currently exists

PART NUMBER:  
**FR40200**



VISIT OUR WEBSITE: **FLAMINGRIVER.COM** CALL US AT: **800-648-8022**



### **BOKER'S CUSTOM VALVE SHIM STACKS**

- Precisely manufactured to unique customer specifications
- Unsurpassed finishing capabilities meet needs of a wide range of recreational, automotive and industrial suspension applications
- Quantities starting at 100 pieces; available into the millions
- Fast delivery

Contact: 800-927-4377  
[bokers.com](http://bokers.com)



### **BOSCH MOTORSPORT EBS ADAPTED FOR HAND CONTROLS**

- Bosch utilized its existing electronic brake system (EBS) module from the LMDh class and adapted it for Robert Wickens' hand-controlled braking system
- The added technology allows Wickens to have more consistency across the application of brakes, faster response rate, and advanced diagnostics for safety

Contact: 248-876-1000  
[bosch-motorsport.com](http://bosch-motorsport.com)

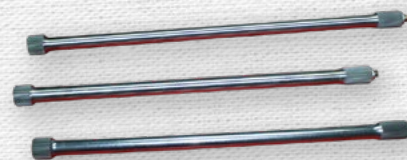

### **BUZZER AXLES BUZZE AXLE**

- These axles come in three lightweight styles for affordable weight savings and increased grip
- LW (lightweight)
- XLW (extra lightweight)
- ULW (ultra lightweight)
- These axles are a true torque-absorbing axle and promote maximum drive on corner exit

Contact: 704-664-8907  
[buzzeracing.com](http://buzzeracing.com)



### ***Diesel Performance Parts***

- Turbo Upgrades and Install Kits
- Intake Kits and Intercooler Pipes
- Down Pipes, Up Pipes and Manifolds
- Pulling Hitches and Sled Stops
- Built Allison Transmissions
- Traction Bar Kits
- Billet Aluminum Wheels
- Modular Steel Work Benches

[WCFab.com](http://WCFab.com) - 630-277-8239



**CECOMP ELECTRONICS**  
**CECOMP DIGITAL PRESSURE GAUGES**

- ±0.25% test gauge accuracy, ±0.1% optional
- Keypad selectable units
- Store up to eight readings in memory
- Memory labels for tire locations
- Vacuum to 5,000 psi ranges
- Made in USA
- Tire pressure gauge: F20BBL100PSIG-M8R-RB

Contact: 847-918-3510  
[cecomp.com](http://cecomp.com)



**CENTERFORCE CLUTCHES**  
**CENTERFORCE LIGHTWEIGHT ALUMINUM FLYWHEELS**

- For GM Gen I small-block, big-block and LS applications
- Constructed of lightweight billet aluminum
- SFI certified
- Replaceable steel friction surface
- Mechanically retained starter ring
- Precision balanced
- Low inertia for quicker revving

Contact: 928-771-8422  
[centerforce.com](http://centerforce.com)



**CHALEW PERFORMANCE**  
**WIDE 5 WHEEL STUDS**

- Manufactured by MSI Racing Products, which offers premium wheel studs and lug nuts for top motorsports and OEM manufacturers
- Made in the USA with the highest quality material
- Available in four lengths: 1.75 inch, 2.00 inch, 2.25 inch, 2.50 inch

Contact: 704-660-1101  
[chalew.com](http://chalew.com)

**FiTech**  
**Fuel Injection**



**ULTRA PORT**  
**LS EFI SYSTEM**



**SUPPORTS UP TO 1000 HP**

- **Most complete kit on the market** with sensors, harness, throttle body, intake manifold, and everything you need.
- **Universal 4-Barrel Design.**
- **The standalone ECU is designed for easy installation, compatible with various timing control setups.**
- **Port Injection to optimize fuel burn and throttle response.**
- **Available for LS1 and LS3 applications**

**SEE US IN BOOTH**  
**#2111**

🌐 [FITECHEFI.COM](http://FITECHEFI.COM)    ✉ [SALES@FITECHEFI.COM](mailto:SALES@FITECHEFI.COM)    ☎ (951) 340-2624



**DIVERSIFIED MACHINE INC., DMI RACING COMPONENTS/BULLDOG QUICK CHANGE REARS**  
**BULLDOG XR420I V2**

- Premier IRS quick-change rearend for drifting and applications requiring independent rear suspension
- Great design produced with the right materials
- Uses track-proven, proprietary seven key factor formula

Contact: 717-397-5347  
[diversifiedracing.com](http://diversifiedracing.com)



**DRIFT LIST**  
**E-BRAKE HANDLE GRIP**

- Direct replacement grip for the Sikky e-brake rubber handle
- Constructed from durable G10 material (also available in wood)
- Features a checkered texture for enhanced grip and control
- Designed for reliability in high-performance drifting
- Ideal upgrade for serious drifters seeking improved style and functionality

Contact: 217-778-3357  
[driftlist.com](http://driftlist.com)



**FRENKIT PERFORMANCE**  
**HIGH TEMPERATURE CALIPER REPAIR KIT**

- Frenkit Performance offers innovative components designed for extreme conditions and performance for your brake calipers, including specific pistons, silicone dust boots, and high performance piston seals
- Developed through extensive research and experience in motorsports, they ensure durability and effectiveness in braking systems for enthusiasts and professionals
- Do not hesitate and enhance your caliper's durability

Contact: +34 948 341 331  
[frenkit.es](http://frenkit.es)



## QUALITY IS LIFE

Daido Metal, est. 1939, is the *world's largest engine bearing* supplier. Daido provides you superior products, technical support, unmatched quality, and consistent machining tolerances.



**EXCLUSIVE ENGINE BEARING  
 SUPPLIER OF ROUSH YATES ENGINES**

**DAIDO METAL USA, INC. | [DMUSA-ORDERS@DAIDOMETAL.COM](mailto:DMUSA-ORDERS@DAIDOMETAL.COM)**  
 BELLEFONTAINE, OHIO | FARMINGTON HILLS, MICHIGAN



**HOOSIER RACING TIRE TRACKATTACK PRO**

- UTQG 200 Extreme Performance Summer tire engineered for both track dominance and street performance
- Adrenaline-fueled acceleration and dynamic braking for responsiveness and handling
- Unrivaled grip using motorsports-proven compounds
- Extra-wide shoulder ribs maximize cornering performance
- Featherlight construction ensures peak responsiveness
- Optimized center rib enhances braking performance

Contact: 574-784-3152  
[hoosiertire.com](http://hoosiertire.com)



**HOWE RACING ENTERPRISES HOWE PRECISION BALL JOINTS**

- Low resistance
- Captured ball for precise front-end alignment
- Large selection of interchangeable stud sizes
- Proprietary process allows the stud to bend while the ball resists wear
- Fewer pieces and no plastic internal parts for superior durability
- Made in the USA

Contact: 989-435-7080  
[howeracing.com](http://howeracing.com)

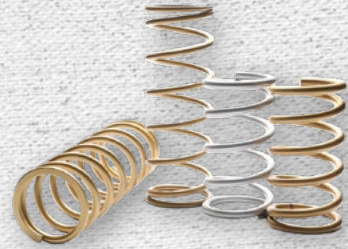

**LANDRUM PERFORMANCE SPRINGS LANDRUM SPRINGS**

- Landrum springs use premium materials and state-of-the-art engineering to produce durable and consistent springs that won't lose free height
- Landrum has close tolerances and tests within 2% of specification
- Proven with a dyno sheet provided with each spring

Contact: 866-703-3154  
[landrumspring.com](http://landrumspring.com)

# ULTRA-LITE INSULATING MAT

**MADE IN USA** PROTECTS FROM THE EXCESSIVE HEAT COMING THRU THE FLOORBOARD

Enter code **PR120** to receive 20% off your order at [ThermoTec.com](http://ThermoTec.com)  
 (800) 274-8437 [www.ThermoTec.com](http://www.ThermoTec.com)

Available at:



### LARSEN RACING PRODUCTS PLATINUM TRACK DIFFERENTIALS

- Quick-change, Ford 9-inch torque sensing all gear driven differentials
- Lock resistant brake valves (LBS), brake recirculator

Contact: 707-765-6961

[larsenracingproducts.com](http://larsenracingproducts.com)

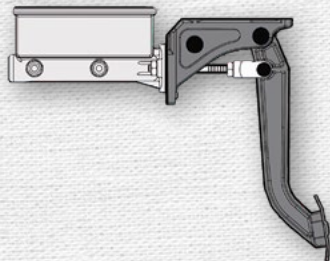

### MANUALBRAKES.COM MANUAL BRAKE CONVERSIONS

- GM A-Body
- GM B-Body
- GM F-Body
- GM G-Body
- GM H-Body
- GM X-Body
- C10
- S10
- LUV

Contact: 832-264-5566

[manualbrakes.com](http://manualbrakes.com)



### MUSTANGSTEVE 1964.5-1973 FORD MUSTANG TO COBRA DISC BRAKE CONVERSION

- Front Cobra brake mounting kit
- Designed for 1964.5-1973 Ford Mustang/Mercury Cougar, 1970-1977 Ford Maverick/Mercury Comet
- Adapts 1994-2004 SN95 Cobra 13-inch front disc brakes (calipers and rotors)
- 17-inch wheels required for clearance
- Uses drum brake hub
- Fasteners included

Contact: 817-501-4538

[mustangsteve.com](http://mustangsteve.com)

## HORSE POWERTRAIN

# THE FASTEST ENGINE AT PIKES PEAK 2024

With numerous FIA TCR World Tour championship titles, millions of Aurobay powertrains in cars on the roads, and over 40 years of experience perfecting our craft, our engines are Tuned to Perform.



See us



in action



**PERFORMANCE DRIVELINE ENGINEERING DRIVESHAFT**

- Custom built

Contact: 248-761-3247  
[pdedriveshafts.com](http://pdedriveshafts.com)



**PERFORMANCE ENGINEERING & MANUFACTURING QUICK-CHANGE REAREND METRIC TOP MOUNT**

- New, updated
- Enables placement of quick-change rearend in 1978-1988 GM mid-size metric chassis
- Built with 4 degrees down pinion angle
- Polyurethane top bushings installed

Contact: 636-629-6200  
[pemracing.com](http://pemracing.com)



**PUREFORGE BRAKES ATOMICFORGED BRAKE KITS**

- Patented treatment process
- Create durable, hardened brake rotor surface
- Pads last longer
- Reduce brake dust
- Reduce brake fade

Contact: 248-481-7096  
[www.pureforge.com](http://www.pureforge.com)

**THE BEST GIFT UNDER THE TREE**

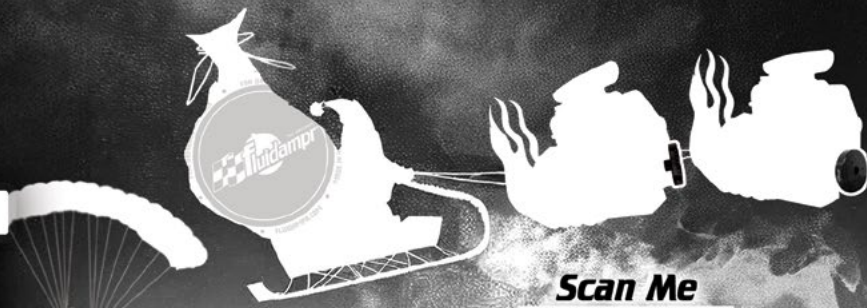

To Find One Of Our Great Dealers!



Performance Dampers for Gas & Diesel Engines  
 Made In the USA!





### RAYBESTOS POWERTRAIN TH400 GEN 2 BLUE FRICTION CLUTCH PACK

- Raybestos Powertrain GM TH400 Clutch Pack Module GEN 2 Blue Plate Special
- RCPBP-03 features three Intermediate GEN 2 Blue Race Product, 10 Forward Direct GEN 2 Blue Race Product Friction Clutch Plates

Contact: 765-359-2554

[raybestospowertrain.com](http://raybestospowertrain.com)



### SONNAX TH400 SMART-TECH DRUM MODULE

- Increase wheel horsepower, improve acceleration and reduce shock on shifts while ramping up durability and safety
- All-in-one kit upgrades forward and direct drums, plus everything else from intermediate sprag to back of the pump
- Unique design improves efficiency without reducing capacity
- Easy to assemble and install

Contact: 802-463-9722

[sonnax.com](http://sonnax.com)



### SWIFT SPRINGS USA 8-INCH BARREL SPRINGS

- Brand new line
- Made from proprietary HS5.TW material
- Available in five rates at 8-inch length with a 2.5-inch inner diameter
- Barrel design with fewer coils
- Linear through stroke
- Excellent for stacking

Contact: 909-393-8623

[swiftsprings.com](http://swiftsprings.com)

#### MANDREL BENDS



#### MERGE COLLECTORS



#### HEADERS



#### CUSTOM FAB



## CNC MACHINED FLANGES

VIEW OUR  
CATALOG ONLINE



### Race Engines

From 600cc - 1015cid

- Domestic • Late Model
- Import • Vintage

3/8" & 1/2" Thick Stainless,  
Carbon Steel & Titanium

# SPD

SPECIALTY  
PRODUCTS  
DESIGN INC.

888.778.3312

[www.spdexhaust.com](http://www.spdexhaust.com)

Exhaust Engineering Excellence Since 1969





**TILTON ENGINEERING**  
**OT-215 8.5-INCH METALLIC CLUTCH-FLYWHEEL KITS**

- Designed for drifting, track day, pro touring, off-road buggy applications
- Available in three-disc (1,290 lb.-ft.) and four-disc (1,920 lb.-ft.) configurations for popular Chevy, Ford, and Toyota engine applications
- Include clutch, billet chromoly steel flywheel, clutch bolt kit, and flywheel bolt kit

Contact: 805-688-2353 (113)  
[tiltonracing.com](http://tiltonracing.com)

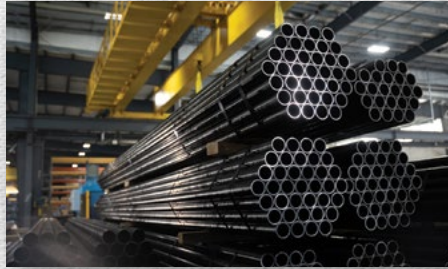

**WEBCO INDUSTRIES**  
**FINISHLINE CHASSIS TUBING**

- Webco's tubing meets the exacting mechanical, dimensional, and finish properties today's chassis builders and drivers require
- Available in chromoly (CrMo), Drawn Over Mandrel (DOM), and as Centerless Ground (CG)
- Available in 0.049" – 3.000" OD and .065" – .375" wall for chassis, roll cages, and other critical components to give drivers the competitive edge and a product they trust

Contact: 918-245-2211  
[webcotube.com](http://webcotube.com)

CONNECT



PRISHOW.COM/SOCIAL



Find yours online!



You Rings engineered for UEM Pistons!  
**WANT RINGS with THAT?**



UNITED ENGINE & MACHINE  
1.800.648.7970 | [www.uempistons.com](http://www.uempistons.com)

SECTION

3

# RACING COMPONENTS, ACCESSORIES & SERVICES

Outside of the engine and beyond building the race car, are the ancillary products and services that fall under this category. Whether looking for a new supplier of safety gear, lubricants, or trailers, or seeking expanded options in electronics or pit equipment, these suppliers can help your operation complete your customers' racing programs.

# OUR PERFORMANCE WILL MOVE YOU

## Superglide - Super Hydra 400 - Super 80 Cases

- PG1500 - 1-Piece Powerglide Case
- PG1500R - 1-Piece Powerglide Case (Roller Bearing)
- PG2000 - Superglide 2-Piece Transmission Case
- PG2000R - Superglide 2-Piece Transmission Case (Roller Bearing)
- PG2000-400(B/R) - Superglide Transmission Case for TH400 Output
- SH400-DRAG - Super Hydra 400® Transmission Drag Case
- SH400-OFF - Super Hydra 400® Transmission Off-Road Case
- S80 - Super 80® Transmission Case

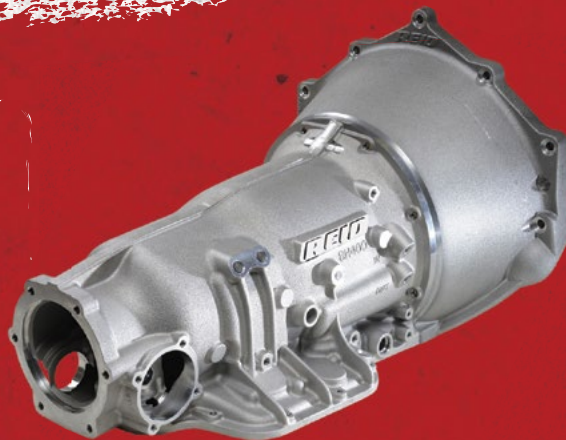

## OFF-ROAD STEERING KNUCKLES

- Jeep JL
- Jeep JK
- Dana 44/Dana 60
- Super Kingpin



## SFI 30.1 BELLHOUSINGS

- BH001 - GM
- BH005 - GM - Lockup Converters
- BH010 - Ford - Small Block
- BH020 - Ford - Big Block
- BH030 - Buick Oldsmobile Pontiac
- BH040 - Mopar - Big Block
- BH050 - Ford - Modular/Coyote
- BH060 - Mopar - Small Block & Gen 3 Hemi

GM — FORD — MOPAR

## PERFORMANCE TORQUE CONVERTERS



WWW.CIRCLEDSPECIALTIES.COM  
WWW.REIDRACING.COM

(713) 895-8834

**CIRCLE D**  
SPECIALTIES

**REID**  
RACING, INC

# ASHCROFT INC.

ashcroft.com | 800-328-8258

**ASHCROFT**  
Trust the shield.®



## S1 PRESSURE TRANSDUCER

- Designed for high-volume manufacturing with high-quality, low cost and quick lead times
- All stainless-steel, thin-film pressure CVD-based sensor technology for exceptional cycle life and repeatability
- Outstanding shock and vibration resistance
- IP65 and/or IP67 levels of ingress protection



## G2 AND G3 PRESSURE TRANSDUCERS

- G2: Field-proven sensor; all stainless-steel wetted materials provide excellent overpressure capability and durability
- G3: All 316L stainless steel wetted materials for installations in pressures as low as 100 in. H2O
- Both G2 and G3 highly configurable with wide selection of pressure connections, outputs, and electrical terminations



## GV PRESSURE TRANSDUCER

- All-welded sensor and pressure connection designed for high vibration applications
- Field-proven polysilicon thin-film pressure sensor provides excellent overpressure capability and outstanding durability despite substantial shock and vibration
- Highly configurable with wide selection of pressure connections and electrical terminations



## DG25 DIGITAL PRESSURE GAUGE

- All-welded sensor and pressure connection provide reliable vehicle support in pit lane
- Available in a wide variety of pressure ranges, connections and optional features, including backlit display and rubber protection boot
- Provides menu-driven features including unit select, min/max hold, and dampening

# COOL RACING PARTS

coolracingparts.com | 239-415-2445



## CARBURETOR SLIP COVER

- Cools and condenses the air-fuel mixture to enhance performance and helps prevent heat soak
- Fits any single carburetor on a low- or high-rise intake manifold
- Acts like a sponge when used with ice, preventing water from dripping into the engine
- Reaches near-freezing temperatures using a simple activation process



## SUPERCHARGER COOLING PAD

- Cools and condenses air-fuel mixture, enhancing horsepower and torque for improved performance
- Helps prevent overheating caused by heat soak
- Compatible with both factory stock and aftermarket superchargers
- Activate with water, then store in ice chest or refrigerator; reaches near-freezing temperatures
- Unlike ice bags, it absorbs water, keeping the area clean



## DYNO BLANKET

- Improves performance by maintaining stable and manageable engine temperatures

- Absorbs and removes heat from the engine and its components
- Features evaporative cooling technology that accelerates temperature drop
- Protects engine components against power-robbing heat soak
- Reduces time between dyno pulls
- Optimizes tuning for peak horsepower gains
- Cools faster than ice bags



## EFI INTAKE PIPE COOLER

- Cools and condenses airflow, increasing horsepower and torque, and maintaining consistent temperatures
- Helps prevent heat soak by lowering intake airflow temperatures for better recovery
- Parts can reach near-freezing temperatures in just minutes
- Ideal for normally aspirated, turbocharged, or supercharged engines
- Outside diameter options available for 2-, 3-, and 4-inch pipes

# KIRKEY RACING FABRICATION

kirkeyracing.com | 800-363-4885



## 85 SERIES INTERMEDIATE 10° LAYBACK CONTAINMENT SEAT KIT

- New for 2025
- Unique adjustable design eliminates the need for a custom seat, saving hundreds of dollars
- Three-piece design gives 3 1/2" vertical adjustment. 2-1/2" in

torso, 1" for head restraint

- Designed for: Limited Sprint Cars, Northeast Dirt Modifieds
- 10° layback
- Available in 14" through 17" hip widths



## 86 SERIES INTERMEDIATE 20° LAYBACK CONTAINMENT SEAT KIT

- New for 2025
- Unique adjustable design eliminates the need for a custom seat, saving hundreds of dollars

• Three-piece design

gives 3-1/2" vertical adjustment. 2-1/2" in torso, 1" for head restraint

- Designed for: Dirt Late Models, Asphalt Late Models, Crate Late Models, Midwest Modifieds, Street Stock
- 20° layback
- Available in 14" through 18.5" hip widths



## 35 SERIES CHILD ADJUSTABLE CONTAINMENT SEAT KIT

- Unique adjustable design allows seat to grow with your young driver
- Three-piece design gives 3-1/2" vertical adjustment. 2-1/2" in torso, 1" for head restraint

- Designed for: Caged Karts, Dwarfs, Legends, Mod Lites, Street Stocks, Tobias Slingshots
- 18° layback
- Available in three sizes: 10", 12", 14"
- Foam insert kit included to reduce width up to 1" for smaller drivers

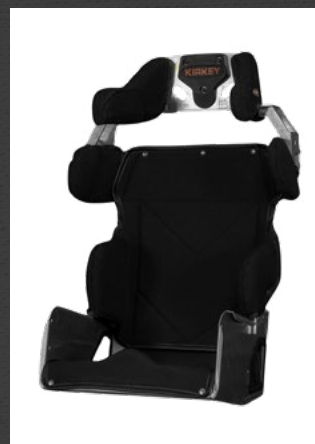

## 83 SERIES STANDARD 10° LAYBACK CONTAINMENT SEAT KIT

- This popular entry-level containment is now available in a 10° layback
- Three-piece design gives 3-1/4" vertical adjustment. 2-1/2"

in torso, 3/4" for head restraint

- Designed for low-horsepower vehicles with limited space
- Available in 14" through 18.5" hip widths

# LAT RACING OILS

latracingoils.com | 714-341-1241



## PRO LITE ATF GALLON

- Pro Lite ATF is a 20WT automatic transmission fluid
- Great for bracket racing, naturally aspirated, and nitrous engines
- Extreme temperature control
- Faster lock-ups, smoother shifts, and improved elapsed times
- Exclusive PCE Technology reduces wear and offers longer life on all internal parts



## PRO ATF GALLON

- Pro ATF is a 30WT automatic transmission fluid
- Great for Top Dragsters, turbo cars, Pro Mods, and other high-output cars
- Extreme temperature control
- Faster lock-ups, smoother shifts, and improved elapsed times
- Exclusive PCE Technology reduces wear and offers longer life on all internal parts



## PRO MAX ATF GALLON

- Pro Max ATF is a 50WT automatic transmission fluid
- Great for when a more aggressive fluid is needed for higher horsepower applications and tighten loose converters
- Extreme temperature control
- Faster lock-ups, smoother shifts, and improved elapsed times
- Exclusive PCE Technology reduces wear and offers longer life on all internal parts



## PRO X ATF GALLON

- Pro X ATF is a 60WT automatic transmission fluid
- LAT's most advanced ATF developed for the extreme conditions for classes like X275 and Pro Mod and improved positive clutch engagement
- Extreme temperature control
- Faster lock-ups, smoother shifts, improved elapsed times

# MAXIMA RACING OILS

maximausa.com | 619-449-5000



## STEP 1: ASSEMBLY LUBE

- Lubricant designed to form a durable protective film on moving components
- Formulated with 2X Zinc anti-wear system that activates at both high and low temperatures
- Prevents metal-to-metal contact after startup
- Non-foaming formulation easily dissolves into both mineral and synthetic oils



## STEP 2: ASSEMBLY GREASE

- High-performance assembly grease that excels in a multitude of heavy- and light-duty applications
- Unique calcium sulfonate complex soap thickener combines with a proprietary additive system to deliver thermal stability and extreme pressure performance
- Oil-soluble formulation won't clog filters and provides protection against corrosion, water washout, and wear



## STEP 3: PERFORMANCE BREAK-IN OIL

- Mineral-based engine oil specifically formulated for breaking in engines with flat tappet camshafts, roller elements, and where maximum anti-wear performance is needed
- High ZDDP formulation combines the highest quality mineral base stocks with a shear-stable polymer system to provide fast and effective ring seal
- Proprietary additive system utilizes a complex, low temperature activating 2X Zinc system that ensures immediate and lasting protection



## STEP 4: CHOOSE YOUR LEVEL OF PERFORMANCE

- Mineral-based engine oil developed formulation utilizes a 2X Zinc system combined with stay-in-place chemistry for protection during every run
- Semi-synthetic, ester-based engine oil designed to ensure optimum protection and peak performance for race and hot rod engines
- Full-synthetic, triple ester racing engine oil designed to ensure maximum performance while providing maximum protection under the most severe conditions



# PERFORMANCE PLUS GLOBAL LOGISTICS

pplusglobal.com | 636-946-7587



## LOGISTIC SOLUTIONS

- Official logistics partner of the performance industry
- Performance Plus manages the logistics needs of customers with the highest quality service at competitive prices
- Performance Plus's mission is to exceed customer expectations by providing 'Best in Class' custom solutions
- Performance Plus provides each customer with a dedicated professional with experience in performance and transportation

# SCHAEFFER MANUFACTURING CO.

[schaefferoil.com](http://schaefferoil.com) | 314-865-4100



## MICRO MOLY RACING OIL 10W-30

- Resists separating from alcohol-based fuels
- Extra zinc to protect flat tappet cam engines and other components from wear
- Extra protection for when engines are operating at higher temperatures. Keeps engines clean from harmful debris and buildup
- Reduces oil consumption



## MICRO MOLY RACING OIL SAE 70

- Resists separating from alcohol-based fuels
- Extra zinc to protect flat tappet cam engines and other components from wear
- Extra protection for when engines are operating at higher temperatures. Keeps engines clean from harmful debris and buildup
- Reduces oil consumption



## PENETRO 90 PENETRATING OIL

- Excellent on heim joints, wheel studs, and weight jack bolts that have become difficult to operate
- Prevents thread stripping and busts through rust. Protects against corrosion, rust, and abrasive particles
- Frees stuck and rusted parts but doesn't affect seal materials or coatings



## SUPREME GEAR LUBE 75W-90

- Reduces operating temperatures. Enhanced thermal and oxidative stability and durability
- Excellent extreme pressure properties to protect against wear. Enhanced gear, bearing, and seal cleanliness
- Compatibility with all types of seals

# THERMO TEC AUTOMOTIVE

thermotec.com | 800-274-8437



## ADHESIVE-BACKED HEAT BARRIER

- Shields components from radiant heat with its aluminized finish and woven silica material
- Handles up to 300°F of direct heat and 2000°F of radiant heat
- Easy to apply on any surface or wrap around hoses and wires for a professional look



## ULTRA-LITE INSULATING MAT

- Reduces intense heat for race car drivers
- Utilizes cutting-edge materials and Thermal Conduction Technology (TCT)
- Reflects and disperses heat with a highly textured aluminum composite surface
- High-temp synthetic felt center insulates against radiant heat
- Keeps floorboards cooler and more comfortable in extreme conditions



## EXPRESS SLEEVE

- Ultimate solution for wire, hose, and cable protection
- With a hook-and-loop closure, it's easy to apply
- Combining high-temperature insulation with a reflective Mylar foil, it reflects over 90% of heat up to 2000°F
- Available in various sizes and lengths
- Made in the USA



## EXHAUST WRAP

- Experience more horsepower and reduced under-hood temperatures
- Developed over 30 years ago, it maintains hotter exhaust gases for faster exit and increased scavenging
- Withstands up to 2000°F, asbestos-free, and won't over-insulate thanks to Thermal Conduction Technology (TCT) coating, ensuring optimal heat control

# WIELAND

wieland-metalservices.com | 708-385-7000

# wieland

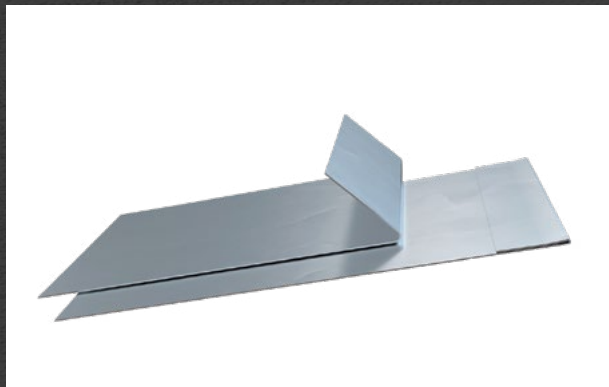

## ALUMINUM SHEETS FOR RACE SEATS AND SPOILERS

- Wieland aluminum sheets are bendable, durable, and rust resistant
- 5052 aluminum provides extra strength and safety
- Ideal for shaping racing seats and spoilers

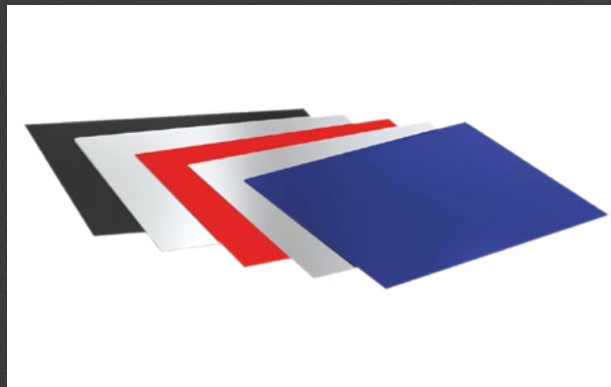

## PAINTED ALUMINUM SHEET AND COIL FOR RACE CAR BODIES

- Available in 40-plus colors
- Most popular: Ultra White, Black Gloss, and Red. Exotic collection includes Extreme Green, Bright Orange, Power Purple, and Electric Pink
- Stocked in gauges 0.020"–0.080"

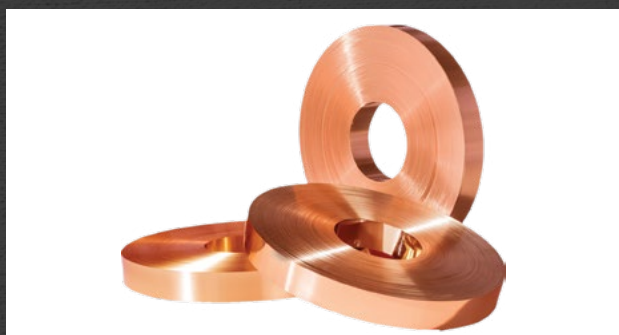

## COPPER SHEETS AND COIL FOR RADIATOR STRIP, GASKETS, AND POWER ELECTRONICS

- Wieland stocks a wide variety of copper and copper related alloys
- Offers increased strength and longevity in performance vehicles
- Stocked in gauges 0.0005"–0.25"



## COPPER ROD AND TUBE FOR BEARINGS AND BUSHINGS

- Wieland rod and tube is available in high-performance alloys such as C63000, C67300, ToughMet 3, and more
- Provides wear resistance, increases power, and features anti-galling properties
- Stocked in a wide range of tempers and diameters



**ALTRONICS**  
**PERFORMAIRE PRO WEATHER SYSTEM**

- Unmatched weather accuracy
- Proprietary performance and air density calculations
- ET-throttle stop plate jetting predictions
- Oxygen and water content measuring
- Remote display capability
- Easy track setup and storage
- Integrates with included racing logbook software
- Weather and wind tracking
- Event and run storage
- Weather/prediction paging and text messaging

Contact: 847-923-0002  
[altronicsinc.com](http://altronicsinc.com)



**AUTOROD CORPORATION**  
**ARC - TSM-1**

- Designed for drag racing and drag-and-drive race cars that drive on the street and track
- Completely standalone directional controller for all vehicles
- Provides turn signals, brake lights, and hazards
- Includes printed wire and the necessary switches

Contact: 732-851-5095  
[autorod.net](http://autorod.net)



**AVIORACE USA CORP.**  
**BIOMETRICS CONTROL UNIT (BCU)**

- Introduced at PRI Show
- The BCU extracts real-time biometric data from sensors to monitor driver's physical performances
- It operates on BLE 5.2 using the heart rate monitor (HRM) profile and transmits data over CAN 2.0 with a configurable baud rate

Contact: 704-402-7802  
[aviorace.it/en](http://aviorace.it/en)



CHECK OUT THE...  
**2024 INNOVATIONS**



**LUBRICANTS**



**GASKET MAKERS**



**THREAD COMPOUNDS**



**STOP LEAKS**



**CLEANERS**



### THE BANGSHIFT BILLY THE BANGSHIFT BILLY BUTTON

- Wireless buttons to replace wired steering wheel buttons

Contact: 720-232-7189  
[bangshiftbilly.com](http://bangshiftbilly.com)



### BOTELER RACING OPERATIONS BACKLITE AUTOMOTIVE SIGNS

- Backlit signs controlled with a user-friendly remote
- Seamlessly fine-tune light including an elegant classic white light
- Variety of lighting modes, such as animated flashing
- 20 background colors
- Color-fading mode
- Solid aluminum frame with meticulously screen-printed graphics
- Utilizes long-lasting replaceable LED light, rated for 50,000 hours

Contact: 410-876-6851  
[botelerracing.com](http://botelerracing.com)



[www.bryke.com](http://www.bryke.com)  
Your Race Parts Warehouse

### BRYKE RACING CIRCLE TRACK PARTS

- Provides next-day delivery of circle track parts
- To Arkansas, Oklahoma, most of Missouri, and half of Kansas

Contact: 479-824-0966  
[bryke.com](http://bryke.com)

BOOTH  
2441

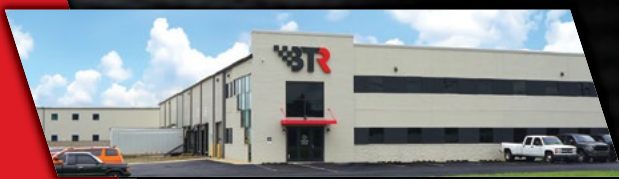

# BTR



## WHERE *PASSION* FUELS INNOVATION

888-959-8865 • [BRIANTOOLEYRACING.COM](http://BRIANTOOLEYRACING.COM) • BARDSTOWN KY



**BULLY DOG TECHNOLOGIES**  
**40475PG/40475PD**

- 2021–2023 Ford F-150 (Excludes 2023 2.7L and 3.5L)
- 2020–2021 Ford F-250 and F-350 Powerstroke
- Preload and custom tunes
- No need to remove the stock ECU
- Monitor gauges on a customizable display
- Bundle includes Ford Unlock cable

Contact: 386-968-1337  
[bullydog.com](http://bullydog.com)



**CAPITOL RENEGADE**  
**RENEGADE PETERBILT**  
**MOTORCOACH**

- 2025 Renegade 45-foot bunk model/2 full bath motorcoach mid entry
- 4-point auto leveling system
- Side swing power locking baggage doors
- Keyless entry; undercoating; docking lights
- 20-mil Tempcoat walls, ceiling, and floor
- 40,000-lb. hitch with 30,000-lb. insert with 2 5/16-inch ball
- Bed slide-out, bedroom closet/bunk slide-out, 12-foot living quarters slide-out
- Full-length power awning

Contact: 301-474-6800  
[capitolrenegade.com](http://capitolrenegade.com)



**CENTRAL PETROLEUM**  
**CEN-PE-CO LUBRICANTS**

- Heavy-duty oils and lubricants
- Gear lubricants
- Greases
- High-performance fuel additives for gasoline and diesel fuels
- Pulling, track, and race-proven extreme protection engine oils

Contact: 216-521-6630  
[cenpeco.com](http://cenpeco.com)

**A-Arms, Radius Rods, Doors,  
Rock Sliders, Tree Kickers,  
Bumpers, Cages and More**



[wcfab.com](http://wcfab.com) - [sales@wcfab.com](mailto:sales@wcfab.com) - 630-277-8239



**COMPUTECH SYSTEMS  
RACEAIR CLOUD WITH  
RACEBASE ET PREDICTION  
AND LOGBOOK SOFTWARE**

- RaceAir Cloud is a racing weather station used from pro to sportsman ranks
- Paired with the powerful RaceBase drag racing logbook program, the easily customizable ET dial-in prediction gives any bracket racer an edge
- Tune up, run completion, maintenance, graphing, and so much more

Contact: 301-884-5712  
[computech.com](http://computech.com)



**D-A LUBRICANT CO.  
PENNGRADE 1 20W-50  
QUART**

- Designed specifically for racing, classic, vintage, hot rod, and muscle car engines
- 5-quart jug is less expensive than buying five single quarts
- One convenient pour from one container instead of five containers
- Better inventory control
- Better environmental footprint due to less waste

Contact: 317-923-5321  
[penngrade1.com](http://penngrade1.com)



**ECUMASTER USA  
ECUMASTER GDI DRIVER**

- The ECUMaster GDI Driver is a powerful module designed for precise control of gasoline direct injection systems
- It supports up to eight injectors and two high-pressure pumps, integrates with up to four SENT devices, and works with EMU PRO and other ECUs, enhancing engine performance and efficiency in motorsport applications

Contact: 817-523-9947  
[ecumasterusa.com](http://ecumasterusa.com)



SUSPENSION SYSTEMS

PERFORMANCE UPGRADES

BOOST SOLUTIONS



STABBER.COM



Instagram.com/  
STABBERautoparts



Facebook.com/  
STABBERautoparts

✉ **EMAIL** [sales@STABBER.com](mailto:sales@STABBER.com)

☎ **PHONE** (1) 407-556-3744

📍 **ADDRESS** 1500 Tileston Rd. Unit # 201 Saint Cloud, FL 34771, United States

**BOOTH #2604**

🌐 **WEBSITE** [www.STABBER.com](http://www.STABBER.com)



Your preferred  
engineering  
design partner.

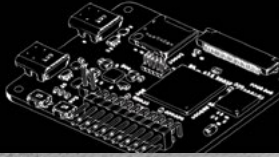

**EVERYDAY DEV  
PRODUCT DESIGN SERVICES**

- Turnkey electrical product development
- Firmware, software, electrical engineering
- Design audits
- Manufacturing support
- Regulatory compliance
- Commercialization

Contact: 720-434-0380  
[everydaydev.io](http://everydaydev.io)



**EVOLUTION MEASUREMENT  
EVOScann**

- Small and lightweight pressure scanners available
- High accuracy multi-channel pressure measurement
- Absolute and differential versions
- Lightweight, carbon fiber-reinforced construction
- Integral microprocessors
- Direct digital output CANbus communications
- Comprehensive range of installation accessories

Contact: +44 (0) 7752238556  
[evolutionmeasurement.com](http://evolutionmeasurement.com)



**FERTAN  
FERTAN RUST CONVERTER**

- Dual-action rust removal and protection
- Converts rust and provides zinc protection in one step
- Easy application: Apply with a brush, roller, or spray on wet or dry surfaces
- Long-lasting protection: Prevents rust for up to six months
- Safe and eco-friendly: Water-based and non-flammable

Contact: 305-614-1140  
[fertanusa.com](http://fertanusa.com)



SEE US  
AT PRI BOOTH  
#5337



**NEW PERFORMANCE CYLINDER HEADS & KITS**



17-125041  
LS3 CNC Stage 3



17-121231  
LS1 CNC Stage 2



17-125551  
LS7 CNC Stage 3

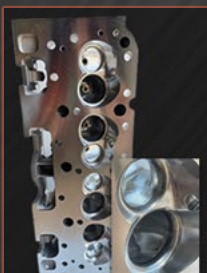

17-120011  
SBC CNC Stage 3



Small Block & LS

**CNC Machined in the USA**

[QualCast.com](http://QualCast.com)



**615-777-3863**



### FLAMING RIVER INDUSTRIES THE BIG SWITCH 500 WITH LED

- LED indicator compatible with 12-volt, 16-volt and 24-volt systems
- 500-amp continuous rating
- Silver pads and terminals and innovative glass-filled nylon material
- Sealed waterproof and corrosion-resistant design
- Made in the USA

Contact: 800-648-8022  
[flamingriver.com](http://flamingriver.com)

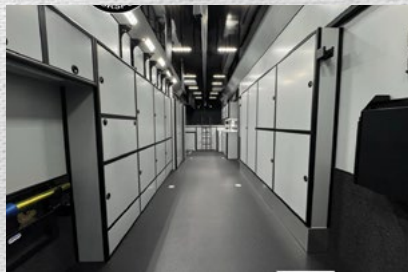

### FLYING A MOTORSPORTS FLYING A DESIGNED INTECH RACE TRAILER

- Fully customizable
- Race ready for drag racing, dirt track racing, sports car, and hot rods
- All aluminum construction
- Custom options for every budget
- Leading the motorsports transportation industry since 1988

Contact: 800-222-4004  
[flyingamotorsports.com](http://flyingamotorsports.com)



### GASTOPS METALSCAN MODEL MS4110

- Online oil debris monitoring systems designed to detect the passage of wear metal particles in lube oil lines
- Systems, which can be used in any pipe-flow situation, are particularly suited to equipment applications where detecting metallic debris in the lubrication oil can provide early indication of component wear/damage
- For over 25 years, MetalSCAN has been a standard engine/drivetrain online detection technology on dynos/test stands in motorsports applications, including most of the top manufacturers in IndyCar and Formula 1

Contact: 613-744-3530  
[gastops.com](http://gastops.com)

**ARE DRY SUMP SYSTEMS**  
Products engineered  
with a passion

9 VARIETIES OF LS-1-7 DRY SUMPS  
OVER 2400 SOLD!



1005M

1009

GTM

OVER 60 VARIETIES OF CAST ALLOY CNC-MACHINED DRY SUMPS

SUBARU KITS

LS7 STAGE II

HONDA KITS



Cast alloy-CNC Machined DRY SUMP Pans - including  
Chevy . . . LS 1-7, LT, SBC, BBC, Chevy II, GEN 7, ECOTEC  
Ford . . . 4CYL, ZETEC, DURATEC, FF, V6, V8, MODULAR  
Alfa, BMW, Buick, Rover, Deutz, EVO, Honda, Mazda, Subaru, Toyota,  
VM Motor and more . . .  
Dry Sump Pumps, Tanks, Filters, Drives, ETC.

PRI BOOTH 1351  
RACE RETRO UK STAND 2-304

**SPINTRIC**  
SPINTRIC TECHNOLOGIES, INC.  
WWW.SPINTRIC.COM 916-652-5282



NEW! Filter Adapter  
w/Adjustable Oil Pressure



CNC DRY SUMP TANKS

CENTRIPETAL AIR/OIL SEPARATOR FOR  
DRY SUMP SYSTEMS - TOTALLY PASSIVE

3 FLOW  
RATES



6 PATENTS!



SPINTRIC "AXIAL FLOW"

"One of the most exciting  
developments uncovered in research . . .  
The new passive Air/Oil Separator . . .  
Providing a double benefit to overall oil system . . ."  
David Cooper - Race Engine Technology

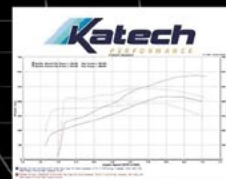

DEAERATION GRAPH

EVERYTHING DRY SUMP!!

"PRODUCTS ENGINEERED WITH A PASSION"

[www.DRYSUMP.com](http://www.DRYSUMP.com)

916-652-5282

[www.SPINTRIC.com](http://www.SPINTRIC.com)



**G-FORCE RACING GEAR  
UTV BELT**

- G-FORCE Racing Gear is proud to announce its entry into the UTV market with its new line of competition UTV Belts
- Contact G-FORCE Racing Gear for more details

Contact: 770-998-8855  
[gforce.com](http://gforce.com)



**HOT SHOT'S SECRET  
ADRENALINE ASSEMBLY  
LUBRICANT**

- Formulated to blend with 100% of break-in oils
- Dry-start protection with over 2,000 PPM of zinc
- Long-lasting corrosion resistance (RATED 1A – D130 test)
- Strong tacky adherence
- 27% better wear protection than leading competitor (ASTM D-4172B testing)
- Complete solubility in engine oil
- Works with all camshaft types

Contact: 800-341-6516  
[hotshotsecret.com](http://hotshotsecret.com)

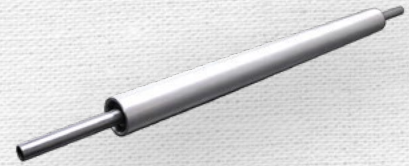

**IDIDIT  
UNIVERSAL PRO-FAB  
STEERING COLUMN**

- Designed for drag, autocross, road course, and off-road racing applications
- Ultra-light aluminum tubing
- Less than 3 pounds
- No mounts for universal fit
- Customizable in length for driver fit
- Pairs perfectly with IDIDIT lightweight, Push to Connect Quick Release Steering Hub

Contact: 517-424-0577  
[ididit.com](http://ididit.com)



**Trust Northern to Keep  
Things Cool While You're  
Heating Up the Track!**

Whatever your race application needs, Northern is up for the cooling challenge! Whether it's circle track, dirt, off-road, or drag racing, we've got high quality radiators, fans, shrouds, and more to help keep your temperature in check so you can do what you do best.

**Need help finding the right products to fit your application?**  
Give us a call and let our knowledgeable customer service staff guide you to the right products to meet your cooling demands.

**Call or Visit Us Online Today!**

1-800-328-8900 • [www.NorthernRadiator.com](http://www.NorthernRadiator.com)



**INEARZ SPORT  
UH-1 MONO CUSTOM-FIT RACE  
EARPHONE**

- Custom-fit and low-profile for under helmet use
- Available in durable acrylic or soft silicone
- Digitally manufactured for improved fit and comfort

Contact: 407-339-2422  
[inearzsport.com](http://inearzsport.com)



**INTECH TRAILERS  
LITE SERIES TRAILERS**

- Affordable complement to InTech's premium custom trailers
- Quality and value
- All-new increased options
- High InTech standards at a more accessible price point

Contact: 574-773-9536  
[intech.com/motorsport-trailers/lite](http://intech.com/motorsport-trailers/lite)



**JASON DIETSCH TRAILER SALES  
UAT ALUMINUM STACKER**

- Industry-leading aluminum X-frame
- Available in two- and three-car models + golf cart
- Available in TAG and gooseneck
- Stinger lift
- Built-to-order trailers with options that United Trailers is known for, including premium jump door, generator and generator-prep packages, dragster lifts, and car-weight-rated loft

Contact: 419-298-0777  
[jasondietschtrailersales.com](http://jasondietschtrailersales.com)

# RELEASE THE POWER OF FR3 FRICTION REDUCER INTO YOUR ENGINE

**5% INCREASE**

IN FUEL ECONOMY  
*(verified by 3rd party ASTM testing)*

**5% INCREASE**

IN HORSEPOWER  
*(verified by 3rd party ASTM testing)*

**REDUCES**

OIL OPERATING TEMPERATURE

**REDUCES**

ENGINE WEAR UP TO 43%  
*(verified by 3rd party ASTM testing)*

**RESTORES**

LOST COMPRESSION

**REDUCES**

LIFTER & VALVE NOISE

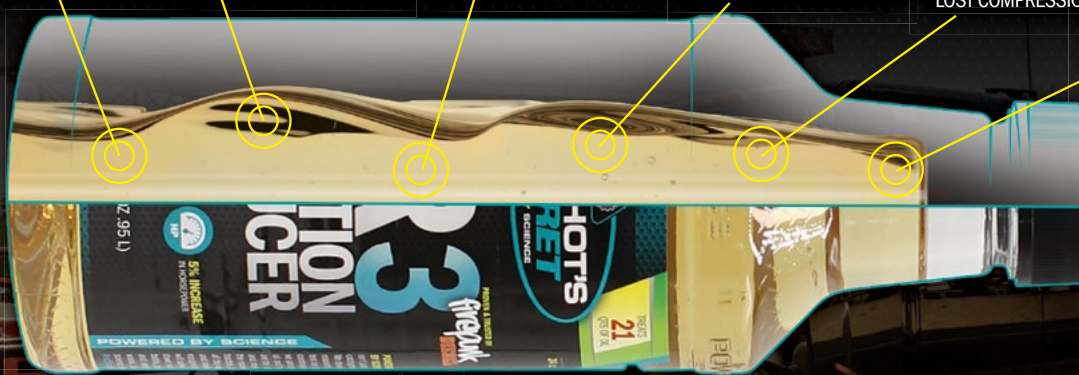

HotShotSecret.com  
800.341.6516



**JAZ PRODUCTS**  
**BILLET THREADED CAPS**

- Billet aluminum threaded fuel cap
- Six-bolt red or 12-bolt blue anodized
- Non-vented
- Hardware included

Contact: 805-525-8800  
[jazproducts.com](http://jazproducts.com)



**KELLYMOSS**  
**CUSTOM PORSCHE SERVICES**

- Engine, wire harness, interiors, professional detailing
- Custom builds
- Restorations
- Proven championship-winning professional Porsche racing programs, including vintage

Contact: 608-274-5054  
[kellymoss.com](http://kellymoss.com)



**LEAR CHEMICAL RESEARCH CORP.**  
**ACF-50**

- Keep this anti-corrosion tool in your toolbox
- Protects
- Penetrates
- Lubricates

Contact: 905-564-0018  
[learchem.com](http://learchem.com)



Quality Isn't Expensive... It's Priceless!



SCAN THE QR CODE  
TO VISIT OUR  
WEBSITE!



email us!  
[websales@cheprecision.com](mailto:websales@cheprecision.com)

call us!  
805-499-8885





### LIFELINE USA ZERO 360 SFI 17.1 FIRE-SUPPRESSION SYSTEM

- Available in 5- and 10-lbs. with mechanical and auto/thermal activation
- Uses Zero FK clean agent fire suppression gas, ensuring fast fire knockdown
- No residue or clean-up after discharge
- Safe for electronics
- High-quality delivery and activation system
- Dirt, asphalt, and off-road applications

Contact: 540-251-2724  
[lifeline-fire.com](http://lifeline-fire.com)



### MASTERS ENTERTAINMENT GROUP TV, MEDIA PRODUCTION

- Home of the Motorhead Garage TV series
- Post production
- Live event production
- Live streaming

Contact: 423-968-7736  
[masterstv.com](http://masterstv.com)



### MB QUART 1000-WATT, 14-SPEAKER POLARIS RANGER AUDIO ROOF

- With 7-inch LED source unit and 45-inch light bar (MBQRG4-S14R)
- Dash-mounted GMR7V1 touchscreen CarPlay source unit
- 12 powersports-specific 6.5-inch coaxial speakers
- Two 10-inch powersports-specific subwoofers
- Two 500-watt, 5-channel Class-D amplifiers
- 45-inch half-optic light bar

Source: 847-540-7700  
[mbquart.com](http://mbquart.com)

[na.daycoaftermarket.com](http://na.daycoaftermarket.com)

# Perfect Timing



Learn more here

## Dayco Premium Timing Chain Kits

- Available for early and late model pushrod engines and all late model OHC engines
- Everything you need in one part number
- OE quality chains prevent stretch for the life of the kit
- 2-year/60,000-mile parts & labor warranty

**DAYCO**

MOVE FORWARD. ALWAYS.™



**MOLECULE WATERLESS HANDWASH**

- Quick foaming hand cleaning without need for water
- Conditioning and moisturizing ingredients
- Designed for grease and other tough soils

Contact: 949-429-6706  
[moleculesports.com](http://moleculesports.com)



**MOTEC M1 ECU**

- Port injection, direct injection
- Nitrous, turbos, superchargers
- Drag, street, offroad
- Electric vehicles, drift, hot rod
- Data analysis
- Power management
- Display logger

Contact: 704-799-3000  
[motec.com](http://motec.com)



**PERFORMANCE ELECTRONICS PE-SEALED DASH**

- Monitor critical engine data with the new PE-Sealed Dash
- Water-resistant design
- Compatible with PE3 Series and other CAN-enabled ECUs
- On-screen warnings and alarms
- Screen playback with Min/Max recall
- Robust full-color touchscreen LCD
- Viewable in direct sunlight
- Surface or flush mounting options
- Available in 2025

Contact: 513-777-5233  
[pe-ltd.com](http://pe-ltd.com)

**DON'T GIVE IT A SECOND THOUGHT**



**SERIOUS OIL PUMPS**

The unique Peterson R4 rotor design develops solid oil pressure, even at high temperature conditions and it pulls serious vacuum too. A standard rear drive setup allows for direct mounting of all popular drive accessories. Fire it up, forget about it and know that R4 will help ensure your engine never misses a beat.



**NEW!**  
#14-3112 Ford Coyote Mount

**1.800.926.7867**  
[petersonfluidsys.com](http://petersonfluidsys.com)



**TANKS PRIMERS ACCESSORIES**



By Specialty Products Company

©2024 Niwot Corp. dba Specialty Products Co.®

**SEE US AT PRI  
BOOTH #3413**





**PORTATREE TIMING SYSTEMS  
ELIMINATOR NEXT GEN  
PRACTICE TREE**

- Dual- and single-user mode tree speed (.100 to .900)
- Adjustable roll-out delay box bump up/down perfect tree (e.g. .000 vs. .400/.500)

Contact: 508-278-2189  
[portatree.com](http://portatree.com)



**POWERTUBE TV  
FREE AUTOMOTIVE TV  
STREAMING NETWORK**

- POWERtube TV is a 100% free automotive and motorsports-focused TV streaming network
- Offers a wide range of content, including motorsports, car builds, and off-road adventures
- Accessible on the Web, Roku, Amazon Fire TV, mobile apps, and more
- Features exclusive shows and docuseries, connecting car enthusiasts with high-quality automotive entertainment

Contact: 214-810-6142  
[watchpowertubetv.com](http://watchpowertubetv.com)



**RACETECH SEATS  
4200 SERIES SEATS**

- Enhanced comfort and safety
- Back-mounting, deep shoulder support
- Increased rib support
- Improved head restraint foaming
- FIA 8855-1999 approved
- Three sizes, taller/wider models available
- Enhanced technology
- Lightweight resin-infused shells
- PRI Show booth 5194

Contact: 704-450-4507  
[racetech-usa.com](http://racetech-usa.com)

**SERDI**

**The most reliable engine  
rebuilding equipment**



**See us at  
PRI 2023**

Machinery row  
Booth 5201

**SPT 1600**

SERDI CORPORATION  
customerservice@serdi-usa.com - +1(800) 447-3790 - MOORESVILLE NC 28117





**RACING ELECTRONICS  
TWO-WAY MOTOROLA R2  
SYSTEM**

- The R2 System has everything for the car, crew chief, and driver
- Two Motorola portable two-way radios
- Push-to-talk switch
- Car harness
- Two-way headset
- Headset cable
- Race belt
- Helmet kit
- Roof mount antenna kit with radio adapter
- Driver ear pieces
- Carbon-fiber-style case
- Visit RE at PRI Show booth 4721

Contact: 704-721-5111  
[racingelectronics.com](http://racingelectronics.com)



**RC TRAILERS  
RC TRAILERS**

- Extensive product offering
- Highly customizable trailers

Contact: 574-825-9518  
[rctrailers.com](http://rctrailers.com)



**SCRIBNER PLASTICS  
CYLINDER HEAD SHIPPING  
AND STORAGE CONTAINER**

- Diesel LT6 cylinder head shipping container, PN 5162
- Designed for truck freight shipping of heavy diesel cylinder heads
- Stackable and interlocking
- Ultra tough double-wall base
- Unique bolt closure
- Twin cinch straps to securely capture cylinder head into base
- Internal dimensions: 31.5 x 13.5 x 7.5 inches

Contact: 916-638-1515  
[scribnerplastics.com](http://scribnerplastics.com)

**THE ULTIMATE  
TRACK DAY  
COMPANION**

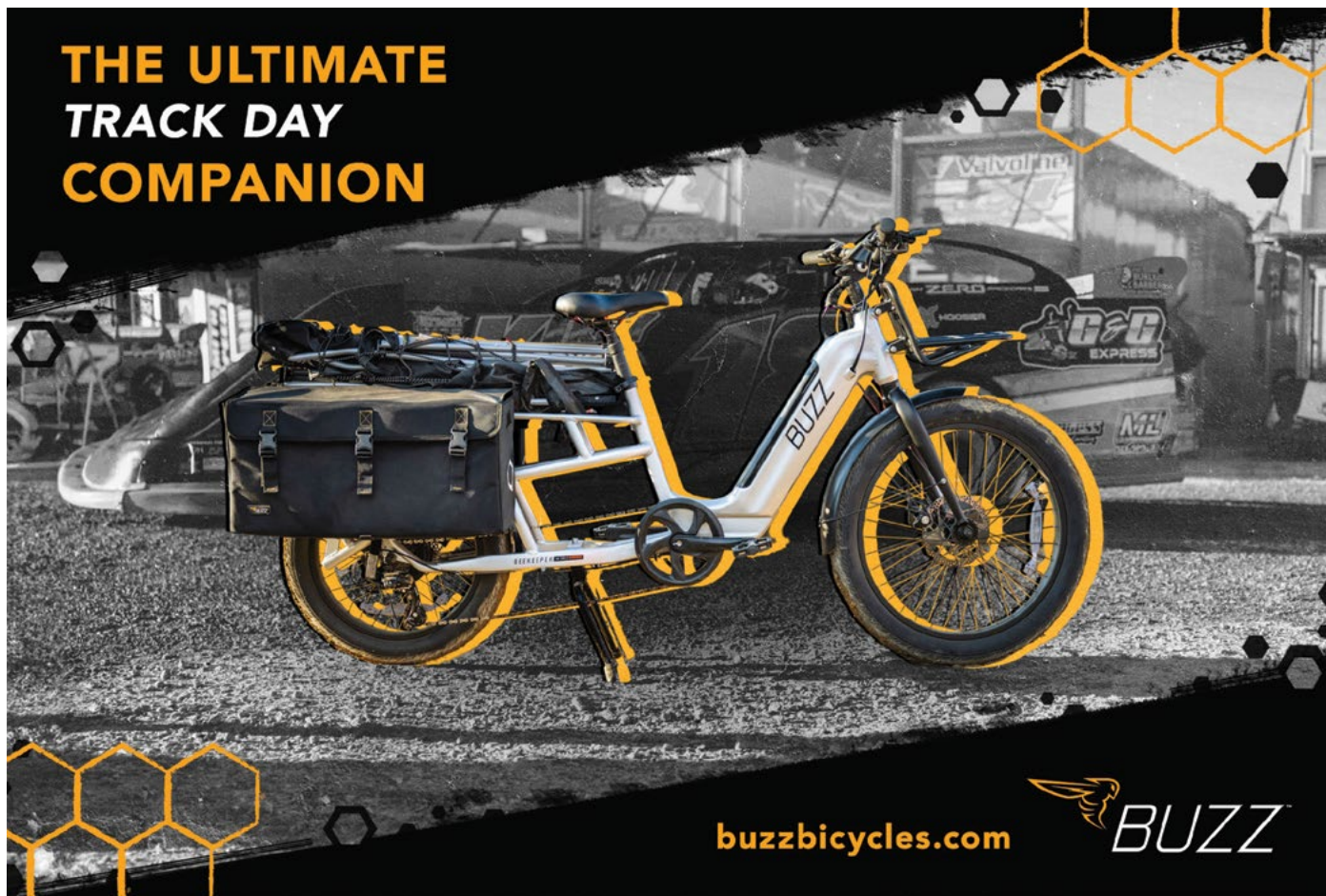

[buzzbicycles.com](http://buzzbicycles.com)





**SHURIKEN BY METRA ELECTRONICS  
LI-BT100-SLIM SHURIKEN  
2000W/100AH SLIM LITHIUM  
IRON BATTERY**

- Where the power source needs to be lightweight and compact, with a quick energy discharge
- Internal components are sectioned into independent cells, making for a safer battery less likely to short out if damaged
- For RVs, marine, motorsports, solar energy storage, and general usage applications
- Overcurrent detection circuit to protect battery from damage
- Constant current or constant voltage charging

Contact: 386-257-1186  
[metraonline.com](http://metraonline.com)



**SOUTHERN ADRENALINE  
CUSTOM-FIT RACE RECEIVERS**

- Custom fit hearing protection made with standard 3.5-mm mono jack and 36-inch cord length
- Plugs directly into your Raceceiver and helps isolate the radio traffic coming from the tower officials at a reduced volume level
- Custom fit for the best protection and comfort
- Standard 3.5 mono jack with variable lengths available

Contact: 817-371-2350  
[southernadrenaline.net](http://southernadrenaline.net)



**STEERING BUDDY  
STEERING BUDDY**

- Allows racers to steer their vehicle remotely when powered off
- Made from 6061 aluminum
- Weighs less than 17 pounds
- Attaches to the steering shaft or column of most dirt, asphalt, or drag cars
- Controlled manually, via the app, or wireless remote
- Powered by a separate tool battery

Contact: 256-624-0645  
[steeringbuddy.com](http://steeringbuddy.com)



**NEW PRODUCTS RELEASED EVERY WEEK!**

**No. 20157  
GEN V LT, CIRCLE TRACK  
ALUMINUM**

**No. 20617  
GEN V LT, DRY SUMP  
STEEL**

**No. 20618  
GEN V LT, DRY SUMP  
ALUMINUM**

**No. 20946  
NC MIATA, ROAD RACE  
ALUMINUM**

**No. 20921  
HONDA/ACURA K-SERIES  
ROAD RACE, ALUMINUM**

**No. 20240  
CFE 5.0 BORE SPACE, MOUNTAIN  
MOTOR PRO STOCK, ALUMINUM**

**No. 22619  
DRY SUMP TANK  
60/40 SPLIT  
W/ PRE-HEATER, 7 QT.**

**PRISHOW BOOTH 4409**

**MOROSO PERFORMANCE PRODUCTS, INC.**  
80 CARTER DRIVE, GUILFORD, CT 06437  
203-453-6571 - [WWW.MOROSO.COM](http://WWW.MOROSO.COM)

@morosoperformance





**STROUD SAFETY  
KEVLAR WINDOW NET**

- Stroud Safety window nets keep you safely inside your car in all situations
- Customized for your vehicle in shape and color
- Exceeds SFI 27.1 specifications with double stitching for long-lasting durability

Contact: 405-632-2022  
[stroudsafety.com](http://stroudsafety.com)

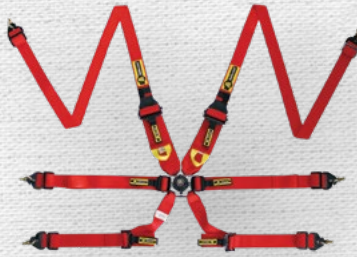

**TAIWAN RACING PRODUCTS CO.  
RCU-1002H ENDURANCE  
RACING HARNESS**

- FIA 8853-2016 approved
- Quick-release turn buckle
- 2- and 3-inch shoulder belts with lightweight aluminum adjusters
- 2-inch pull-down lap belts with integrated tongue adjusters for easy adjustments
- Snap hook and eyebolt end fittings
- FHR only

Contact: +886-4-853-7046  
[beltenick-trp.com](http://beltenick-trp.com)



**TECHNOCRAFT CABINETS  
WHEEL WELL CABINET**

- Ultimate in thin storage using very little space
- Make use of the wall area over your wheel wells
- Three full-length shelves for storing oil, paper towels, cleaning supplies, tools, and more
- 3-inch-tall shelf flanges keep everything in place
- All doors are securely held shut with polished chrome trigger style door latches
- Cabinet weight is centered over your axle so there is no additional tongue weight
- These can also be mounted wherever there is available wall space
- The 8-inch depth matches most wheel wells

Contact: 931-379-5500  
[trailer cabinets.com](http://trailer cabinets.com)

**DISCOVERY**  
TRAILERS.COM

**844-472-7800**

[www.discoverytrailers.com](http://www.discoverytrailers.com)



### TORCO INTERNATIONAL CORP. TORCO SR-1R SYNTHETIC RACING OIL

- 100% synthetic racing oil engineered to exceed the needs of pro racing teams and enthusiasts
- Features a blend of premium Group III, IV, and V base oils, ensuring optimal lubrication and protection under extreme motorsport conditions
- Proprietary MPZ-plus chemistry is designed to increase power, efficiency, and protection
- Available grades: 10W-30, 10W-40, 10W-60, 20W-50, and 25W-60
- High-quality, zero-shear polymers provide resistance to viscosity thinning

Contact: 909-980-1495  
[torcouisa.com](http://torcouisa.com)



### TRAILER ALARMS G2

- Second-generation trailer security system
- With GPS
- Easy to use
- Easy on the wallet

Contact: 877-604-7381  
[trailer-alarms.com](http://trailer-alarms.com)



### ULTRA SHIELD RACE PRODUCTS IN SIGHT TEAROFFS

- 10 sleeve tearoffs sold in bulk quantities of 100 or 250
- A more affordable clear path to victory lane

Contact: 903-894-3550  
[ultrashieldrace.com](http://ultrashieldrace.com)

**AT** AutoTuner

NEW

# A new One joined the family

Multi-brand OBD-II personal flasher

All informations and pre-orders:  
[www.autotuner.com/one](http://www.autotuner.com/one)





**UNITED TRAILERS  
UAT PREMIER PACKAGE**

- X-frame
- Premier cabinet package (L-base, overhead, and closet cabinets)
- Rubber coin floor
- White aluminum ceiling/walls
- Marine-grade carpet wall base
- Radio package
- Dexter torsion axles (available in TA52 and TA70 models)
- Optional premium jump door
- Spare-tire well
- 110V electrical package
- Winch plate
- Electric tongue jack

Contact: 800-637-2592  
[united-trailers.com](http://united-trailers.com)



**VBOX MOTORSPORT  
VBOX VIDEO HD2**

- VBOX's most sophisticated race car video data logger
- VBOX Video HD2 features 1080p video
- Real-time synchronized video and data with graphical overlay
- Dual-camera input with live preview
- 1080p 30 fps HD video
- Real-time HD graphic overlay
- Up to 80 CAN channels
- HDMI for live video streaming

Contact: 248-994-9050  
[vboxmotorsport.com](http://vboxmotorsport.com)



**VORTEX WEATHER INSURANCE  
HOURLY RAIN INSURANCE**

- Parametric hourly rain insurance works to mitigate revenue loss caused by rain
- If the recorded rainfall at your location during your coverage window meets or exceeds your pre-selected threshold, you get paid
- Claim payments are typically mailed in about two weeks
- No proof of loss required
- Cancellation is not required

Contact: 866-997-2469  
[vortexinsurance.com](http://vortexinsurance.com)

SPECIAL OFFER



423.979.0309    MADE IN THE USA    WWW.JD2.COM

Booth  
5649



**Model 54**  
JD SQUARED INC

US Manufacturer of  
Metalworking Tools

VISIT US

Discover our exclusive show specials!



**POWER • PERFORMANCE • PERFECTION**

**SDPC**  
SCOGGIN DICKEY PARTS CENTER



CHEVROLET

**Performance**

Vehicles / Parts / Racing



GENUINE  
PARTS

**ACDelco**

SDPARTS.COM • 1-800-456-0211

VISIT US AT BOOTH #4321

**LS**  
**SBC**  
**BBC**  
**409**  
**SBF**  
**HEMI**  
**WEDGE**

**LESS WEIGHT = PERFORMANCE**

All BMP Blocks are made from 357T6 Aluminum & have billet steel caps, ARP Studs, replaceable Ductile Iron Sleeves & accept OEM Accessories. Our goal to supply nothing but the best at affordable prices.

Check Out Our Huge Selection Of High Performance Parts at [BILLMITCHELLPRODUCTS.COM](http://BILLMITCHELLPRODUCTS.COM)

**386.957.3009**

**BMP** HARD CORE RACING  
BILL MITCHELL PRODUCTS



**VP RACING FUELS**

**VP RACING FROSTY CLEAN**

- Eco-friendly cooling system cleaner and flush
- Removes gels and sediments
- Neutralizes acids
- Lubricates the water pump
- pH-neutral to protect aluminum components
- Ensures optimal cooling system performance

Contact: 702-241-3331

[vpracingfuels.com](http://vpracingfuels.com)



**XRP**

**FLUID TRANSFER HOSES AND HOSE ENDS**

- High-performance
- Rubber hoses
- PTFE hoses
- Hose ends
- Adapter fittings
- Filtration products

Contact: 562-861-4765

[xrp.com](http://xrp.com)



**ZAMP**  
**GO HEAD-TO-TOE WITH ZAMP**

- Quality safety gear for all types of racing
- Snell-, FIA-, SFI-, DOT-, and ECE-rated helmets with wide range of graphics
- SFI and FIA suits, including custom suits
- SFI head-and-neck restraints and collars
- SFI gloves and shoes
- SFI and FIA seat harnesses
- Wide range of accessories

Contact: 208-506-3030  
[zamp-racing.com](http://zamp-racing.com)



**ZYCOAT**  
**ZYCLEAR HIGH-TEMPERATURE, HEAT-DISSIPATING CLEAR COATING**

- ZyClear breakthrough high-temperature, heat-dissipating clear coat reduces under-hood temperatures by over 30%
- Is wiped on or spray applied with an air-brush and fully air cures in 60 minutes
- ZyClear is applied to stainless steel, titanium, and prevents metal discoloration
- Apply ZyClear on headers, turbos, downpipes, exhaust, manifolds, and other engine components
- ZyClear comes in easy application kits, including surface cleaner, ZyCoat lint-free wipes, and gloves

Contact: 913-599-2600  
[zycoat.com](http://zycoat.com)

**CRAFTED IN THE USA**



**Perform at a higher level...**

**and eliminate your competition.**



With over 20 years of experience in fabricating custom and high-performance exhaust systems for race cars, vehicle restylings, and restorations—you might say we're obsessed. All Grand Bending products are available in aluminized carbon steel and stainless steel thin-wall tubing and utilize short-radius tube bends measuring 1½–5 inches.

Got a new project coming up? Call **770-426-0734** or email us at [sales@grandbending.com](mailto:sales@grandbending.com) today.

*Learn more!*

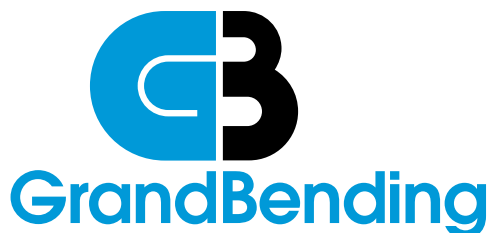

[GrandBending.com](http://GrandBending.com)



SECTION

4

# MACHINERY, TOOLS & EQUIPMENT

Whether honing, welding, cutting, or grinding, new equipment that was designed to improve productivity is featured in this section. These new tools and machinery can be integral to improving the bottom line in 2025 and beyond.





# ITALIA @ **PRI**SHOW

Discover the Excellence of the  
Italian Automotive Aftermarket Industry

Visit us at booth **2850-2832**

## MADE IN ITALY

DISCOVER OUR EXHIBITORS



BOOTH		BOOTH	
2850	CEMB	2850	ITA / ANFIA / AICA
2850	CUBE CONTROLS	2832	M.E.RIN
2832	EVO CORSE	2832	PISTAL RACING
2832	FRI.TECH.	2832	SCARPA E COLOMBO
2850	GMC - RACING		

# COMEC

comecus.com | 800-887-6076



## ACF200CNC

- CNC boring mill
- Simple conversational operation
- Dual-panel touchscreen control
- Ballscrew drives, linear slideways and brushless servomotors
- Boring, milling and fixturing included
- 2.4- to 6.7-inch boring diameter standard
- CBN/PCD milling head



## RP1400CNC

- Simple conversational operation
- Dual-panel touchscreen control
- 16-inch CBN/PCD milling head
- Cutter and column height stored in memory
- Laser surface scanning
- Automatic and manual control modes
- Capacity for large diesel heads and blocks



## LEV300 CYLINDER HONING MACHINE

- Programmable vertical stroke cylinder honing machine
- Simple touchscreen operator control
- Adjustable crosshatch angle
- Friction feed hone head/uses standard Sunnen AN-type stones
- Software adjustable upper and lower overstroke
- User definable Dwell parameters
- Universal block mounting fixture, holds up to 35-inch long V and inline blocks



## RV516ASM

- High precision valve refacer
- Centerless chuck design
- Infinitely variable workhead rpm
- 4-mm to 5/8-inch valve stem diameter capacity
- 0-60 degree angle, up to 4-plus inches head diameter capacity
- Wheel dresser and micrometer butt grinder included
- Workstand included

# CTECH MANUFACTURING

ctechmanufacturing.com | 715-355-8842



## ECONO9 GARAGE CABINET PACKAGE

- Durable, corrosion-resistant aluminum alloy construction
- MotionLatch cabinet doors and gasket-sealed countertop
- Easily adjustable feet and shelving
- Ships fully assembled in one to two business days



## CONFIGURABLE WORKTOP CART

- Unobstructed working surface with dual-sided storage access
- Dedicated push/pull/tow chassis for easy trailer transport and paddock maneuverability
- Customize size, color, options, drawer stacks, and more online



## CONFIGURABLE PRO TRAILER BASE CABINET

- Tough powder coat finish
- Lightweight aluminum alloy construction
- Gasket-sealed countertop
- Customize this cabinet extensively using an interactive online builder



## HALF ASS SERVICE CART WITH MOTIONLATCH DRAWER

- Airless "HalfAss Casters" combine the maneuverability of a caster with the smooth roll of a pneumatic tire
- MotionLatch top drawer for convenient tool storage
- Removable top tray for easy cleaning
- All components are powder coated prior to assembly for ultimate longevity

## GIANT FINISHING

giantfinishing.com | 708-343-6900



### GIANT MODEL W-5 VIBRATORY TUB

- 5 cu. ft. working capacity with a 19-inch x 35 1/2-inch process chamber
- Steel-hinged sound enclosure
- 110 V 1 PH with variable frequency drive plug and play
- Locking casters for portability
- 10-gallon steel fabricated settling tank with pump for fluid management
- Many other options available



### GIANT MODEL GB-3 VIBRATORY BOWL

- 3 cu. ft. of working capacity with a 9-inch process chamber
- Internal separation for parts unloading
- 110 V 1 PH with variable frequency drive plug and play



### GIANT MODEL GCB-40 HIGH ENERGY CENTRIFUGAL BARREL TUMBLER

- Four cradles with multiple barrel options
- Variable speed drive
- 12.5-inch x 6.75-inch diameter barrels (four)
- 1.4 cu. ft. working capacity



### GIANT GSB SLURRY BLASTER

- 48-inch x 36-inch work area
- Ergonomic blast gun
- Window wiper with water control knob
- Foot pedal operation

# HOOSIER PATTERN

hoosierpattern.com | 260-724-9430



## 3D PRINTING

- Five in-house state-of-the-art 3D sand printers print geometrically complex molds and cores, bypassing tooling fabrication and drastically reducing lead times
- To meet client's expectations, every printed project contains 15 test bars and permeability pucks that test the core strength, XYZ directional tolerance, dimensional strength, and permeability
- Initial tests are performed when prints are complete and then again in 24 hours



## SAND CLEANING

- Hoosier Pattern's 3D sand cleaning department is the last stop the 3D sand prints pass through before they are packaged and shipped to the customer
- Highly trained and detailed employees ensure that each mold meets quality control standards
- Uses a two-check system in which an employee and auditor verify that every mold and core passes inspection

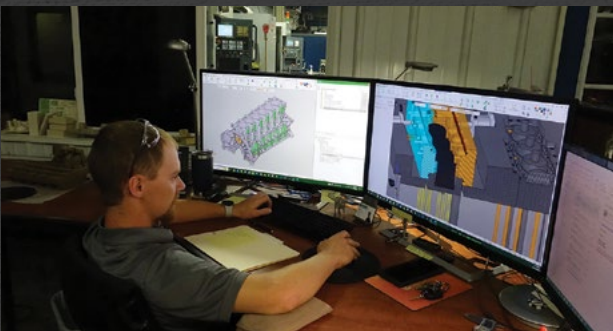

## CAD/CAM

- CAD/CAM department works with customers to provide foundry tooling for their molding or core machines
- Hoosier Pattern stays up to date with their standards when developing and maintaining the necessary tool build files and backing them up to the company server for future use daily and offsite weekly
- Throughout the process, Hoosier Pattern communicates and collaborates via web conferencing ensuring customers receive exactly what they need



## MACHINING

- For over 25 years, Hoosier Pattern has offered foundry tooling proudly serving regional and national clients from small jobs to large-scale projects
- Employees come from various occupations and skill sets within the machining and foundry industry
- Technical background, latest technology, extensive training, and an active apprenticeship program allow Hoosier Pattern to constantly deliver high standards to our customers

## IRONTITE PRODUCTS KWIK-WAY VAN NORMAN

irontite.com | 319-377-9421

**irontite**  
THE PROFESSIONAL'S CHOICE

A family of brands trusted for over 100 years.

**KWIK-WAY**  
BY IRONTITE

**VAN NORMAN**  
BY IRONTITE



### KWIK-WAY SVSIID VALVE GRINDER

- Manufactured in the USA since the 1920s, the Kwik-Way valve grinder SVSIID is an accurate system for refacing valves
- The exclusive Kwik-Way six ball Centerline chuck ensures perfect concentricity for reliable and repeatable precision
- Backed by a solid three-year limited warranty



### VAN NORMAN FG5000 FLYWHEEL GRINDER

- The original American-made flywheel grinder
- Exclusive solid cast table support means no deflection
- Direct-drive table
- Productive and rugged flywheel grinder. Fast grinding for the race industry



### IRONTITE DIESEL INJECTOR SLEEVE TOOLING

- The Irontite Diesel injector sleeve removal and installation kits are made in the USA and designed to install the injector sleeve to OEM specifications
- Made with precision materials, the Irontite Diesel kits are made for Cummins, Paccar, Navistar, GM/Detroit Diesel, and Caterpillar
- Machinists around the world choose Irontite. The professional's choice



### IRONTITE CRACK DETECTION AND REPAIR KITS

- The Irontite Crack Repair System is a cold repair process for repairing castings
- The cold crack repair process does not alter the casting like welding does
- The detection and repair kits supply all the tooling needed to return the casting to "Irontite" condition

# JACKPAK

jackpak.com | 800-253-2363

**JACKPAK**  
By BendPak



## JACKPAK ULTRA2500A

- 4-in-1 car battery jump starter
- This versatile battery pack acts as a jump starter, air compressor, LED flashlight, and even a charger for mobile devices
- Compact design allows for easy storage in small spaces

# LITESTIX BY BENDPAK

bendpak.com/litestix/ | 800-253-2363

**BendPak.**



## LITESTIX

- Versatile LED portable work light designed for heavy use
- A total of 36 super-bright LED bulbs provide brilliant lighting coverage anywhere you need, perfect for nighttime and other low-light projects
- Includes a large-capacity 2,600 mAh Li-ion battery that has been thoroughly tested to last up to six hours of continuous use
- An impact resistant polycarbonate light housing, all-steel telescoping light tube holder latches from 49.5- to 79.75-inch lengths, and two swivel-head mounts with built-in magnets provide all the flexibility and versatility to illuminate your next project



# MAXJAX BY BENDPAK

maxjax.com | 844-629-5291

## MAXJAX®



## MAXJAX

- Patented portable two-post lift designed to fit in your garage or automotive professional shop
- Perfect for low buildings with low ceilings
- MaxJax is equipped with five anchor bolts in each column that are capable of securing up to 16,500 lbs. each. That's roughly 82,500 lbs. of pressure being applied down for each column

# MRCOOL

mrcool.com | 270-366-0457



## DIY SINGLE ZONE SERIES

- Easy DIY installation
- Smartphone app
- Easy quick connect line set
- DC inverter



## ADVANTAGE SERIES

- DC inverter
- Quiet operation
- Gold fin condenser
- HVAC technician required



## MOUNTING BRACKETS

- Protects condenser from debris and pets
- Solid steel painted construction
- MB176 supports up to 176 lbs.
- MB440 supports up to 440 lbs.



## MRCOOL CARE KIT

- Foaming coil cleaner
- Pull rod spray gun and water bottle
- Water collection bag and drain hose
- Air freshening filter

# PALMGREN

palmgren.com | 800-827-3398



## 9681123 – 6" X 48" BELT & 10" DISC

- Palmgren's 6" x 48" Belt and 10" Disc Sander is designed with any fabrication application in mind
- Heavy-duty 1.5 horsepower direct-drive power train for more torque



## WOOD/METAL COMBINATION VERTICAL BAND SAWS

- Palmgren's combination vertical band saws come in 15", 18", and 20" throat depths
- What makes these saws unique is their two-pulley system combined with a direct drive transmission assembly
- This system provides high speeds for cutting wood and plastics, but also a mix of low speeds for cutting ferrous and non-ferrous materials



## HOLE TAPPING SOLUTIONS

- Providing a full assortment of pneumatic and electronic tapping arms, Palmgren has tapping solutions for holes as small as M3 and as large as 2"
- All Palmgren tap holders have a ratcheting function that engages when tapping blind holes to reduce the chance of breaking a tap when reaching the bottom of a hole



## H-FRAME PRESSES

- With size ranges from 5-ton to 100-ton, Palmgren offers 10 different H-frame presses with either manual operation or electronic operation
- Every frame is constructed of heavy-duty steel with leak-free steel cylinders
- A key piece in any fabrication shop, H-presses are the ultimate do-it-all tool used for assembly, straightening, bending, forming, punching, and shearing applications

## QUICKJACK BY BENDPAK

quickjack.com | 888-262-3880



### QUICKJACK 5000TL

- 5000TL portable car lift adds an extra 3 inches bringing the lifting height to 24 inches
- This enhancement increases access to the undercarriage of the vehicle and provides an overall increase to your comfort and capability
- QuickJack handles the lifting and safe keeping of a vehicle with the simple push of a button
- No crossbeams are on the ground to get in your way
- Each of the two frames feature automatic locking bars that are essentially "jack stands" built right into the sides
- Perfect for performing any job with jacks and stands
- 5,000 lbs. capacity
- 70-inch frame length

# SUNNEN PRODUCTS COMPANY

sunnen.com | 800-325-3670



## SV-35 CYLINDER HONE

- The next generation heavy-duty engine block honing solution with over 250 machines sold since 2013
- Constant crosshatch from top to bottom of the bore for optimum ring sealing
- New Sunnen2 system controls for simple setup and operation
- Manual and Automatic Step and Repeat models available



## SV-15 CYLINDER HONE

- The proven engine block honing solution since 1964—perfect for low production applications—over 8000 sold
- Large color touchscreen with easy-to-use controls
- Up to 100 setups can be saved with USB backup
- Bore profile display allows honing to end specs without stopping to gage bores



## SH-4000 HORIZONTAL HONE

- Perfect for performance connecting rod production
- Easy to set up and operate with minimal operator training
- Controls perpendicularity, roundness, straightness, and surface finish
- Can also be used for piston pin bores, turbochargers, small engine cylinders, and other engine components



## CH-100 LINE HONE

- CH-100 is the industry standard for line honing of main bearing bores
- New heavy-duty four-speed spindle drive
- Brings main bores back to perfect alignment with minimal stock removal
- Accommodates a wide variety of engine blocks

## YOURDYNO

yourdyno.com | Kevin: 603-491-5961/Jostein: +47 4840 1279

YourDyno.com  
Professional dyno instrumentation

## YOURDYNO ULTIMATE INSTRUMENT UNIT

- Latest YourDyno Ultimate Data Acquisition, 35 channels; 16 aux, eight thermocouples, six digital, one engine rpm pickup, four load cells. Plus three weather channels, and unlimited math channels
- Built-in CAN bus support with data in and out (data can be read from CAN sensors or ECUs, and data channels can be sent to CAN devices like ECUs, dashboards, loggers etc.)



## YOURDYNO 13" DUAL ROTOR WATER BRAKE ASSEMBLY

- 13-inch toroidal Siamese billet absorber 2,500 hp
- Trunnion mount
- 10,000-plus rpm high-speed bearings
- 1.875, 27-spline nickel-plated shaft



## AUTOMATED LOAD CONTROL VALVE KIT FOR WATER BRAKES

- The kit contains the valve itself (1 inch, 1.5 inches, or 2 inches), the servo motor, servo controller and power supply
- Default is pipe connection (1 inch, 1.5 inches, or 2 inches NPT thread), alternatively or 1 inch, 1.5 inches, or 2-inch hose connection
- Very fast and accurate valve, stainless steel, heavy-duty construction
- Polished stainless steel valve internals for good flow. Easy to install, disassemble and service if necessary



## YOURDYNO UNAVISION

- The YourDyno UnaVision software is comprehensive, modern, and easy to use. It can control any dyno type and read all common dyno sensors
- All runs are stored in a database, with search capabilities, filtering and grouping. Raw data and settings are stored for each run
- Load control: An alternative to power sweep, which lets the engine run through the rpm range in a more natural way (accelerates more where it is strong and less where it is weak). This mode is particularly good for water brake and engines/vehicles with sudden torque band



**ADVANTAGE LIFTS  
DX-9000-XLT**

- Extra tall and extra long for trucks, SUVs and more
- Automatic engaging wheel stops
- Outside slider design
- Industrial grade cables and pulleys
- Primary and secondary locking systems
- ETL recognized power unit
- Five-year limited warranty

Contact: 763-300-5730  
[advantagelifts.com](http://advantagelifts.com)

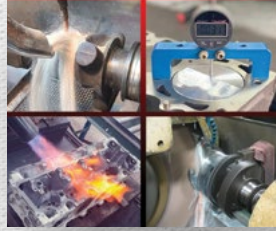

**AERA ENGINE BUILDERS ASSOCIATION  
AUTOMOTIVE MACHINING &  
ENGINE REPAIR**

- New 2024 edition now available
- Updated training material in 18 chapters
- More than 1,000 new color photos
- New test questions to help push future machinists to the next level
- An ideal book to help students prepare for certification exams in engine repair and automotive machining
- Order online: [aera.org/store](http://aera.org/store)

Contact: 815-526-7348  
[aera.org](http://aera.org)



**CLAMPTITE TOOLS  
PREMIUM MINI CLAMP TITE  
TOOL KIT**

- Custom clamp making tool
- Up to 10 times stronger and 90% lighter than a regular clamp
- True 360-degree seal with no flat spots
- Provides a way to tighten wires wrapped around an object and then lock it in place

Contact: 800-962-2901  
[clamptitertools.com](http://clamptitertools.com)

**KEEP UP WITH PRI**

f x y ln @ d

[PRISHOW.COM/SOCIAL](http://PRISHOW.COM/SOCIAL)

**PRI**  
PERFORMANCE RACING INDUSTRY



### CRYSTAL CLEAN AUTOMOTIVE PARTS WASHERS

- Manual, automatic, and ultrasonic models available
- Regularly scheduled service and refill intervals from professional reps
- Crystal Clean provides the machine, cleaning chemistry, and great service you deserve

Contact: 630-333-5901  
[crystal-clean.com](http://crystal-clean.com)



### FANUC AMERICA CORPORATION ROBODRILL α-D28LIB5ADV PLUS Y500

- Designed for peak performance covering a wide range of tasks and excelling at machining large workpieces
- Extended Y-axis stroke (500 mm) and increased table size
- Shorter drilling and tapping operations via a rapid Z-axis acceleration (2.2 G) and traverse rate (60 m/min)
- Expanded 28 tool capacity, lightning-fast changes

Contact: 248-830-3020  
[fanucamerica.com](http://fanucamerica.com)



### FENTECH CO. DCB-2000 DYNAMIC CRANKSHAFT BALANCING MACHINE

- Offers engine builders unmatched precision and durability
- Includes Fentech's advanced, user-friendly software designed for easy operation
- Advanced software identifies imbalances from 0.01 to 1,000 grams, on work pieces up to 500 pounds, fine tuning your rotating assembly for high performance
- Made in the USA

Contact: 636-349-0588  
[fentechcoinc.com](http://fentechcoinc.com)

## WHY DUPLICATE — WHEN YOU CAN — INNOVATE



The **ATL Vortex Pro** is an innovative top plate design that utilizes a venturi system feeding a unique pressurized accumulator in place of a collector fed by lift pumps. This accumulator means no pressure dropouts at low fuel loads and improved temperature characteristics. Lower fuel temperatures practically eliminate the risk of cavitation, ensuring consistent fuel pick-up.



Multiple  
Fill Neck  
Options

USA

+1 201 825 1400  
[atl@atlinc.com](mailto:atl@atlinc.com)  
[atlinc.com](http://atlinc.com)

UK

+44 (0)1908 351700  
[sales@atlltd.com](mailto:sales@atlltd.com)  
[atlltd.com](http://atlltd.com)

**PRI  
SHOW**  
BOOTH #  
**1119**

**Hypermax**  
ENGINEERING

255 EAST ROUTE 72 GILBERTS IL 60136  
**GOHYPERMAX.COM**  
847-428-5655 DIESEL POWER

**BONE TWISTER**

**PERFORMANCE PRODUCTS FOR  
DIESEL TRACTOR & PICK-UP  
TRUCK PULLING MACHINES**

- \*TURBOCHARGERS
- \*FUEL SYSTEMS
- \*COMPLETE ENGINES
- \*ENGINE COMPONENTS
- \*CLUTCHES & FLYWHEELS
- \*TRANSMISSION GEARS

**TURBOCHARGERS  
& COMPONENTS**

**"BULLET PROOF"  
IHC CRANKCASE  
CASTING**  
4 bolt mains/crossbolts  
with 28 headbolts

**"HIGH FLOW"  
CYLINDER HEAD**  
shown with  
IHC crankcase

**INJECTION SYSTEMS**  
6 & 8 cylinder engines

**7.3L IN-LINE FUEL INJECTION  
PUMP ENGINE**  
Common Rail system also available

**VALVE TRAIN  
COMPONENTS**

**ENGINE  
COMPONENTS**

**MANIFOLDS**

**CYLINDER SEALING**

**HYPERMAX  
DIESEL FUEL INJECTION**

- \*IN-LINE MECHANICAL INJECTION PUMPS
- \*COMMON RAIL INJECTION SYSTEMS FOR  
6.7L FORD & 7.3L NAVISTAR ENGINES

**FORD DIESEL PERFORMANCE**

- \*PICK-UPS, VANS, EXCURSIONS
- \*ENGINE COMPONENTS
- \*EXHAUST SYSTEMS
- \*INJECTORS
- \*INTERCOOLERS
- \*TURBOCHARGERS
- \*ELECTRONICS

136 PERFORMANCE RACING INDUSTRY | DECEMBER 2024





**GREPOW  
LOKITHOR APARTX  
DETACHABLE JUMP STARTER**

- Innovative, sustainable design
- Detachable battery for easy replacement
- Reduces maintenance costs
- 4,000A LiPO option with battery warming technology ensures reliable performance in extreme -40°F conditions
- Choose from multiple battery options, saving up to 70% on replacements
- Enjoy seamless power on demand

Contact: 925-364-7166  
[grepow.com](http://grepow.com)



**GUNI WHEEL  
GUNI WHEEL X**

- Vehicle repositioning wheel with interchangeable hub inserts
- Converts to free-spinning wheel by removing four outer bolts
- Four color-coded hub patterns with slotted lug holes for adjustability
- 24-inch overall height for increased clearance on automotive repairs

Contact: 404-457-4018  
[guniproducts.com](http://guniproducts.com)



**GZERO ADDITIVE  
43 SERIES 3D PRINTER**

- Industrial 3D printers made in America
- Print parts up to 16.3 x 13.9 x 41.0 inches
- Arrives assembled, tuned, and ready for production
- Print a variety of engineering-grade materials
- 110-volt, 10-amp
- Fits through standard doorway

Contact: 859-242-5074  
[gzeroadditive.com](http://gzeroadditive.com)

**AN IMPORTANT NAME**  
*in the world of Racing...*

**WOOLF AIRCRAFT**  
*Detroit, Michigan*

**SCHUMANN'S PERFORMANCE  
WET SUMP OIL PUMPS**

DRAG } ALL CLASSES  
 CIRCLE }  
 TRUCK RACING }

**NEWEST PATENTED DESIGNS!**

- "140 PRO MAX", Low Load Bypass
- "PADDLE WHEEL", Gear to Gear SBC, BBC, OLDS, Pontiac

**ENERGY RECOVERY**

- 30 to 40% Less Energy to Operate
- Turbo Charged Intake Cycle
- No Atmospheric Pressure
  - Vacuum Pan Friendly
- "ANNULAR FLOW" LS Engine Technology

**"WET SUMP OIL PUMPS"  
WITH DRY SUMP ATTITUDE**

**SCHUMANN'S**  
 SALES & SERVICE  
 BLUE GRASS, IA

Call Verne at  
**1-563-381-2416**  
 PO Box 128, Blue Grass, IA 52726  
[www.schumannssalesandservice.com](http://www.schumannssalesandservice.com)  
[sss1554@aol.com](mailto:sss1554@aol.com)



**HECK INDUSTRIES  
BOSS 16 SHEET-METAL BRAKE**

- 16-gauge capacity
- 4-foot length
- 16 removeable fingers

Contact: 810-632-5400  
[woodwardfab.com](http://woodwardfab.com)



**HEIDENHAIN CORPORATION  
MILLPWRG2 CNC MILLING  
CONTROL**

- Intuitive, entry-level CNC control for knee and bed mill operations requiring manual and automated machining
- Operates as a full-function digital readout system, a programmable CNC control, or both
- Brought to you by Acu-Rite Solutions, a part of the Heidenhain Family of Brands

Contact: 847-490-1191  
[heidenhain.us](http://heidenhain.us)



**HUNTER ENGINEERING CO.  
MAVERICK TIRE CHANGER**

- Fully variable controls give the technician complete authority in the tire-changing process
- Uniquely designed SmartSet toolhead is easy to use
- Hydraulic speed and accuracy are the best in the business
- Smart safety features protect the wheel, tire, and technician
- InflationStation fills tires quickly to correct pressure

Contact: 314-731-0000  
[hunter.com](http://hunter.com)

**XS  
POWER  
BATTERIES**

**CONSTANTLY MORE THAN  
JUST BATTERIES**

BOOTH #3621

[XSPOWERBATTERIES.COM](http://XSPOWERBATTERIES.COM)

Visit Us at PRI Booth #4406

**PRECISION SHIMS  
WIN THE RACE**

**BOKER'S, INC.**

Get a Fast Quote 

SCAN OR EMAIL SPECS TO  
[SALES@BOKERS.COM](mailto:SALES@BOKERS.COM)

PRECISION SHIMS, WASHERS & STAMPINGS—SINCE 1919  
(800)-WASHERS [shimstacks.com](http://shimstacks.com)



**IPG PHOTONICS  
LIGHTWELD HANDHELD  
LASER WELDING & CLEANING  
SYSTEMS**

- LightWELD laser welding is fast, easy to learn, and produces high-quality, consistent results across a wide range of materials and thicknesses
- Pre-weld and post-weld laser cleaning functionality optimizes weld quality while increasing productivity
- Made in the US to ensure full control over product quality

Contact: 508-373-1100  
[ipgphotonics.com](http://ipgphotonics.com)



**LARSON SYSTEMS  
VALVE SPRING TESTER**

- LSI's valve spring tester will be an indispensable part of your engine maintenance
- Compression testing of force and length
- Standard 5-inch range/stroke
- Standard 0.001-inch length resolution
- Up to 4-inch Ø platform (2-inch standard)
- 200 lbf, 750 lbf and 1,500 lbf load capacities
- Built-in length deflection compensation

Contact: 763-780-2131  
[larsonsystems.com](http://larsonsystems.com)



**MAGIDO USA  
MAGIDO X-53 PARTS WASHERS**

- Robust parts washers for engine builders
- Front-loading design, wash nozzles, and a rotating turntable for thorough cleaning
- Standard features include stainless steel construction and a PLC/HMI screen for efficient operation

Contact: 844-462-4436  
[magidousa.com](http://magidousa.com)

**UNBEATABLE PERFORMANCE**



- the all-new setrab **super** series remote oil coolers.
- smaller size, larger performance
- absolutely none better.

**Setrab**

see more of what's cool at [www.susa.cool](http://www.susa.cool)

**sūsa**  
SetrabUSA.com



Visit Us at the 2024 PRI  
Trade Show to Learn  
About SCS Gearbox &  
Probell Racing Products

**Booth # 4206**



[SCSGEARBOX.COM](http://SCSGEARBOX.COM) | [PROBELLRACING.COM](http://PROBELLRACING.COM)

419-483-7278



**MADE IN**  
UNITED STATES OF AMERICA



**MITYVAC**  
**MITYVAC MV7454 AND MV7455**

- 10-mm internal tube to move thicker fluids effortlessly
- 10-liter reservoir for longer dispensing
- Replaceable tubing for repair or customization
- Available as a hand pump or pneumatic pressurization
- Fluid level indications on the reservoir to monitor fluid levels
- Simple, rugged design
- Assembly can be used with existing MV6400 or MV7100 lid

Contact: 314-679-4200  
[mityvac.com](http://mityvac.com)

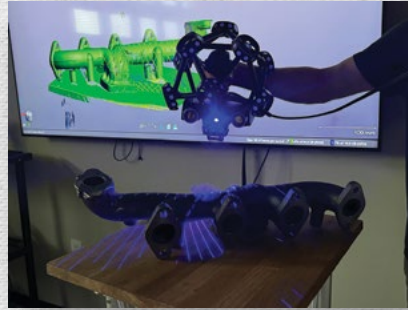

**ONLINE RESOURCES**  
**CREAFORM 3D SCANNER**

- Metrology grade
- Reverse engineering
- Digital twin models
- 3D reconstruction
- Dimensional inspection
- Up to .0005-inch accuracy, .004-inch resolution
- Blue laser technology offers precision, efficiency

Contact: 765-482-9700, ext. 75  
[onlineresourcesinc.com](http://onlineresourcesinc.com)



**PRO ULTRASONICS**  
**PRO 4230LT**

- "Engine Builders Dream," this heavy-duty, ultrasonic cleaning machine includes a 1,000 lb. agitating, lift table and a cooler flush system to maintain all of your coolers
- The powerful ultrasonics clean all of your tough projects—"hands-free"

Contact: 828-584-1005  
[proultrasonics.com](http://proultrasonics.com)

**PROFESSIONAL  
STRENGTH  
CORROSION  
INHIBITORS  
AND  
LUBRICANTS**



**SUSPENSION - ENGINE - ELECTRONICS  
KILLS CORROSION ON CONTACT**

Stop by for a  
**FREE SAMPLE**

LEAR CHEMICAL RESEARCH CORPORATION  
[www.acf-50.com](http://www.acf-50.com) 1.800.256.2548

**PRI** BOOTH# 1611



*Put the best in your LS!*



The NH Series H Beam 300M Rod is designed to be the strongest and most durable rod on the market. This series has increased cheek surface and increased radius to stabilize the Big End in high horsepower and high torque applications!!

**BOOTH # 1904**

PHONE: 1.800.TOP.RODS EMAIL: [ROGER@DYERSRODS.COM](mailto:ROGER@DYERSRODS.COM)

**[WWW.DYERSRODS.COM](http://WWW.DYERSRODS.COM)**



**QUANTUM MACHINERY GROUP  
SIEGMUND SYSTEM  
16 IMPERIAL SERIES  
WORKBENCH**

- Must have for small business, DIY enthusiast, or large-scale fabricators
- Plasma nitrate, perforated tool steel surface for durability and corrosion resistance
- 16-mm hole grid for versatile clamping
- Adjustable legs and reversible top for added functionality
- Supports up to 550 pounds
- Lightweight, extruded aluminum frame for easy mobility
- Available accessory bundles for a complete setup

Contact: 704-703-9400  
[quantummachinery.com](http://quantummachinery.com)



**RMC ENGINE REBUILDING EQUIPMENT  
RMC ETS100 ENGINE TESTING  
SYSTEM**

- High performance
- Production re-manufacturing
- Diesel
- New engine development
- Test your engine assemblies for costly return or warranty issues before you send them out the door

Contact: 989-754-3611  
[rmcengine.com](http://rmcengine.com)



**RW THOMPSON  
KNKUT FIVE-PIECE LEFT-  
HAND STEP POINT MECHANICS  
LENGTH DRILL BIT SET**

- Made In USA; may eliminate the need for a screw extractor
- Left-hand drill bits must be used with the drill motor in reverse mode
- Split point step design starts on contact, self-centers and eliminates the need for a center punch
- Body and clearance are Gold Surface Treated for maximum lubricity
- Mechanics length provides a shorter sturdier construction

Contact: 770-979-1997  
[knkut.com](http://knkut.com)

ONE STOP FOR ALL YOUR PERFORMANCE NEEDS

**PRP**  
PHILADELPHIA RACING PRODUCTS

Over **25 YEARS**  
of manufacturing excellence

**Come check out our new products  
PRI 2024 - Booth #2137**

American made products — Supplying the racing industry for over two decades!

TRACK TESTED  
RACER APPROVED!

[prpracingproducts.com](http://prpracingproducts.com)

**GANDRUD** **PERFORMANCE PARTS**

**WE HAVE THE MOTOR YOU NEED FOR A WINNING SEASON.**

BUY NOW!

CT525 CT350

**FREE SHIPPING! FREE SHIPPING! FREE SHIPPING!**

1-888-284-7491 | [GMPERFORMANCEMOTOR.COM](http://GMPERFORMANCEMOTOR.COM)



**PANELfast**

Exclusively By: **Bentley's**

# 1/4 TURN FASTENERS

MADE IN THE USA

AVAILABLE IN:

**STEEL OR ALUMINUM**

7075 ALUMINUM OR GRADE 8 STEEL

**MULTIPLE FINISHES**

RAW, ANODIZED BLACK OR GOLD

**100+ VARIATIONS**

HEADS/GRIP LENGTHS FOR ANY JOB

**BUY ONE OR IN BULK**

QUANTITY DISCOUNTS AVAILABLE



**PANELfast**

VIEW OUR ENTIRE LINE OF FASTENERS @

**PANELFAST.COM**

TOLL FREE: **877-372-2348**

**PANELfast**

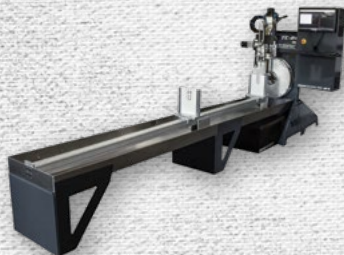

## SHOPSABRE CNC TUBE CUTTER (TC) SERIES

- Available in 12-foot and 24-foot processing configuration
- Precision cutting: Designed for round, square, and rectangular tubes
- High efficiency: Streamline production with advanced automation
- Heavy-duty construction: Built to withstand demanding environments
- Versatile applications: Ideal for automotive, custom fabrication, and decorative design
- Made in the USA: Ensures unmatched quality and durability

Contact: 952-461-4570

[shopsabre.com](http://shopsabre.com)



## STKR CONCEPTS UNDERHOOD FLEXIT MECHANICS LED WORK LIGHT

- Light up your engine bay with this flexible light source
- Folds into a compact size, yet stretches to over 6 ft.
- 1000 Lumen flexible LED band
- Expandable to 6 ft.
- 160° Rotation
- Adjustable straps and magnetic base
- Rechargeable

Contact: 704-508-1031

[b2b.stkrconcepts.com](http://b2b.stkrconcepts.com)



## SUPERIOR BEARING & SUPPLY HIGH SPEED MACHINE TOOL SPINDLE BEARINGS

- Superior Bearing supplies high-speed machine tool spindle bearings from all the top premium brands
- Whether you're an OEM or machine user, your production and maintenance needs are covered
- Full-service bearing house that stocks bearings for everything that moves
- Contact us for quality solutions today

Contact: 800-423-5318

[superiorbearings.com](http://superiorbearings.com)



## THREAD KITS CO. THREAD REPAIR PRODUCTS

- Perma-Coil
- Perma-Kee
- Perma-Rivet
- Time-Sert
- Big-Sert

Contact: 310-891-1995

[threadkits.com](http://threadkits.com)



**TIERRA TECH USA**  
**ULTRASONIC CLEANER**  
**MOT-600N**

- Advanced ultrasonic technology
- Utilizes high-frequency sound waves for deep cleaning
- Removes contaminants such as oil, grease, carbon deposits, rust, and residues

Contact: 956-584-2277  
[tierratech.com](http://tierratech.com)



**WALTON CO.**  
**WALTON TAP EXTRACTORS**

- Remove broken taps without drilling, lasers, damaged threads, scrapped parts, or repair inserts
- And save the threads!
- Available in every tap size—both inch and metric—as handy sets
- Or available as individual pieces
- Proudly made in the USA

Contact: 860-523-5231  
[wالتونتولز.com](http://wالتونتولز.com)



IT STARTS IN THE SHOP.  
 IT ENDS IN VICTORY LANE.

Engine builders are perfectionists. And so are MAHLE Motorsport engineers. Expect unmatched performance, absolute tolerances and proven durability from every piston. And if you order a POWERPAK piston kit, you also get low-drag piston rings, clips and steel pins—all designed to complement your pistons to ensure minimum friction and maximum horsepower.

**POWERPAK**

**MAHLE**  
 Motorsport

**MAHLE**  
 Motorsport

**BUILD SOMETHING GREAT**  
[MAHLEmotorsport.com](http://MAHLEmotorsport.com)

**MAHLE**  
 Motorsport

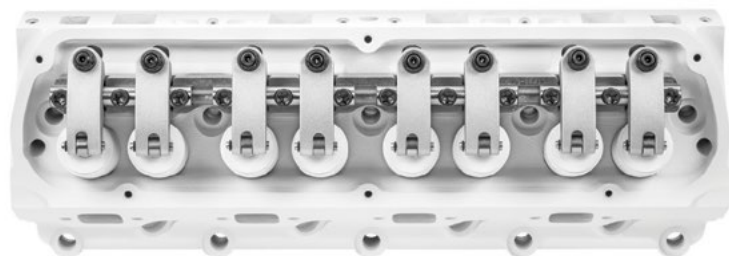

**SPORTSMAN ALUMINUM SHAFT ROCKERS**



Designed for naturally aspirated applications, Jesel Sportsman Series rocker systems have proven themselves to be the ultimate replacement for inadequate stud rocker assemblies on OEM and aftermarket cylinder heads. No modification. No aggravation.

For additional product details, visit us online at [Jesel.com](http://Jesel.com) or contact us by phone at 732.901.1800



SECTION

5

# RACE TRACK EQUIPMENT

The off-season can be a welcome break for track promoters who seek to tune up their programs after the final checkered flag falls for the year. Use this section to find new vendors for concessions, track equipment, maintenance, and more.



# SAVE THE DATE!

DEC. 11-13, 2025

DON'T MISS  
OUT ON THE  
3 BIGGEST  
DAYS IN  
MOTORSPORTS

**PRI**SHOW

INDIANAPOLIS, INDIANA | INDIANA CONVENTION CENTER

# RACECEIVER

raceceiver.com | 770-287-8544



## TRACK LIGHTS

- Wireless corner lights
- Battery or AC
- Full track control
- Works with LITEceiver Race Control
- Easy mounting
- Three color: red, green, yellow
- Long-range radio
- Integrates with existing lights
- P67 and IP69K Water and dust proof



## LITECEIVER IMPACT

- Impact G-Forces
- Wireless flagging
- Control the entire field with a simple button press
- Simple, rugged, and rechargeable
- Rollbar mounted
- Bright flag status LEDs
- Long-range radio
- Extended range repeater option
- Encrypted channels
- The circle track, karting, and offshore solution



## CLASSIC FUSION +

- The gold standard in communication
- Button lock
- Louder audio
- Narrow band radio compatible
- Race officials broadcast directly to drivers
- Allows faster line-ups and restarts
- Instant notifications of track conditions
- Coaches provide instant feedback
- Improves skills and overall performance
- Motivate with supportive statements for good performance



## LITECEIVER

- Wireless flagging
- Control the entire field with a simple button press
- Simple, rugged, and rechargeable
- Roll bar mounted
- Bright flag status LEDs
- Long-range radio
- Extended range repeater option
- Encrypted channels
- The circle track, karting, and offshore solution



**BUFFALO TURBINE  
CYCLONE SQUARED**

- Buffalo Turbine has manufactured high-powered debris blowers since 1945
- The most popular model found for clearing debris from race tracks is the dual-turbine Squared blower
- With twice the volume of the KB7 blower, this unit will clear surfaces fast and get the surface back to racing

Contact: 716-592-2700  
[buffaloturbine.com](http://buffaloturbine.com)



**FOD CONTROL CORPORATION  
FOD-RAZOR MOTORSPORT  
SWEEPER**

- The solution you've been looking for
- FOD-Razor MotoSweep helps maintenance crews keep their motor speedway facilities safe and event-ready
- Eliminates foreign object debris (FOD) on tracks, pit roads, parking areas, and adjacent surfaces

Contact: 800-425-8363  
[fodcontrol.com](http://fodcontrol.com)



**GEARHEAD COFFEE  
GEARHEAD COFFEE**

- Elevate your automotive and motorsport experiences with Gearhead Coffee's bold, flavorful roasts
- The perfect coffee solution for any track, off-road park, or garage
- Carefully sourced beans that deliver a rich and satisfying taste that's perfect for fueling your day
- Looking for a customized coffee solution? Contact us today to explore options for concessions, VIP suites, and lounges

Contact: 214-542-6008  
[gearheadcoffee.com](http://gearheadcoffee.com)



**RAXWELL  
LIGHTWEIGHT UNIVERSAL  
ABSORBENT PADS**

- Provide reliable spill control for industrial settings
- Designed to quickly absorb oils, coolants, solvents, and water
- Durable, tear-resistant construction and a low-lint design, ensuring a clean workspace
- Ideal for machine shops and maintenance areas, these pads offer efficient and long-lasting performance

Contact: 949-414-9977  
[raxwellindustries.com](http://raxwellindustries.com)

**Motive  
Gear**

MOTIVEGEAR.COM

**COMPLETE  
FRONT AND REAR KITS  
FOR JEEP TJ-JK**



TENFACTORY.COM

**PERFORMANCE AXLE KITS**



**CHROMOLY DRIVESHAFTS**





SECTION

6

# RACE SANCTIONING ORGANIZATIONS

These motorsports governing bodies develop and enforce rulebooks while they partner with member tracks, penalize infractions, operate sponsorship and contingency programs, manage payouts, and strive to keep drivers, crew members, spectators, and others safe.

**24 HOURS OF LEMONS**

1015 Cedar St.  
Santa Cruz, CA 95060  
844-288-8227  
nick@24hoursoflemons.com  
24hoursoflemons.com

**REGION:** USA

**TYPE:** Endurance Races For \$500 Cars, Car Shows, Road Rallies, Sim Racing

**500 SPRINT CAR TOUR**

1311 Martin Luther King Jr. Blvd.  
Anderson, IN 46016  
765-642-0206  
jowen@andersonspeedway.com  
500sprintcartour.com

**REGION:** IN, MI, OH

**TYPE:** Non-wing Pavement Sprint Cars

**AMERICAN CANADIAN TOUR (ACT)**

105 N. Main St., Ste. 203  
PO Box 1002  
Barre, VT 05641  
802-244-6963  
info@acttour.com  
acttour.com

**REGION:** CT, MA, ME, NH, VT, and QC, Canada

**TYPE:** Late Models, 604 Mods, Light Modifieds, Street Stocks, Mini Stocks

**AMERICAN DRAG RACING LEAGUE**

204 W. Pitman St., Ste. E  
O'Fallon, MO 63366  
636-542-8400  
info@adrlltour.com  
adrlltour.com

**REGION:** AL, GA, TX

**TYPE:** Drag Racing

**AMERICAN LATE MODEL  
IRON-MAN SERIES**

PO Box 590  
Somerset, KY 42502  
828-361-5981  
tilleyracing@gmail.com  
imdir.net

**REGION:** IN, KY, MI, OH

**TYPE:** Dirt Late Model Racing

**AMERICAN RALLY  
ASSOCIATION (ARA)**

4910 W. 16th St.  
Speedway, IN 46224  
317-247-5151  
ara@ara-rally.com  
americanrallyassociation.org

**REGION:** MI, MN, MO, OH, OR, TN, WA

**TYPE:** United States Stage Rally Racing, 501(c) (3) Nonprofit

**AMERICAN SPRINT CAR SERIES (ASCS)**

7575-D Westwinds Blvd.  
Concord, NC 28027  
918-607-6893  
lwheatley@dirtdcar.com  
ascsracing.com

**REGION:** AL, AR, FL, IA, KS, OK, TX

**TYPE:** 360 Sprint Car Racing

**ATLANTIC COAST OLD TIMERS AUTO  
RACING CLUB**

193 Thompson Rd.  
Windsor, NY 13865-1345  
607-655-1427  
johnjwaples@gmail.com  
acotnews.org

**REGION:** ME, NY, PA

**TYPE:** Antique Race Cars

**AUSTRALIAN NATIONAL DRAG RACING  
ASSOCIATION**

287 Payneham Rd.  
Royston Park, SA 5070  
Australia  
08-8271-5355  
info@andra.com.au  
andra.com.au

**REGION:** Australia

**TYPE:** Drag Racing

**AUTO VALUE BUMPER TO BUMPER SUPER  
SPRINTS**

109 N. Broadway  
Cassopolis, MI 49031  
269-580-2461  
tom@supersprints.com  
supersprints.com

**REGION:** MI, OH

**TYPE:** 410 Asphalt Winged Sprint Car Racing

**AUTOMOBILE COMPETITION COMMITTEE  
US/FIA (ACCUS)**

825 Ballough Rd., Ste. 200-C  
Daytona Beach, FL 32114  
386-506-0140  
accusfia.us

**REGION:** USA

**TYPE:** International Sporting Sanctioning Authority For The US

**AUTOMOBILE RACING CLUB  
OF AMERICA (ARCA)**

PO Box 380  
Temperance, MI 48182  
734-847-6726  
jaharris@arcaracing.com  
arcaracing.com

**REGION:** USA

**TYPE:** Stock Cars

**BADGER MIDGET AUTO RACING  
ASSOCIATION**

2764 Egge Rd.  
Sun Prairie, WI 53590  
847-840-1344  
info@bmara.com  
bmara.com

**REGION:** IL, WI

**TYPE:** Midget Racing

**BAY CITIES RACING ASSOCIATION (BCRA)**

2218 Bluffs Ct., Livermore, CA 94551  
510-376-3338  
bcraracing@gmail.com  
bcraracing.com

**REGION:** CA

**TYPE:** Midgets Racing, Lightning Sprints & Vintage Division

**BEST IN THE DESERT**

3475 Boulder Hwy., Ut. B  
Las Vegas, NV 89121  
702-457-5775  
bitd@bitd.com  
bitd.com

**REGION:** NV, AZ

**TYPE:** Off-Road Racing

**BIG 8 LATE MODEL SERIES**

PO Box 1000, Rockford, IL 61105  
815-633-1500  
info@big8latemodels.com  
big8latemodels.com

**REGION:** IA, IL, WI

**TYPE:** Short Track

**BMW CAR CLUB OF AMERICA**

2350 Highway 101 S.  
Greer, SC 29651  
864-250-0022  
kchulkas@bmwcca.org  
bmwccaclubracing.com  
**REGION:** USA  
**TYPE:** Car Club

**BUCKEYE OUTLAW SPRINT SERIES (BOSS)**

2177 Lunbeck Rd.  
Chillicothe, OH 45601  
740-703-3768  
sprinter14@hotmail.com  
bossfastsprints.com  
**REGION:** IN, OH, PA  
**TYPE:** Sprint Cars

**CALIFORNIA LIGHTNING SPRINTS**

24325 Crenshaw Blvd., #146  
Torrance, CA 90505  
sdaloisiosports@gmail.com  
racecls.com  
**REGION:** CA  
**TYPE:** Sprint Cars

**CANADIAN AUTOMOBILE SPORT CLUBS - ONTARIO (CASC-OR)**

7250 Keele St., Ste. 413  
Concord, ON L4K 1Z8  
Canada  
416-667-9500  
office@casc.on.ca  
casc.on.ca  
**REGION:** ON, Canada  
**TYPE:** Sports Car Racing

**CAROLINA CLASH SUPER LATE MODEL SERIES**

129 Oakvale Dr.  
Easley, SC 29640  
864-238-2254  
marion@carolinaclash.com  
carolinaclash.com  
**REGION:** NC, SC  
**TYPE:** Dirt Super Late Model Racing

**CAROLINA SPRINT TOUR**

484-576-6470  
carolinasprinttour@yahoo.com  
facebook.com/CarolinaSprintTour/  
**REGION:** NC, SC  
**TYPE:** Winged 305 Sprint Car Racing

**CARS RACING TOUR**

349 Cayuga Dr., Mooresville, NC 28117  
704-662-9212  
info@carsracingtour.com  
carsracingtour.com  
**REGION:** NC, SC, VA  
**TYPE:** Super Late Models, Late Model Stock Cars

**CHAMPCAR ENDURANCE SERIES**

PO Box 16, Piney River, VA 22964  
434-996-6721  
info@champcar.com  
champcar.org  
**REGION:** USA  
**TYPE:** Endurance Road Racing

**CHAMPIONSHIP OFF-ROAD**

6600 Jansen Ave. NE, PO Box 167  
Albertville, MN 55301  
763-497-8474  
info@champofoffroad.com  
champofoffroad.com  
**REGION:** MI, MN, WI  
**TYPE:** Off-Road Racing

**CHAMPION RACING ASSOCIATION**

PO Box 41426, Nashville, TN 37204  
812-883-0455  
lucett@cra-racing.com  
cra-racing.com  
**REGION:** GA, IN, MI, OH, TN  
**TYPE:** ASA Stars National Tour, ASA Midwest Tour, ASA Southern Super Series, JEGS/CRA All-Stars Tour, Vores Welding & Steel Late Model Sportsman Series, CRA Street Stock Series

**COMMISSION INTERNATIONALE DE KARTING-FIA (CIK-FIA)**

2 chemin de Blandonnet  
1215 Geneve 15, Switzerland  
41 0 22 306 1080  
fiakarting.com  
**REGION:** Europe  
**TYPE:** Karting

**COMP CAMS SUPER DIRT SERIES**

802 Third Ave.  
Conway, AR 72032  
sully1888@gmail.com  
compdirt.com  
**REGION:** AR, KS, LA, MS  
**TYPE:** Super Late Model Racing in the South

**CRATE RACIN' USA**

PO Box 195  
Lincoln, AL 35096  
678-719-8888  
crateracinusa@gmail.com  
crateracinusa.com  
**REGION:** AL, FL, GA, KY, LA, MS, TN, TX  
**TYPE:** Crate Motor Dirt Late Model Racing

**CRS SUPER TRUCK SERIES**

14340 Gaskill Dr. NE  
Alliance, OH 44601  
216-217-5038  
coyotebilly26@yahoo.com  
crssupertruckseries5.godaddysites.com  
**REGION:** IN, MI, NC, OH, WV  
**TYPE:** Pickup Truck/Ute Racing

**DIRTCAR RACING**

7575-D Westwinds Blvd.  
Concord, NC 28027  
704-795-7223  
info@dirtcars.com  
dirtcars.com  
**REGION:** USA  
**TYPE:** Dirt Late Model Series

**EMPIRE SUPER SPRINTS (ESS)**

91 Ellen St.  
Oswego, NY 13126  
315-342-3933  
chuckm@empiresupersprints.com  
empiresupersprints.com  
**REGION:** NY, and ON, QC, Canada  
**TYPE:** Winged 360 Sprint Car Racing

**ENGLEWOOD RACING ASSOCIATION**

7473 W. Laurel Ave.  
Littleton, CO 80128  
303-947-8806  
erasupermodifieds.wix.com/home  
**REGION:** CO  
**TYPE:** Super Modifieds

**FASTRAK RACING SERIES**

312 Greens Crossing Rd.  
Richmond, KY 40475  
859-893-7627  
office@fastrakracing.com  
fastrakracing.com  
**REGION:** GA, NC, PA, VA, WV  
**TYPE:** Crate Late Models, Dirt Late Models, Super Late Models

**FEDERATION INTERNATIONALE DE L'AUTOMOBILE (FIA)**

8 place de la Concorde  
75008 Paris  
France  
+33-1-4312-44-55  
fia.com

**REGION:** Worldwide

**TYPE:** Formula 1, Formula E, World Rally

**FLORIDA POWERBOAT CLUB**

1214 SW 6th St.  
Pompano Beach, FL 33069  
954-545-1414  
admin@flpowerboat.com  
flpowerboat.com

**REGION:** AL, FL, and Bahamas

**TYPE:** High Performance Speed Boats

**FORMULA DRIFT**

2161 Gundry Ave.  
Signal Hill, CA 90755  
562-901-2600  
info@formulad.com  
formulad.com

**REGION:** USA, Canada, Japan

**TYPE:** Drifting

**FORMULA PRO USA WESTERN CHAMPIONSHIPS**

711 S. Carson St., Ste. 4  
Carson City, NV 89701  
888-977-7885  
info@exclusiveracing.com

formulaprousa.com

**REGION:** CA

**TYPE:** Open Wheel Road Racing

**FORMULA RACE CAR CLUB OF AMERICA (FRCCA)**

160 Flying Point Rd.  
Freeport, ME 04032  
201-665-8682  
frcca2014@gmail.com  
formularacecarclubofamerica.com

**REGION:** MA, NY

**TYPE:** Formula Car Racing

**FORMULA RACE PROMOTIONS**

1 Stiles Rd., Ste. 105  
Salem, NJ 03079  
855-722-3377  
formularacepromotions.com

**REGION:** CT, GA, NJ, OH, PA, WI, WV

**TYPE:** Formula Car Racing

**NEW**

**BBC 20-degree Cylinder Head**

**HELLFIRE  
PRO-FILER**



Part No. PBM521-X-C43-03

Fully CNC Ported

438cc Intake Runners

95cc Combustion Chambers

2.400/1.800 Valves

Copper Alloy Seats

Manganese Bronze Guides



The New Pro-Filer HellFire features unbeatable casting quality with a full CNC porting program. The 20° valve angle and a highly efficient 95cc combustion chamber, combined with high flowing 438cc intake runners produce outstanding performance.



Distributed Exclusively By  
**PBM Performance Products**

[www.pbm-erson.com](http://www.pbm-erson.com)

**800-588-9608**

Louisville, KY  
800-879-1325

Urbandale, IA  
800-400-0850

Barboursville, WV  
800-879-6233

St. Peters, MO  
800-625-5900

Laurel, MD  
800-578-4182

Greensboro, NC  
800-879-0230

**H-P** H-P Products  
Engineered Tube Bends

**YOUR ONE-STOP SHOP FOR  
TUBE BENDING &  
FABRICATION**

CNC BENDING / LASER TUBE CUTTING /  
END FORMING / WELDING

CONTRACT + PRIVATE LABEL  
MANUFACTURING

H-PTUBEBENDS.COM | 800-860-8823



# BUILT FOR THE BUILDER

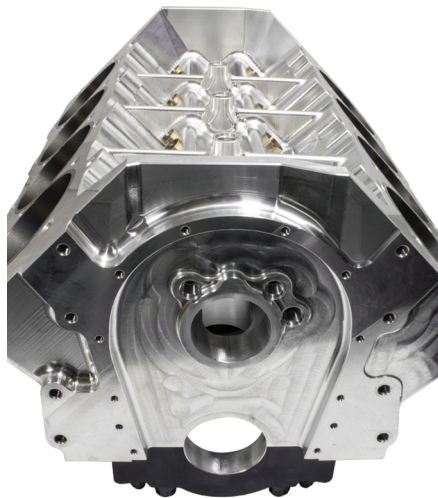

**Included in every block:**

- Honed Crankshaft Mains
- Honed Camshaft Tunnel
- Bored Cylinder Sleeves
- Cylinder Sleeve Protrusion

**419-355-9304**

# ENERGY

**MADE IN THE USA**

SECTION

6

RACE SANCTIONING  
ORGANIZATIONS

### GLOBAL TIME ATTACK

2170 W. 190th St.  
Torrance, CA 90504  
562-999-4670  
info@globaltimeattack.com  
globaltimeattack.com  
**REGION:** USA  
**TYPE:** Time Attack

### GOODGUYS ROD & CUSTOM ASSOCIATION

PO Box 1932, Roanoke, TX 76262  
800-777-1258  
good-guys.com  
**REGION:** USA  
**TYPE:** Goodguys Autocross Series

### GRAND NATIONAL SUPER SERIES

704-660-1280  
infoatgnss@gmail.com  
grandnationalsuperseries.com  
**REGION:** NC, PA, VA  
**TYPE:** Stock Car Racing

### HIGH LIMIT RACING

info@highlimitracing.com  
highlimitracing.com  
**REGION:** USA  
**TYPE:** Winged 410 Sprint Cars

### HISTORIC SPORTSCAR RACING (HSR)

One Daytona Blvd.  
Daytona Beach, FL 32114  
386-681-5535  
info@hsrrace.com  
hsrrace.com  
**REGION:** USA  
**TYPE:** Vintage & Historic Road Racing

### INDYCAR

4551 W. 16th St.  
Indianapolis, IN 46222  
317-492-6526  
indycar@indycar.com  
indycar.com  
**REGION:** USA  
**TYPE:** NTT IndyCar Series and Indy NXT

### INTERNATIONAL HOT ROD ASSOCIATION

PO Box 386  
House Springs, MO 63051  
855-646-4472  
info@ihra.com  
ihra.com  
**REGION:** Worldwide  
**TYPE:** Drag Racing

### INTERNATIONAL KART FEDERATION (IKF)

33175 Temecula Pkwy., Ste. 233  
Temecula, CA 92592  
951-491-0808  
info@ikfkarting.com  
ikfkarting.com  
**REGION:** USA  
**TYPE:** Kart Racing

### INTERNATIONAL MOTOR CONTEST ASSOCIATION (IMCA)

PO Box 921  
Vinton, IA 52349  
319-472-2201  
raceimca@imca.com  
imca.com  
**REGION:** USA and Canada  
**TYPE:** Modifieds, Sport Modifieds, Late  
Model, Sprint, Stock, Compacts

### INTERNATIONAL MOTOR SPORTS ASSOCIATION (IMSA)

One Daytona Blvd.  
Daytona Beach, FL 32114  
386-310-6500  
info@imsa.com  
imsa.com  
**REGION:** USA and Canada  
**TYPE:** WeatherTech SportsCar  
Championship, Michelin Pilot Challenge,  
Porsche Carrera Cup North America,  
Ferrari Challenge, Lamborghini Super  
Trofeo North America, Mustang Challenge,  
and VP Racing SportsCar Challenge

### IRA OUTLAW SPRINT SERIES

706 Green St.  
McHenry, IL 60050  
815-759-9269  
siraprez@sbcglobal.net  
irasprints.com  
**REGION:** IA, IL, IN, MN, ND, WI  
**TYPE:** 410 Winged Sprints, Wisconsin  
Wingless Sprints

### ISMA/MSS SUPERMODIFIED SERIES

PO Box 5157  
Oswego, NY 13126  
315-236-0205  
jessica.ordway@hotmail.com  
ismasupers.com  
**REGION:** MI, NC, NH, NY, OH  
**TYPE:** Winged Super Modifieds



### KAJUN MINI STOCKS ASSOCIATION

1209 Highway 35  
Pelham, AL 35124  
865-335-4518  
kajunministocks321@gmail.com  
facebook.com/p/Kajun-Mini-Stocks-100060851964504/

**REGION:** USA

**TYPE:** Modified Four-cylinder Stock Cars

### KIDMODZ RACING SERIES

618-314-3596  
kidmodz@sbcglobal.net  
facebook.com/kidmodz/

**REGION:** IL, MO

**TYPE:** Dirt Oval Youth Racing

### KINGMAN ROUTE 66 STREET DRAGS

3880 Stockton Hill Rd., Ste. 103-428  
Kingman, AZ 86409  
928-279-9845

kingmanstreetdrags@gmail.com

kingmanrt66streetdrags.com

**REGION:** AZ

**TYPE:** Drag Racing

### LUCAS OIL LATE MODEL DIRT SERIES

299 Haskell Ln., Ut. C-6  
Batavia, OH 45103  
951-403-1609  
rick@lucasdirt.com  
lucasdirt.com

**REGION:** USA

**TYPE:** Dirt Late Models

### LUCAS OIL MIDWEST LATE MODEL RACING ASSN (MLRA)

18842 Speedway Dr.  
PO Box 8  
Wheatland, MO 65779  
417-282-5984  
ernie@lucasoil.com  
mlraracing.com

**REGION:** Midwest USA

**TYPE:** Dirt Late Models

### LUCKY DOG RACING SERIES

1155-C Arnold Dr., Ste. 365  
Martinez, CA 94553  
844-585-9364  
info@racelucky.com  
racelucky.com

**REGION:** USA

**TYPE:** North American Amateur Endurance Racing Series

# UNITED

## RACE PARTS®

PIT EQUIPMENT HEADQUARTERS

## FEATURED PRODUCTS

### DP6000-LH SPLINE



Paoli's patented spline drive has now been applied to the DP6000. Increased socket engagement offers more torque and smoother operation.

### SEAMLESS GARAGE WALLING



Seamless aluminum garage & hospitality walling. Completely customizable to your layout needs with graphics, LED's, logo lights, TV's, storage, doorways and more.

### 200L FUEL BOWSER



Accurately pump fuel in and out of the car or fuel rig. The built in load cells integrate with the Greaves Fuel Timer Management Software.

North America's exclusive distributor and service center for:



+1.704.500.2000 // [f](#) [t](#) [i](#)  
UnitedRaceParts.com

VISIT US AT **PR**I BOOTH #915

# LS Chevy Swap, Pan Kit



- Saves space over cast oil pans
  - Shorter at 5½" deep
  - Saves ½" depth in the front over a cross member
  - Saves ¾" from the front of the sump to any steering
- 6 quart pan capacity, ½ quart more than cast pans
- Allows use of long LS filter without hanging below the pan
- If your engine has a stroker crank, aftermarket heads or even a turbo, don't just get "a" pan. Get one that will allow your engine and chassis to perform at 100% and is really up to the level of your build!



Kit includes pan, pickup, filter boss and bolts .....#30917-1



Visit Milodon on the web for additional information:

[www.milodon.com](http://www.milodon.com)  
Simi Valley, CA • (805) 577-5950



# NEO SYNTHETIC GEAR OILS

Ph: 1-562-595-7208  
Email: Neooilusa@gmail.com

[NeoSyntheticoil.com](http://NeoSyntheticoil.com)

## SECTION 6 | RACE SANCTIONING ORGANIZATIONS

### MASTERS HISTORIC RACING

35A Market Pl.  
Olney, Bucks MK46 4AJ  
United Kingdom  
+44 (0) 1234-713800  
team@mastershistoricracing.com  
mastershistoricracing.com  
**REGION:** USA and Europe  
**TYPE:** Historic Motor Racing

### MAVERICK WINGED SPRINT SERIES

1051 W. US Highway 40  
Greencastle, IN 46135  
info@mavericksprints.com  
facebook.com/p/Maverick-Winged-Sprint-Series-61551120872643/  
**REGION:** IN  
**TYPE:** 410 Winged Sprint Cars

### MID-WEST DRAG RACING SERIES

918-897-1194  
keith@midwestpromodseries.com  
midwestdragracingseries.com  
**REGION:** AR, IL, KS, MI, MO, TX  
**TYPE:** Pro Mod Drag Racing

### MIDWEST OPEN WHEEL ASSOCIATION

PO Box 584  
Jacksonville, IL 62651  
217-371-3653  
mowasprints@gmail.com  
midwestopenwheel.com  
**REGION:** Midwest USA  
**TYPE:** 410 Winged Sprint Cars

### MIDWEST SPRINT TOURING SERIES

1200 N. Cliff Ave.  
Sioux Falls, SD 57103  
605-336-9112  
msts360.com  
**REGION:** IA, MN, NE, SD  
**TYPE:** Winged Sprint Car Racing

### MIDWEST SUPER COMP SERIES

11855 Cormoy Ln.  
Orland Park, IL 60467  
630-201-0365  
midwestsupercomp.com  
**REGION:** IA, IL, IN, MI, WI  
**TYPE:** Super Comp Drag Racing

### MIDWESTERN COUNCIL OF SPORTS CAR CLUBS

2410 Royal Ct., Waukesha, WI 53188  
262-442-6073  
president@mcscc.org  
mcscc.org  
**REGION:** IL, MI, WI  
**TYPE:** Sports Car Racing

### MODIFIED RACING SERIES

11 Bonney Shores Rd.  
Meredith, NH 03253  
603-707-0526  
viperracing2@gmail.com  
themodifiedracingseries.com  
**REGION:** CT, ME, NH  
**TYPE:** Asphalt Modified Racing

### MONACO MODIFIED TRI-TRACK SERIES

1098 Fall River Ave.  
Seekonk, MA 02771  
508-336-8307  
info@monacomodifieds.com  
monacomodifieds.com  
**REGION:** CT, MA, NH, VT  
**TYPE:** Asphalt Modified Racing

### MUST SEE RACING SPRINT SERIES

11255 Glen Hill Ln., Holly, MI 48442  
248-762-1732  
hmsinc98@aol.com  
msrxxtreme.com  
**REGION:** USA  
**TYPE:** Pavement Winged Sprints

### NATIONAL ASSOCIATION FOR STOCK CAR AUTO RACING (NASCAR)

One Daytona Blvd.  
Daytona Beach, FL 32114  
800-630-0535  
cs\_escalations@nascar.com  
nascar.com  
**REGION:** USA, Canada, Mexico, Europe  
**TYPE:** Stock Car Racing

### NATIONAL ASSOCIATION OF DIESEL MOTORSPORTS (NADM)

PO Box 188  
Smithville, MO 64089  
816-810-6287  
ronk@dieselmotorsports.us  
dieselmotorsports.us  
**REGION:** USA  
**TYPE:** Diesel Motorsports: Sled Pulling, Drag Racing, Dyno Competition, 4x4

### NATIONAL AUTO SPORT ASSOCIATION (NASA)

7065 W. Ann Rd. #130-432  
Las Vegas, NV 89130  
510-232-6272  
help@drivenasa.support  
drivenasa.com

**REGION:** USA

**TYPE:** HPDE, NASA-X, Time Trial, Rally Sport, Road Racing

### NATIONAL ELECTRIC DRAG RACING ASSOCIATION

info@nedra.com  
nedra.com

**REGION:** USA, Canada, Europe, Australia/New Zealand

**TYPE:** Electric Vehicle Drag Racing

### NATIONAL HOT ROD ASSOCIATION (NHRA)

104 Via Verde, Ste. 100  
San Dimas, CA 91773  
626-914-4761  
nhra@nhra.com  
nhra.com

**REGION:** USA

**TYPE:** Championship Drag Racing

### NATIONAL OPEN WHEEL 600 SERIES

PO Box 389, Drumright, OK 74030  
918-417-0624  
now600series@gmail.com  
now600series.com

**REGION:** FL, IL, KS, MO, NE, OK, TX

**TYPE:** 600 Micro Sprints

### NATIONAL TRACTOR PULLERS ASSOCIATION (NTPA)

6155-B Huntley Rd.  
Columbus, OH 43229-1061  
614-436-1761  
info@ntpapull.com  
ntpapull.com

**REGION:** USA

**TYPE:** Truck & Tractor Pulling

### NITROCROSS

Thrill One Entertainment  
6650 S. Torrey Pines Dr.  
Las Vegas, NV 89118  
info@thrillone.com  
nitrocrossracing.com

**REGION:** USA and Canada

**TYPE:** Rallycross

# NEW 3000cc Injector

# IT'S BIG!

And Compatible With All Fuels.

Scan for info.



Visit us at PRI • Booth 609

[fuelinjectorclinic.com](http://fuelinjectorclinic.com) • 561.427.0082

**FIC**  
FUEL INJECTOR CLINIC

## GET HEMI CNC PERFORMANCE WITHOUT BREAKING THE BANK

AFR IS EXCITED TO ANNOUNCE A NEW OFFERING FOR 5.7L - 6.1L MODERN HEMI OWNERS! THIS CYLINDER HEAD IS A COMBINATION OF OUR ENFORCER SERIES AND OUR EXTENSIVE CNC PROGRAM.

As you know, AFR's 185cc Enforcer Hemi Cylinder Heads already feature an amazing port design using an As-Cast Permanent-Mold technology. We've taken it a step further and CNC ported those Enforcer Heads so you can enjoy peak performance without breaking the bank. You can order our NEW 195cc Street Hawk Hemi Cylinder Heads complete or without parts.

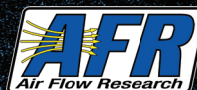

**STREET HAWK**  
195CC GEN III HEMI CYLINDER HEADS BY AIR FLOW RESEARCH

For a complete list of AFR Gen III Hemi cyl. head models and specifications, scan this QR code or visit our website at [airflowresearch.com](http://airflowresearch.com)



**Tired of  
Running  
Hot?**

**Call Today!  
1-800-842-5166**

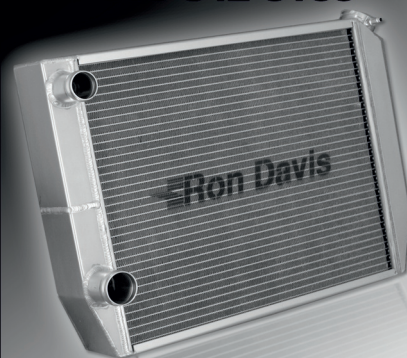

**Ron Davis**  
RACING PRODUCTS  
High Performance Radiators

All Types of Racing  
Lightweight Aluminium Construction  
Pressure Tested at 30 PSI  
Furnace Brazed Cores  
100% Tig Welded  
6061-T6 Outlets

Glendale, Arizona



[RonDavisRadiators.com](http://RonDavisRadiators.com)

**Must have Merch  
for Racing Teams and Fans!**



2025  
Wall  
Calendars  
\$6

**CALVERT  
RACING**  
3'x1'  
Vinyl Banner, \$20

24"x70"  
Roll Up  
Cushioned  
Pit Mat, \$40

Apparel  
Starting  
at \$20



Stocking  
Stuffer  
Merch  
starting  
at \$5



Out of ideas??  
Calvert Racing Gift  
Certificates - Any Amount

**Merry Christmas!**  
**CALVERT  
RACING**

ASK A TECH:

**661-728-9600**

Hours: M-F 8am-4:30pm PST

[CalvertRacing.com](http://CalvertRacing.com)

2024 Holiday

### NORTH STATE MODIFIED SERIES

6131 E. Highway 20  
Lucerne, CA 95458  
707-274-1662  
28arpy@dmchsi.com  
facebook.com/northstatedmodifieds  
**REGION:** CA  
**TYPE:** Modified Racing

### NORTHEASTERN MIDGET ASSOCIATION (NEMA)

10 Kendrick Ln.  
Pocasset, MA 02559  
917-435-8522  
secretary@nemaracing.com  
nemaracing.com  
**REGION:** Northeast US  
**TYPE:** Midget Racing

### NORTHERN AUTO RACING CLUB (NARC)

4299 O'Connor Way  
Sacramento, CA 95838  
714-397-7417  
info@narc410.com  
narc410.com  
**REGION:** CA  
**TYPE:** Winged 410 Sprint Car Races

### NORTHERN LATE MODEL RACING ASSOCIATION (NLRA)

2147 17th St. NE  
Grand Forks, ND 58203  
701-740-5201  
nlraracing@gmail.com  
nlra.org  
**REGION:** MN, ND, SD  
**TYPE:** Dirt Late Model Racing

### NOSTALGIA DRAG RACING LEAGUE (NDRL)

480 Town Center Rd. N., #260  
Mooresville, IN 46158  
314-517-4455  
nostalgialeague.com  
**REGION:** USA  
**TYPE:** Pro 7.0, Pro 7.50, Pro Comp and  
Pro Gas

### NOSTALGIA SUPER STOCK

262-844-2111  
nostalgiasuperstock.com  
rberlisk@wi.rr.com  
**REGION:** USA  
**TYPE:** Drag Racing Super Stock Cars of  
the 1960s

### OHIO WHEELMAN SUPER SERIES

440-731-4654  
webmaster@ohiowheelmanseries.com  
ohiowheelmanseries.com  
**REGION:** IN, MI, OH, PA  
**TYPE:** Modifieds and Super Stocks

### OIL CAPITAL RACING SERIES

412 E. 6th St., Caney, KS 67333  
918-636-0336  
tkent7979@gmail.com  
ocrsracing.net  
**REGION:** KS, MO, OK, TX  
**TYPE:** Sprint Car Racing

### OUTLAW DIESEL SUPER SERIES

4960 N. 13th St., Terre Haute, IN 47805  
812-241-8541  
info@outlawdieselss.com  
outlawdieselss.com  
**REGION:** USA  
**TYPE:** Diesel Drag Racing, Diesel Pulling

### OUTLAW STREET CAR ASSOCIATION

270-452-9085  
oscaseries@gmail.com  
outlawstreetcars.com  
**REGION:** AL, KY  
**TYPE:** Drag Racing

### OUTLAW TRUCK & TRACTOR PULLING ASSOCIATION

745 Riverview Dr.  
Rock Valley, IA 51247  
712-470-1593  
contact@outlawpulling.com  
outlawpulling.com  
**REGION:** USA  
**TYPE:** Outlaw Truck and Tractor Pulling

### OZARK MOUNTAIN SUPER SHIFTERS

309-853-2626  
jlclabough91@gmail.com  
ozarkmountainsupershifters.com  
**REGION:** Midwest  
**TYPE:** Drag Racing

### PORSCHE CLUB OF AMERICA

PO Box 6400  
Columbia, MD 21045  
410-381-0911  
admin@pca.org  
pca.org  
**REGION:** USA and Canada  
**TYPE:** Car Club

### PORSCHE OWNERS CLUB

1968 S. Coast Highway, #4911  
Laguna Beach, CA 92651  
619-630-0673  
marketing@porscheclub.com  
porscheclub.com  
**REGION:** CA  
**TYPE:** Car Club

### POWRi RACING

8939 Bevo Ct.  
Belleville, IL 62223  
314-267-4944  
kbrown@powri.com  
powri.com  
**REGION:** USA  
**TYPE:** Open Wheel, National Midgets,  
Micros, Sprints

### PREMIER STREET CAR ASSOCIATION

661-917-3078  
mel@racepsca.com  
racepsca.com  
**REGION:** NV  
**TYPE:** Heads-up, Index & Bracket Racing,  
Vegas Show Series, Vendors Midway

### PRO ALCOHOL DRAG RACING (PADR)

padr1320.com  
**REGION:** IL, MT  
**TYPE:** Alcohol Drag Racing

### PRO ALL STARS SERIES (PASS)

195 Lakehouse Rd.  
Naples, ME 04055  
207-693-6497  
passracing@roadrunner.com  
proallstarseries.com  
**REGION:** CT, MA, ME, NC, NH, VT  
**TYPE:** National Super Late Models,  
North Super Late Models, New England  
Supermodified Series, and PASS Modifieds

### PROFESSIONAL DRAG RACERS ASSOCIATION (PDRA)

731-345-9058  
tyler@pdra660.com  
pdra660.com  
**REGION:** MD, MI, NC, OH, SC, TN, VA  
**TYPE:** Drag Racing

# EXTREME BLACK™

## Severe Application Valves

- High Nickel Stainless Alloy 1pc. Forgings
- Special Black Nitride Process (not a coating)
- Designed for High Horsepower Applications
- Runs Cooler, Improves Valve Life
- Fully CNC Machined Finished
- Surface Finish is Smoother than Chrome
- Higher Micro-Hardness than Stainless
- Undercut Stems for Increased Flow
- Great for Naturally Aspirated Applications
- Great for Nitrous Applications
- Great for Turbo Applications
- Great for Supercharged Applications

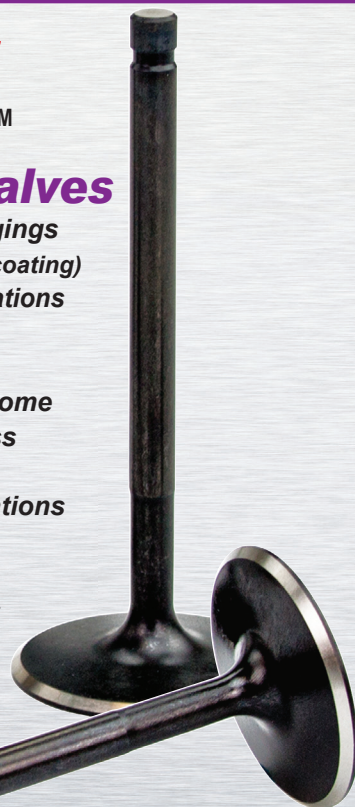

920-233-5228

www.HowardsCams.com



## EXCLUSIVE ENGINE BEARING SUPPLIER OF ROUSH YATES ENGINES

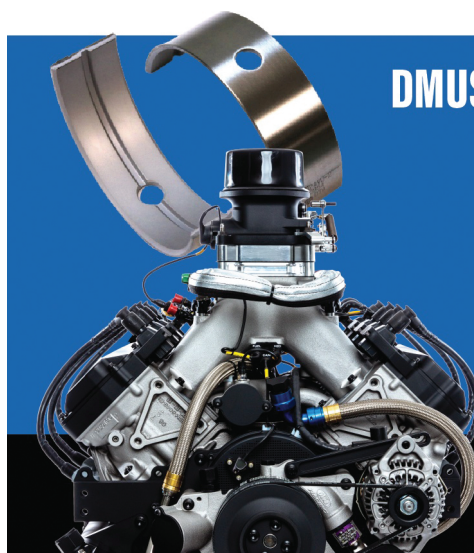

DMUSA-ORDERS@DAIDOMETAL.COM

DAIDO METAL USA, INC.  
EST. 1939

BELLEFONTAINE, OHIO  
FARMINGTON HILLS, MICHIGAN

WHERE PERFORMANCE  
MEETS PROTECTION



Booth 2101  
PRI 2024



Development · Race · Production · Restoration



**3 LOCATIONS  
SAME GREAT SERVICE!**

**LINE2LINE (HQ)**

4866 White Lake Rd.  
Clarkston, MI 48346  
(248) 625-3052

**LINE2LINE SOUTHEAST**

580 Prison Camp Rd.  
Campbello, SC 29322  
(864) 473-0637

**LINE2LINE WEST**

1406 #4 Industrial Way  
Gardnerville, NV 89410  
(775) 782-4060

Improve new parts



Restore used parts

WWW.LINE2LINECOATINGS.COM

### PROTOTYPE SPRINT SERIES ASSOCIATION (PSSA)

5487 E. Lake Rd.  
Romulus, NY 14541  
888-965-7872  
kathy@prototypesprint.com  
prototypesprint.com  
**REGION:** CA, CT, GA, NV, NY, OR, TX, VA, WI  
**TYPE:** Prototype Race Cars in a Sprint Format

### QUARTER MIDGETS OF AMERICA (QMA)

31444 54th Ave. S.  
Auburn, WA 98001  
206-683-4041  
president@quartermidgets.org  
quartermidgets.org  
**REGION:** USA and Canada  
**TYPE:** Midget Racing

### RACE OF CHAMPIONS

174 E. Main St., PO Box 161  
East Aurora, NY 14052  
info@rocmmodifiedseries.com  
rocmmodifiedseries.com  
**REGION:** Northeast  
**TYPE:** Pavement Modifieds

### RACESAVER SPRINT SERIES

18561 Chicago Ct., Apt. 202  
Elkhorn, NE 68022  
402-238-2595  
racesaver@yahoo.com  
racesaver.com  
**REGION:** USA  
**TYPE:** Sprint Cars

### RUSH RACING SERIES

4368 US 422  
Pulaski, PA 16143  
724-964-9300  
info@rushracingseries.com  
rushracingseries.com  
**REGION:** DE, MD, NY, PA, VA, WV  
**TYPE:** Dirt Late Models, Sprint Cars, Stock Cars, Modifieds, and Karts

### SCORE INTERNATIONAL

9434 Bond Ave.  
El Cajon, CA 92021  
775-852-8907  
registration@score-international.com  
score-international.com  
**REGION:** USA and Mexico  
**TYPE:** Off-Road Racing, Desert Racing

### SMART MODIFIED TOUR

smartmodtour.com  
**REGION:** NC, SC, VA  
**TYPE:** Asphalt Modified Racing

### SOUTHERN ALL STAR DIRT RACING SERIES

132 Jetplex Ln.  
Madison, AL 35758  
256-655-7260  
matt.wagner@sasdir.com  
sasdir.com  
**REGION:** USA  
**TYPE:** Dirt Late Model

### SOUTHERN CALIFORNIA TIMING ASSOCIATION & BONNEVILLE NATIONALS

PO Box 10  
Orosi, CA 93647  
559-528-6279  
office@scta-bni.org  
scta-bni.org  
**REGION:** CA, UT  
**TYPE:** Land Speed Racing

### SOUTHERN NEVADA OFF ROAD ENTHUSIASTS (SNORE)

4780 W. Ann Rd., Ste. 5452  
North Las Vegas, NV 89031  
702-736-6355  
info@snoreracing.net  
snoreracing.net  
**REGION:** NV  
**TYPE:** Off Road

### SOUTHERN THUNDER SUPER DIRT SERIES

6 Birch St.  
Woodruff, SC 29388  
864-871-1442  
southernthundersds@gmail.com  
southernthundersseries.com  
**REGION:** AL, GA, MS, TN  
**TYPE:** Super Dirt Late Model Racing

### SOVREN

17806 Bass LN. NW  
Lakebay, WA 98349  
425-205-8937  
sovrenracing.org  
**REGION:** Pacific Northwest  
**TYPE:** Vintage Racing

## SPEARS (SRL) SOUTHWEST TOUR SERIES

PO Box 6217  
Bakersfield, CA 93386  
661-679-4681  
lcollins@mesamarin.com  
srlsouthwesttour.com

**REGION:** Southwest  
**TYPE:** Pavement Late Model Racing,  
Pavement Modified Racing

## SPEED ENERGY STADIUM SUPER TRUCKS

7100 Weddington Rd.  
Concord, NC 28027  
704-949-1255  
info@stadiumsupertrucks.com  
stadiumsupertrucks.com

**REGION:** USA and Australia  
**TYPE:** Off-road Truck Racing

## SPORT COMPACT DIRT RACING ASSOCIATION

6 Birch St.  
Woodruff, SC 29388  
864-871-1442  
kelcarms@gmail.com  
scdra.net  
**REGION:** USA  
**TYPE:** Sport Compact Dirt Racing

## SPORTS CAR CHAMPIONSHIP CANADA (SCCC)

23 Hannover Dr., Ste. 2  
St. Catharines, ON L2W 1A3  
Canada  
905-704-8585  
info@felmotorsports.com  
felmotorsports.com  
**REGION:** Canada  
**TYPE:** Road Racing

## SPORTS CAR CLUB OF AMERICA (SCCA)

6620 SE Dwight St.  
Topeka, KS 66619  
800-770-2055  
membership@scca.com  
scca.com  
**REGION:** USA  
**TYPE:** Road Racing, Auto Cross

# ROSS

racing pistons



## PERFORMANCE PISTONS

IT'S WHAT WE DO.

WWW.ROSSPISTONS.COM | (310) 536-0100 | SALES@ROSSPISTONS.COM

## PYROTECT SAFETY GEAR, FUEL CELLS AND ACCESSORIES FOR 2024.

**PYROTECT**  
www.pyroprotect.com



**PROCELL ELITE** Standard Fuel Cells & Bladders from 5 to 60 Gallon. FIA-FT3 Approved.

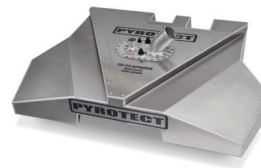

**CUSTOM FUEL CELLS** Specializing in Custom Fuel Cells any size or shape. FIA-FT3 & FT3.5 Approved.



**PRO SPORT SA2020 TFA HELMET** Available in White, Flat Black, Gloss Black, & Carbon



**PRO SPORT SA2020 SFA HELMET** Available in White, Flat Black, Gloss Black, and Carbon



**FIA CAMLOCK HARNESS** with Lt. Weight Adjusters. Available in 6 Point, Black, Red, Blue and Silver.



**PRO-ONE FIA RACE SUIT** 3 Layer Nomex Approved to FIA 8856-2000



**SINGLE & DUAL MOUNT PLATES** Available for Aeromotive or Weldon High Performance Pumps.



**FIA ANKLE TOP RACING SHOES** Available in Red, Black, and White.

©PYROTECT 2024 All Rights Reserved.

Now Order online at [www.pyroprotectstore.com](http://www.pyroprotectstore.com) or call us toll free at 800-669-2355

FUEL CELLS • HELMETS • FIRESUITS • SEAT BELTS • GLOVES • SHOES

# CalTracs WORKS.

Hooking  
consistently and  
winning races...

Patented CalTracs  
maintains pinion angle and  
prevents the axle wrap that  
damages leafspring suspensions.

Low Pro and Drag Profile,  
Truck and Monster  
kits available

2024 AT FULL THROTTLE

**CALVERT  
RACING**

CalvertRacing.com

ASK A TECH:

661-728-9600

Hours: M-F 8am-4:30pm PST



MADE IN THE USA

2024

**MASTA**  
**PERFORMANCE** INC.

Racing Transmission Accessories  
Hi-Performance Applications

Home of the Original  
"TRICK STICK"



**Fill Tube Assemblies**  
for automatic transmissions  
Over 40 models in stock

**Custom Applications**  
made to your specs

**Engine Oil Dipstick Assemblies**  
now available for most applications  
[www.mastaperformance.com](http://www.mastaperformance.com)

**BOOTH # 332**

(248) 685-8710 • FAX (248) 685-3710

## SECTION 6

## RACE SANCTIONING ORGANIZATIONS

### SPORTSCAR VINTAGE RACING ASSOCIATION (SVRA)

5487 E. Lake Rd.  
Romulus, NY 14541  
888-965-7872  
kathy@svra.com  
svra.com

**REGION:** USA

**TYPE:** Vintage Sports Car Racing

### SRO MOTORSPORTS GROUP AMERICA

PO Box 633  
Arlington, NE 68002  
531-444-8558  
sro-motorsports.com

**REGION:** USA

**TYPE:** Road Racing: Fanatec GT World  
Challenge America, TC America, GR Cup  
North America, Pirelli GT4 America

### STARS CHAMPIONSHIP SERIES

PO Box 2166  
Noblesville, IN 46061  
317-774-7021  
info@starschampionshipseries.com  
starschampionshipseries.com

**REGION:** IN, NC, OH, PA

**TYPE:** Karting

### SUMMIT RACING MIDWEST DRAGS

PO Box 155  
Westfield, IN 46074  
317-299-7223  
heid@midwestdrags.com  
summitmidwestdrags.com

**REGION:** MD, NJ, VA

**TYPE:** Drag-N-Drive

### SUPER DIRT CAR SERIES

7575-D Westwinds Blvd.  
Concord, NC 28027  
704-795-7223  
info@dirtycar.com  
superdirtcarseries.com

**REGION:** USA and Canada

**TYPE:** Big Block Modified Racing

### SUPERKARTS! USA (SKUSA)

33175 Temecula Pkwy., Ste. 233  
Temecula, CA 92592  
951-491-0808  
info@superkartsusa.com  
superkartsusa.com

**REGION:** USA and Canada

**TYPE:** Shifter Kart Racing

### TEXAS DIRT TRUCK SERIES

210-449-4506  
texasdirtruckseries@gmail.com  
texasdirtrucks.com

**REGION:** TX

**TYPE:** Dirt Truck Racing

### TOP GUN SPRINT SERIES

11108 Riverview Dr.  
Riverview, FL 33578  
813-503-8134  
annrehm43@gmail.com  
topgunsprints.com

**REGION:** FL

**TYPE:** Winged Dirt Sprint Car Racing

### ULTRA4 RACING

844-590-1234  
info@ultra4usa.com  
ultra4usa.com

**REGION:** USA, Mexico, Europe

**TYPE:** Off Road and King of the Hammers

### UNITED MANUAL TRANSMISSION RACERS NORTH

216-402-8901  
umtr.north1@gmail.com  
umtrnorth.com

**REGION:** OH

**TYPE:** Stick-shift Drag Racing

### UNITED MANUAL TRANSMISSION RACERS SOUTH

1339 St. Rt. 50  
Milford, OH 45150  
513-748-4586  
umtrsouth@gmail.com  
umtrdragrace.com

**REGION:** IN, KY, OH,

**TYPE:** Stick-shift Drag Racing

### UNITED REBEL SPRINT SERIES

822 Longhorn Ave.  
Jetmore, KS 67854  
620-393-5450  
racedcrp@gmail.com  
urssracing.com

**REGION:** KS, MO, NE, OK

**TYPE:** 305 Sprint Car Series



### UNITED SPRINT CAR SERIES

175 Antebellum Way  
Fayetteville, GA  
770-865-6097  
peteuscs@att.net  
uscsracing.com  
**REGION:** USA  
**TYPE:** Sprint Car Racing

### UNITED STATES ASSOCIATION OF PULLERS

731-445-2492  
cynthia@usapullers.org  
usapullers.org  
**REGION:** KY, MO, TN  
**TYPE:** Pulling

### UNITED STATES AUTO CLUB (USAC)

4910 W. 16th St.  
Speedway, IN 46224  
317-247-5151  
richie@usacracing.com  
usacracing.com  
**REGION:** USA  
**TYPE:** Silver Crown, Sprint Car, Midget, Ignite, 25 Next Gen, Off-Road, Rally

### UNITED STATES MODIFIED TOURING SERIES

PO Box 905  
Webster City, IA 50595-0905  
515-832-7944  
media@usmts.com  
usmts.com  
**REGION:** USA  
**TYPE:** Dirt Modified

### UNITED STATES RACING ASSOCIATION

PO Box 905  
Webster City, IA 50595-0905  
515-832-6000  
media@usraracing.com  
usraracing.com  
**REGION:** USA  
**TYPE:** Modified Stock Cars, Late Model, Sprint Cars, B-Mods, Hobby

### UNITED STATES SPEED ASSOCIATION

750 E. 900 S.  
Pendleton, IN 46064  
317-938-5726  
info@ussaracing.com  
ussaracing.com  
**REGION:** IN, MI, OH  
**TYPE:** Kenyon Midget Races

# PROFORM

RACE SERIES

## PROFORM® RACE SERIES VEHICLE SCALES WORTH THEIR WEIGHT

**14,000 lb. High-Capacity  
Wireless System**  
**Part Number: 67641**  
**Capacity per Pad: 3,500 lbs.**  
**Resolution: 1/2 of 1%**  
**Pad Dimensions: 16" x 16" x 1 3/4"**



### LEARN MORE AT

[WWW.PROFORMPARTS.COM/VEHICLE-SCALES](http://WWW.PROFORMPARTS.COM/VEHICLE-SCALES)

## Every Toolbox Needs...

### WALTON™ Tap Extractors & Tap Extensions

Performance professionals have depended on high-quality Walton tools since 1908.

#### TAP EXTRACTORS

- Remove broken taps simply and safely, without drilling, lasers, damaged threads, scrapped parts or repair inserts.
- Available in every tap size, both inch and metric.

#### TAP EXTENSIONS

- Extend the reach of regular-length taps and allow tapping in deep holes and awkward locations.
- Square and round sockets conform to leading tap sizes.
- Suitable for both machine and hand-tapping.



*Tapping into good ideas  
for over 110 years.*

(860) 523-5231  
sales@waltontools.com

[www.WaltonTools.com](http://www.WaltonTools.com)



*Available as sets or  
individual pieces.*

# SECTION 6

## RACE SANCTIONING ORGANIZATIONS

### Tie Down brackets



*If you have CalTracs, you have Tie Down Points*

**EASY TO INSTALL/EASY TO ACCESS**  
Designed to bolt onto your CalTracs Mounts. Two styles available:  
45° angle, 90° angle  
1/4" Zinc-Plated Steel to resist rust Overall size: 5-1/8" x 4". Hook/Strap Hole 1-3/8"  
NOTE: Dos not include straps.

2024 AT FULL THROTTLE  
**CALVERT RACING**

**CalvertRacing.com**  
ASK A TECH:  
**661-728-9600**  
Hours: M-F 8am-4:30pm PST



MADE IN THE USA



**FORGED PISTONS**

**MADE WITH PRIDE IN THE USA**

**PERFORMANCE-FORGE.COM**  
**323.722.3460**

### UNITED STATES TOURING CAR CHAMPIONSHIP (USTCC)

PO Box 2008  
Napa, CA 94558  
707-643-1000  
ali@ustcc.com  
ustcc.com  
**REGION:** USA  
**TYPE:** Road Racing

### UNLIMITED OFF-ROAD RACING (UNLTD)

29755 Kirsten Ln.  
Vista, CA 92084  
760-802-8503  
info@unlimitedoffroadracing.com  
unlimitedoffroadracing.com  
**REGION:** AZ, CA, NV  
**TYPE:** Off-road Racing

### UPPER MIDWEST RENEGADES SPRINT CAR SERIES

612-363-5302  
ron@umsprints.com  
umsprints.com  
**REGION:** MN, WI  
**TYPE:** Sprint Car Racing

### US LEGEND CARS INTERNATIONAL

5245 State Highway 49  
Harrisburg, NC 28075-8476  
704-455-3910  
gechapman@uslegendcars.com  
uslegendcars.com  
**REGION:** USA  
**TYPE:** Legends, Bandoleros

### USF2000 PRESENTED BY CONTINENTAL TIRE

10101 US Highway 41 N.  
Palmetto, FL 34221  
941-845-2500  
info@usfproracing.com  
usf2000.com  
**REGION:** USA and Canada  
**TYPE:** Open Wheel Racing Series

### VINTAGE AUTO RACING ASSOCIATION (VARA)

4195 Chino Hills Pkwy., #457  
Chino Hills, CA 91709  
800-280-8272  
vara@msn.com, vararacing.com  
**REGION:** CA  
**TYPE:** Pre-war Historics, All Vintage Race Cars Up to 1989

### WHELEN MAZDA MX-5 CUP PRESENTED BY MICHELIN

10101 US Highway 41 N.  
Palmetto, FL 34221  
941-845-2500  
info@mx-5cup.com  
mx-5cup.com  
**REGION:** USA  
**TYPE:** Road Racing

### WISSOTA PROMOTERS ASSOCIATION

2700 1st St. N., Ste. 209  
Saint Cloud, MN 56303  
320-251-1360  
rod@wissota.org  
wissota.org  
**REGION:** USA and Canada  
**TYPE:** Late Model, Modified, Super Stock, Midwest Mod, Street Stock, Pure Stocks, Hornets, Mod Four

### WORLD DRAG RACING ALLIANCE (WDRA)

PO Box 701  
Norwalk, OH 44857  
567-224-0568  
info@racewdra.com  
racewdra.com  
**REGION:** USA and Canada  
**TYPE:** Sportsman Drag Racing

### WORLD EXTREME ROCK CRAWLING

51 N. Broadway, #142  
Blackfoot, ID 83221  
530-417-5333  
bigrich@werocklive.com  
werocklive.com  
**REGION:** USA  
**TYPE:** Off-road, Event Promoter

### WORLD KARTING ASSOCIATION

560 Pitts School Rd. NW, Ut. G  
Concord, NC 28027  
704-455-1606  
info@worldkarting.com  
worldkarting.com  
**REGION:** USA  
**TYPE:** Kart Racing

### WORLD RACING GROUP

7575-D Westwinds Blvd.  
Concord, NC 28027  
704-795-7223  
info@dirtcar.com

worldracinggroup.com

**REGION:** USA

**TYPE:** DIRTcar Racing, World of Outlaws,  
Xtreme Outlaw Series

### WORLD RACING LEAGUE

4150 Jersey Pike  
Chattanooga, TN 37421  
423-321-2111

race@racewrl.com

racewrl.com

**REGION:** USA

**TYPE:** Road Racing

### WSK PROMOTION SRL

Piazza della Repubblica, 8  
73024 Maglie (Le)

Italy

+39-03896830753

info@wskarting.com

wskarting.it

**REGION:** International

**TYPE:** Kart Racing



LIGHTWEIGHT, AMERICAN MADE STEERING COLUMNS AND ACCESSORIES



Pro-Lite  
Steering Column



Pro-Fab  
Steering Column



Push To Connect  
Quick Release Steering Hub



DESIGNED BY RACE MINDED PEOPLE TO SAVE WEIGHT  
WITH A SAFETY FIRST MINDSET

Scan for More Info

IDIDIT LLC., 610 S. Maumee Street, Tecumseh, MI | 517-424-0577 | ididit.com



**BOOTH #317**

**949.567.9000**  
**WWW.CP-CARRILLO.COM**



**CARRILLO**  
**ALUMINUM RODS**  
POWER & PERFORMANCE  
REDEFINED.

Engineered for unmatched strength,  
precision forging, advanced fasteners,  
superior material, & innovative design.

Trusted by top teams in various  
classes of racing, providing the  
competitive edge needed to win.

# CHAMP PANS

QUALITY RACING PRODUCTS by JR Mfg.



We offer over 1,000  
high performance products used in  
Racing, Street, Off-Road and Marine for  
Chevrolet, Chrysler and Ford applications.

**715-834-7748**

Visit Our Website  
[www.champpans.com](http://www.champpans.com)

Email Us:  
[jrmfg@champpans.com](mailto:jrmfg@champpans.com)



SECTION

7

# MANUFACTURERS' REPRESENTATIVES

Manufacturers' representatives serve as an invaluable link between vendors and racing operations that sell their components. These industry sources can quickly prove their worth as they track industry trends, are aware of new products entering the market, and can be an inside source to the suppliers they represent. These reps often have years of market experience to guide smaller racing operations to better their buying decisions.

**10K SALES & MARKETING**

Dave Sutton  
623 Nightingale Blvd., Stillwater, MN 55082  
651-238-5788  
hrdprts@earthlink.net  
**TERRITORY:** MN, ND, SD, WI

**AIRHEART SALES**

Jim Link  
13805 409th Ave. SE  
North Bend, WA 98045  
425-888-2540, seattlerep@aol.com  
airheartsales.com  
**TERRITORY:** AZ, CA, CO, ID, MT, NM, NV, OR, TX, UT, WA, & Western Canada

**ALL-MIDWEST SALES**

Jim Morehouse  
2111 Lanterman Circle  
Hinckley, OH 44233  
216-225-4564, allmidwestsales.com  
**TERRITORY:** AL, AR, CO, FL, GA, IA, IL, IN, KS, KY, LA, MI, MN, MO, MS, NC, ND, OH, OK, SC, SD, TN, TX, VA, WI, WV

**AMERICAN SALES & MARKETING**

825 College Blvd., Ste. 102-315  
Oceanside, CA 92057  
760-726-8226, info@asmwp.com  
asmwp.com  
**TERRITORY:** USA

**APPLIED COMPONENTS**

33410 Liberty Pkwy.  
North Ridgeville, OH 44039  
440-458-4638  
jevangelista@aci-sales.com, aci-sales.com  
**TERRITORY:** CT, DE, FL, GA, IA, IL, IN, KY, LA, MD, ME, MI, MN, MS, NC, NH, NJ, NY, OH, PA, RI, SC, TN, VA, VT, WI, WV, & ON, Canada

**AUTOREP SALES COMPANY**

725 S. Adams Rd., Ste. L-145  
Birmingham, MI 48009  
844-361-4345  
info@autorepsales.com, autorepsales.com  
**TERRITORY:** IL, IN, KY, MI, OH, Western PA, WI, WV

**BALLARD & ALLEN MARKETING**

711 W. 17th St., Ste. F7,  
Costa Mesa, CA 92627  
949-722-7716  
sales@ballardallen.com  
ballardallen.com  
**TERRITORY:** Western 11 states & Western Canada

**BC SALES & MARKETING**

5588 Jacksontown Rd.  
Newark, OH 43056  
330-730-0302  
**TERRITORY:** IN, KY, MI, OH

**BOB COOK SALES**

9245 Poplar Ave., Ste. 5 #129  
Germantown, TN 38138  
901-854-4632  
bobcooksales.com  
**TERRITORY:** AL, AR, CO, FL, GA, IN, KY, LA, MS, NC, NM, OK, PA, SC, TN, TX, VA, WV

**KEEP UP WITH PRI**

PRISHOW.COM/SOCIAL

**PRI**  
PERFORMANCE RACING INDUSTRY

**M2 BRANDWEAR**  
DESIGN • SCREENPRINT • SEW • PROMOS

**THE SOURCE FOR Custom DESIGN AND APPAREL**

www.m2brandwear.com  
**FOR FREE ESTIMATE: mike@m2sales.net**

## SECTION 7

## MANUFACTURERS' REPRESENTATIVES



**COMETIC**  
GASKET

ph: (440) 354-0777 · 1 (800) 752-9850

www.cometic.com

f t i in

440-205-1055



**Advanced**  
S L E E V E

WWW.ADVANCEDSLEEVE.COM



**CECOMP® F20B Series**  
Ruggedized 8 Memory Pressure Gauges

CECOMP®  
PS:6

±0.25%  
or ±0.1%  
Accuracy

Made in USA

Tires - Shocks - Compression - Vacuum

cecomp.com 800-942-0315



**STIFFLERS**

Innovative Products  
for the  
**WINNER'S  
CIRCLE!**

FIND US AT BOOTH #1511

f i y www.BUYSTIFFLERS.COM

**CHRIS KOURI & ASSOCIATES**

Chris Kouri  
1200 N. Jefferson St., Ut. K  
Anaheim, CA 92807  
714-630-2311  
chriskouri.com  
**TERRITORY:** AK, AZ, CA, HI, ID, NV, OR, WA

**CONSIDINE SALES & MARKETING**

Jim Considine III  
611 S. Milford Rd.  
Highland, MI 48357  
248-889-7887  
considinesales.com  
**TERRITORY:** IA, IL, IN, KS, KY, MI, MO, MN, ND, NE, OH, Western PA, SD, WI, WV

**DEVEREAUX JONES COMPANY**

Devereaux Jones  
1355 Canadaville Loop  
Eads, TN 38028  
901-317-6937  
devjones@djonesco.com  
**TERRITORY:** USA

**FOSTER BABCOCK & ASSOCIATES**

Brenda Babcock  
313 Delaware St.  
Kansas City, MO 64105  
816-283-3355  
fba@fosterbabcock.com  
fosterbabcock.com  
**TERRITORY:** USA

**HARRY MILLER SALES**

Harry Miller  
162 Doug Allison Heights  
Cleveland, GA 30528  
706-809-9145  
hmiller@harrymillersales.com  
harrymillersales.com  
**TERRITORY:** USA & Canada

**JAMISON EQUIPMENT**

1908 11th St.  
Emmetsburg, IA 50536  
800-841-5405  
info@jamisonequipment.com  
jamisonequipment.com  
**TERRITORY:** IA, MN, ND, NE, SD

**JIM KERR & ASSOCIATES**

45 Carriage House Dr.  
Holland, PA 18966-2224  
215-355-3613  
jimkerr@jimkerr.com  
jimkerr.com  
**TERRITORY:** DE, MD, NJ, NY, PA, VA (Fairfax County)

**JIM WROBLESKI & CO.**

Jim Wrobleski Jr.  
2146 N. Karwick Rd., Ste. A  
Michigan City, IN 46360-7381  
219-879-8145  
jwcreps.com  
**TERRITORY:** IL, IN, KY, MI, MN, ND, OH, PA, SD, WI, WV

**KAM MARKETING**

Bernie Meyer  
411 Old Baltimore Pike, Ste. 101  
Chadds Ford, PA 19317  
302-658-7778  
sales@kammarketing.com  
kammarketing.com  
**TERRITORY:** USA & Eastern Canada

**KUNZMAN & ASSOCIATES**

4094 Pioneer Dr.  
Walled Lake, MI 48390-1351  
248-360-2700  
kunzman.com  
**TERRITORY:** AK, AL, AR, AZ, CA, CO, CT, DE, FL, GA, HI, IA, ID, IL, IN, KS, KY, LA, MO, MT, NE, NC, ND, NH, NJ, NM, NV, NY, OH, OK, OR, PA, RI, SC, SD, TN, TX, UT, VA, VT, WA, WI, WV, WY, and AL, BC, SK, Canada

**MACK EQUIPMENT SALES**

Jim Backus  
4224 Lassek Ct.  
Eau Claire, WI 54703  
715-579-8423  
mackequipmentsales.com  
**TERRITORY:** IA, IL, Upper Peninsula of MI, MN, NE, ND, SD, WI

**MC SALES & MARKETING**

15581 Computer Ln.  
Huntington Beach, CA 92649  
714-901-8589  
sales@mcsalesmarketing.com  
mcsalesmarketing.com  
**TERRITORY:** AK, AZ, CA, CO, HI, ID, MT, NM, NV, OR, UT, WA, WY, and BN, BS, CI, CH, Mexico

**OWEN EQUIPMENT SALES**

84 Andrea Dr.  
Richboro, PA 18954-1302  
owenequipment1@comcast.net  
**TERRITORY:** DE, MD, NJ, PA

**PROREP MARKETING**

Adam Olson  
14 Meade Ln.  
Enfield, CT 06082  
860-698-6022  
aolson@prorepmarketing.com  
prorepmarketing.com  
**TERRITORY:** DC, DE, MD, NJ, NY, PA, New England, and Eastern Canada

**R & R MARKETING CONSULTANTS**

PO Box 481383, Kansas City, MO 64148  
650-588-3404, rr@rrmci.com  
rrmci.com  
**TERRITORY:** North America

**REPFORCE**

210 Turner Industrial Way  
Aston, PA 19014  
610-485-7800, sales@repforce.com  
repforce.com  
**TERRITORY:** AL, CO, DE, FL, GA, IA, IL, IN, KY, MD, MI, MN, MT, NC, ND, NE, NJ, NY, OH, PA, PR, SC, SD, TN, UT, VA, WI, WV, WY, and Eastern Canada

**REPWORKS MARKETING**

John Belzner  
3707 E. Southern Ave.  
Mesa, AZ 85206  
602-279-1988  
jb@repworksmktg.com  
repworksmktg.com  
**TERRITORY:** AK, AZ, CA, HI, NM, NV, OR, WA

**RT SALES**

1625 N. Milford Rd.  
Highland, MI 48357-3807  
248-887-0422  
rtsales@rtsalesinc.com  
rtsalesinc.com  
**TERRITORY:** USA

**SCOTT LEWIS ASSOCIATES**

994 Northern Blvd.  
Baldwin, NY 11510  
516-378-6100  
scottlewisinc.com  
**TERRITORY:** USA and Eastern Canada, Western Canada

**SHERMAN PEARSON COMPANY**

26309 Miles Rd., Ste. 5  
Cleveland, OH 44128-5997  
216-464-3094  
shermanpearson.com  
**TERRITORY:** IL, IN, KY, MI, NY, OH, West PA, WI, WV

**THOMAS SALES AND MARKETING**

317-846-7024  
ron.thomasco@sbcglobal.net  
thomassalesco.com  
**TERRITORY:** IL, IN, KY, MI, OH, PA, WI, and WV

**UHLE & CLARK**

1452 Turkey Trot Rd.  
Warwick, PA 18974  
215-588-0067  
uhleclark.com  
**TERRITORY:** DC, DE, MD, NJ, Metro NY, Eastern PA, and VA

**WOODWARD EQUIPMENT**

15790 SE Piazza Ave., Ste. 104  
Clackamas, OR 97015-9141  
503-657-6680  
info@woodwardequipment.com  
woodwardequipment.com  
**TERRITORY:** USA

## Gen III Hemi Swap, Pan Kit



- Saves space over cast oil pans
  - 1" shorter at only 6" deep
  - Saves ½" depth in the front over a cross member
  - Sump length of 9 ½" allows tons of room to any steering
- Complete kit includes:
  - oil pan, pickup, windage tray, pan gasket and pan bolts
- If your engine has a stroker crank, aftermarket heads or even a turbo, don't just get "a" pan. Get one that will allow your engine and chassis to perform at 100% and is really up to the level of your build!

Gen III 5.7-6.1-6.4, Mid-Sump, 2009 & up kit: .....	<b>#31000-1</b>
Gen III 5.7-6.1-6.4, Mid-Sump, 2003-2008 kit: .....	<b>#31000-2</b>
Gen III 5.7-6.1-6.4, Rear-Sump, 2009 & up kit: .....	<b>#31006-1</b>
Gen III 5.7-6.1-6.4, Rear-Sump, 2003-2008 kit: .....	<b>#31006-2</b>
Hellcat 6.2, Rear-Sump kit: .....	<b>#31007-1</b>



**MADE IN USA**



Visit Milodon on the web for additional information:  
**www.milodon.com**  
Simi Valley, CA • (805) 577-5950

SECTION

8

# WAREHOUSE DISTRIBUTORS

Carrying a vast product inventory with responsive shipping options may be the hallmark of warehouse distributors, but the partnerships that form as a result reveal their true value. WDs serve as a link between parts manufacturers and independent motorsports business operations. However, they offer much more than solely serving as a parts warehouse as a number of these provide multiple locations, same-day shipping, online inventory tracking, plentiful customer service reps, and much more to help your racing business succeed.



**AFTERMARKET  
PERFORMANCE GROUP**

7976 Rubicon Trail Pl. NW  
Silverdale, WA 98383  
888-497-3666  
aftermarketperformancegroup.com

**ALLPRO DISTRIBUTING**

43 Airpark  
Alabaster, AL 35007  
800-858-4487  
customercare@allprodistributing.net  
allprodistributing.net

**ATECH MOTORSPORTS**

1200 Southeast Ave.  
Tallmadge, OH 44278  
800-517-1040  
customerservice@atechmotorsports.com  
atechmotorsports.com

**BEHRENT'S PERFORMANCE  
WAREHOUSE**

38 Meadow Rd.  
Florida, NY 10921  
845-651-7389  
behrents.com

**BOLTSANDNUTS.COM**

3705 Lane Rd. Ext.  
Perry, OH 44081  
440-606-6557  
info@boltsandnuts.com  
boltsandnuts.com

**COMPETITION PRODUCTS**

280 W. 35th Ave.  
Oshkosh, WI 54902  
800-233-0199  
info@competitionproducts.com  
competitionproducts.com



**Head Studs / Main Studs / Rod Bolts / Custom**

PRI Booth #1533  
P1mfg.com

info@P1mfg.com  
417-753-5174

**PENSKE**  
RACING SHOCKS

**3 SHOCK  
SETUP  
SUPPORT**

DESIGNED TO WIN

f @penskeshocks  
i @penske\_racing\_shocks  
y @penseracingshocks

WWW.PENSKESHOCKS.COM  
610-375-6180 BOOTH #425

**ROBINS**  SINCE 1983  
*Signature brand* -1+ Exactly

**RUBI BORE**  
**1.5 Smart**  
Cylinder Boring Machines

**RUBI PLATO BORING**  
BORING CAPACITY  
**2.200"-4.100"**  
(56-105 mm)

f @ /robinsmachines rc@RobinsMachines.com  
www.RobinsMachines.com

**CONNECT**



PRISHOW.COM/SOCIAL

**PRI**

CONGRATS #TEAMISKY  
**MURDER**  
NOV  
NO PREP ELITE SEASON 7 CHAMPION

**ISKY RACING CAMS**

Facebook Instagram YouTube @ISKYRACINGCAMS ISKYCAM.COM | (310) 217-9232

• RPM: 2500-7500  
• EFI and NOS Bosses  
• Street or Strip  
• Made In America

**HARDCORE PERFORMANCE**

Developed on the Dyno and proven on the track. BMP Intake Manifolds on average show gains of 10+ HP over the competition.

4500 Carb Flange

Check Out Our Huge Selection Of High Performance Parts at  
**BILLMITCHELLPRODUCTS.COM**  
**386.957.3009**

**SBC BBC SBF**

4150 Carb Flange

**BMP** HARD CORE RACING  
BILL MITCHELL PRODUCTS

**PATENTED CERAMIC LUBRICANT**

**TESTED #1 FOR EXTREME PRESSURE & FILM STRENGTH**

**TriboDyn® Lubricants**

**ENGINEERED TO:**

- ✓ Reduce Operating Temperature
- ✓ Increase Engine Life & Reduces Wear
- ✓ Perform Under Extreme Pressure & Heat
- ✓ Maximize Fuel Efficiency
- ✓ Increase Horsepower & Torque
- ✓ Form a Ceramic Film Under Extreme Conditions

**www.TriboDyn.com** Visit TriboDyn® at the 2024 PRI Show  
Booth # 513 | Green Hall  
704.266.3577 | info@TriboDyn.com

**MADE IN THE USA**

**TriboDyn** LUBRICANTS

**DAY MOTOR SPORTS**

6100 US Hwy. 69 N.  
Tyler, TX 75706  
800-543-6238  
daymotorsports.com

**DON GROSS WAREHOUSE**

1951 E. 48th St.  
Los Angeles, CA 90058  
888-366-4767  
dongross.com

**ENGINE AND PERFORMANCE WAREHOUSE**

955 Decatur St., Ut. D  
Denver, CO 80204  
303-572-8844  
epwi.net

**ENGINE PRO**

198 Industrial Park Rd.  
Piney Flats, TN 37686  
423-282-0211  
enginepro.com

**JEGS HIGH PERFORMANCE**

101 Jeg's Pl.  
Delaware, OH 43015  
800-345-4545  
jeps.com

**JOBBERS WAREHOUSE SUPPLY**

800 Third Ave. N.  
Minneapolis, MN 55405-1606  
800-489-4520  
612-377-4520  
info@enginepartspro.com  
enginepartspro.com

**JOHNSTON RESEARCH & PERFORMANCE**

2344 S. Sheridan Way  
Mississauga, ON L5J 2M4  
Canada  
905-822-7223  
jrponline.com





## KEYSTONE AUTOMOTIVE OPERATIONS

44 Tunkhannock Ave.  
Exeter, PA 18643  
800-521-9999  
customercare@keystone.com  
keystoneautomotive.com

## MEYER DISTRIBUTING

560 E. 25th St.  
Jasper, IN 47546  
800-MEYER-USA  
meyerdistributing.com

## MOSS MOTORS LTD.

440 Rutherford St.  
Goleta, CA 93117  
800-667-7872  
805-681-3400  
moss.sales@mossmotors.com  
mossmotors.com

## MOTOR STATE DISTRIBUTING

8300 Lane Dr.  
Watervliet, MI 49098  
800-772-2678  
269-463-4113  
info@motorstate.com  
motorstate.com

## NATIONAL PERFORMANCE WAREHOUSE

11150 NW 32nd Ave.  
Miami, FL 33167  
800-344-0368  
npwcompanies.com

## NICKELS PERFORMANCE

293 Industrial Park Rd.  
Piney Flats, TN 37686  
800-251-0331  
nickels-performance.com

# VAC MOTORSPORTS

www.VACmotorsports.com

Facebook Instagram Twitter YouTube @VACMOTORSPORTS  
+1 (215) 462-4666 sales@vacmotorsports.com

## MAHLE CALICO Main & Rod Bearings

- Friction Resistant Calico Coatings
- Eliminate OEM Bearing Failure
- B48 | B58 | S14 | S38 | M50 | M52 | M54 | N52 | N54 | N63 | S50 | S52 | S54 | S55 | S63 | S85 + More Applications



## VAC R11 SUPER DAMPER Crank Dampers

- Isolate Damaging Harmonic Vibrations
- Allow Engines to Produce More Horsepower
- B58 | S14 | M50 | M52 | M54 | N52 | N54 | S50 | S50B30 | S50B32 | S52 | S54 | S55 Applications



## VAC Billet Differential Covers

- Available for E36, E46 M3, E9x, Z4 / Supra
- Increased Oil Capacity and Cooling
- Improved Strength over Factory Cast Cover



## VAC Billet Engine Blocks

- High Strength 6061-T6 Aluminium Block
- Extreme Weight Savings over Factory Iron Block
- Can Stand 1500+ Horse Power
- S14 | S38 | M50 | M52 | S50 | S52 | S54 Applications

See More:



# BRASWELL

AMERICA'S FINEST COMPETITION CARBURETION  
CARBURETORS FOR CHAMPIONS

Dirt Track Oval Track  
Drag Race Road Course  
Off Road Marine

More Top End Power  
Broader Power-Band  
Smoother Acceleration  
**MORE THAN COMPLETE CARBURETORS**  
Premium Parts - Engine Building Programs - Rebuild Kits  
(520) 579-9177  
SALES@BRASWELL.COM  
WWW.BRASWELL.COM

## WEINLE MOTORSPORTS

Specializing in Custom-Built CNC Intake Manifolds & Racing Heads

New Pro-Filer 380x CNC ported 2.375x 1.850 95 degree valve angles flow over 465 - \$1985  
New Pro-Filer 12 Hitman Heads 480 CNC Ported - \$3495  
Brooks & Dart Programs Available!

CNC Billet Intakes - \$2500 Sheet Metal Intakes - \$1900 U-Weld II Kits - \$900

513-607-2592 or 513-353-1067  
www.weinlemotorsports.com - Cleves, OH

# CONNECT

X f i t l n y

PRISHOW.COM/SOCIAL

PRI

# EXPERIENCE YOU CAN TRUST

Molnar Technologies now offers its high-quality, affordable PWR ADR Plus™ connecting rods for extreme duty, maximum boost or NOS applications. These rods are made with the strength and durability you have come to expect from Molnar Technologies.

616-940-4640  
sales@MolnarTechnologies.com | www.MolnarTechnologies.com

**MOLNAR**  
TECHNOLOGIES LLC



## PLATINUM RACING PRODUCTS

2/11 Reliance Dr.  
Tuggerah, New South Wales  
Australia 2259  
+61 449 688 530  
platinumracingproducts.com

## SCOGGIN DICKEY PARTS CENTER

5901 Spur 327  
Lubbock, TX 79424  
800-456-0211  
sdparts.com

## SPEED AND ENGINE WAREHOUSE

2001 E. 19th St.  
Tucson, AZ 85719  
800-365-4292  
520-792-1830  
speedandengine.com

## SPEEDWAY MOTORS

340 Victory Ln.  
Lincoln, NE 68528  
855-313-9181  
speedwaymotors.com

## TURN 14 DISTRIBUTION

100 Tournament Dr.  
Horsham, PA 19044  
877-7TURN14  
267-468-0350  
turn14.com

## XTREME DIESEL PERFORMANCE

1758 State Route 34 N.  
Wall Township, NJ 07727  
888-DIESEL-4  
732-719-0955  
xtremediesel.com

**ROBINS** Signature brand SINCE 1983 Exactly

**RUBI BORE**  
1.2 Smart  
Cylinder Boring Machines

**RUBI PLATO BORING**

**BORING CAPACITY**  
1.750" - 3.350"  
(45-85 mm)

f @ v t i n /robinsmachines | rc@RobinsMachines.com www.RobinsMachines.com

**CONNECT**

X f i g t d  
PRISHOW.COM/SOCIAL

**PRI**  
PERFORMANCE RACING INDUSTRY

**Clarendon**  
Specialty Fasteners Inc.

The home of Motorsport brands:  
AEROCATCH | AEROLOC  
and a leading supplier of  
AEROSPACE FASTENERS

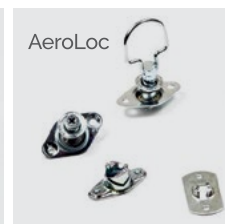
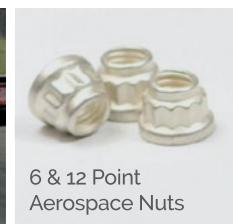

CONTACT US:  
714-842-2603  
www.clarendonsf.com  
usasales@clarendonsf.com

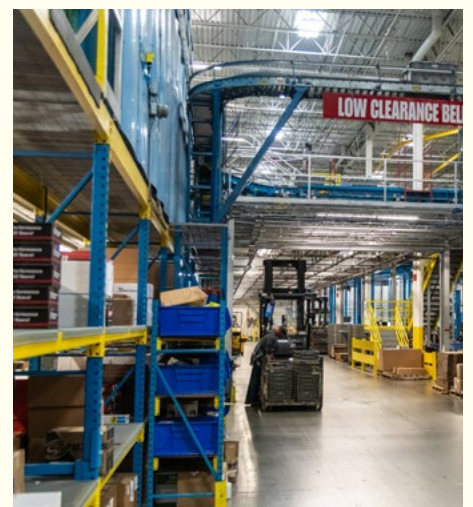



# THANK YOU

## FOR SUPPORTING ANOTHER GREAT

# *PRI*SHOW

**NOW ACCEPTING BOOTH APPLICATIONS  
FOR THE 2025 *PRI* SHOW**

DECEMBER 11-13, 2025 | INDIANAPOLIS, INDIANA

**VISIT [PRISHOW.COM](https://prishow.com)  
TO RESERVE YOUR BOOTH SPACE TODAY!**

# SUPPLIERS INDEX

## **1SPEC**

1421 Amy Ln., Ste. A  
Franklin, IN 46131  
1spec.net@gmail.com, 1spec.net  
Category: ENGINE COMPONENTS  
Entry on Page 44

## **6XD Sequential Gearbox**

707 Mooresville Rd.  
Kannapolis, NC 28081  
6xdgearbox@gmail.com  
6xdgearbox.com  
Category: CHASSIS, DRIVELINE & SUSPENSION  
Entry on Page 80

## **Advanced Clutch Technology**

206 E. Ave. K4  
Lancaster, CA 93535  
661-940-7555  
sales@advancedclutch.com  
advancedclutch.com  
Category: CHASSIS, DRIVELINE & SUSPENSION  
Entry on Page 80

## **Advantage Lifts**

33 Amy Way  
Hanover, PA 17331  
763-300-5730  
sales@advantagelifts.com  
advantagelifts.com  
Category: MACHINERY, TOOLS & EQUIPMENT  
Entry on Page 135

## **AED Metal Products**

5373 W. 86th St.  
Indianapolis, IN 46268  
317-334-0569  
sales@aedmetals.com  
aedmetals.com  
Category: CHASSIS, DRIVELINE & SUSPENSION  
Entry on Page 80

## **AERA Engine Builders Association**

875 Feinberg Ct., Ste. 106  
Cary, IL 60013  
815-526-7348  
info@aera.org, aera.org  
Category: MACHINERY, TOOLS & EQUIPMENT  
Entry on Page 135

## **Aero Exhaust**

4830 Business Center Dr., #140  
Fairfield, CA 94534  
801-301-0408  
alex.ortega@aeroexhaust.com  
aeroexhaust.com  
Category: ENGINE COMPONENTS  
Entry on Page 44

## **Altronics**

1411 S Roselle Rd.  
Schaumburg, IL 60193  
sales@altronicsinc.com  
altronicsinc.com  
Category: RACING COMPONENTS,  
ACCESSORIES & SERVICES  
Entry on Page 101

## **Anderson Composites**

1215 Bixby Dr.  
City of Industry, CA 91745  
626-333-7024  
marketing@andersoncomposites.com  
andersoncomposites.com  
Category: CHASSIS, DRIVELINE & SUSPENSION  
Entry on Page 81

## **ARP**

1863 Eastman Ave.  
Ventura CA 93003  
800-826-3045  
info@arpfasteners.com  
arp-bolts.com  
Category: ENGINE COMPONENTS  
Entry on Page 10

## **Ashcroft**

250 E. Main St.  
Stratford, CT 06614-5145  
203-378-8281  
info@ashcroft.com  
ashcroft.com  
Category: RACING COMPONENTS,  
ACCESSORIES & SERVICES  
Entry on Page 92

## **ATL Racing Fuel Cells**

45 Spear Rd.  
Ramsey, NJ 07446  
201-825-1400  
sales@atltd.com  
atltd.com  
Category: CHASSIS, DRIVELINE & SUSPENSION  
COMPONENTS  
Entry on Page 62

## **Aurora Bearing Co.**

901 Aucutt Rd.  
Montgomery, IL 60538  
630-859-2030  
jmcrrory@aurorabearing.com  
aurorabearing.com  
Category: CHASSIS, DRIVELINE & SUSPENSION  
COMPONENTS  
Entry on Page 81

## **Automatic Transmission Design**

W140N10145 Fond Du Lac Ave.  
Germantown, WI 53022  
262-251-7777  
info@autotransdesign.com  
autotransdesign.com  
Category: CHASSIS, DRIVELINE & SUSPENSION  
COMPONENTS  
Entry on Page 63

## **AutoRod Corporation**

21 Le Valley Dr.  
Englishtown, NJ 07726  
732-851-5095  
rich@autorod.net  
autorod.net  
Category: RACING COMPONENTS,  
ACCESSORIES & SERVICES  
Entry on Page 101

## **Autotech Driveline**

29 Journey  
Aliso Viejo, CA 92656  
abs@autotechdriveline.com  
race-abs.com  
Category: CHASSIS, DRIVELINE & SUSPENSION  
Entry on Page 81

## **AvioRace USA Corp.**

251 Little Falls Dr.  
Wilmington, DE 19808  
704-402-7802  
randy@avioraceusa.com  
aviorace.it/en  
Category: RACING COMPONENTS,  
ACCESSORIES & SERVICES  
Entry on Page 101

## **The BangShift Billy**

3082 Evergreen Pkwy., Ste. A  
Evergreen, CO 80439  
720-232-7189  
barmstrong@bangshiftbilly.com  
bangshiftbilly.com  
Category: RACING COMPONENTS,  
ACCESSORIES & SERVICES  
Entry on Page 102

## **Behrent's Performance Warehouse**

38 Meadow Rd.  
Florida, NY 10921  
845-651-7389  
sales@behrents.com  
behrents.com  
Category: ENGINE COMPONENTS  
Entry on Page 44

## **Billet Specialties**

500 Shawmut Ave.  
La Grange, IL 60526  
708-588-0505  
billetspecialties.com  
Category: ENGINE COMPONENTS  
Entry on Page 44

## **Blackbird Performance**

299 Albert Elliott Rd.  
Auburn, KY 42206  
blackbirdracing1@yahoo.com  
blackbird-performance.com  
Category: ENGINE COMPONENTS  
Entry on Page 44

## **BluePrint Engines**

2915 Marshall Ave.  
Kearney, NE 68847  
308-236-1010  
sales@blueprintengines.com  
blueprintengines.com  
Category: ENGINE COMPONENTS  
Entry on Page 44

## **Boker's**

3104 Snelling Ave.  
Minneapolis, MN 55406  
800-927-4377  
sales@bokers.com, bokers.com  
Category: CHASSIS, DRIVELINE & SUSPENSION  
Entry on Page 82

## **Boost Products USA**

9858 Chartwell Dr.  
Dallas, TX 75243  
469-250-9589  
orders@boostproductsusa.com  
boostproductsusa.com  
Category: ENGINE COMPONENTS  
Entry on Page 46

## **Borowski Race Engines**

1545 Mound Rd., Joliet, IL 60436  
815-725-2727  
joe@borowskirace.com  
borowskirace.com  
Category: ENGINE COMPONENTS  
Entry on Page 46

## **Bosch Motorsport**

38000 Hills Tech Dr.  
Farmington Hills, MI 48331  
brooke.bond@us.bosch.com  
bosch-motorsport.com  
Category: CHASSIS, DRIVELINE & SUSPENSION  
Entry on Page 82

## Boteler Racing Operations

PO Box 642  
Westminster, MD 21158  
410-876-6851  
botraceopr@aol.com  
botelerracing.com  
Category: RACING COMPONENTS,  
ACCESSORIES & SERVICES  
Entry on Page 102

## BR Motorsports/Ignitioneering

2216 E. Mineral King Ave.  
Visalia, CA 93292  
559-739-1515  
blake@brmotorsports.com  
brpromag.com  
Category: ENGINE COMPONENTS  
Entry on Page 12

## Braswell Carburetion

PO Box 3  
Cortaro, AZ 85652  
sam@braswell.com  
braswell.com  
Category: ENGINE COMPONENTS  
Entry on Page 46

## Bryke Racing

806 W. Pridemore Dr.  
Lincoln, AR 72744  
479-824-0966  
sales@bryke.com  
bryke.com  
Category: RACING COMPONENTS,  
ACCESSORIES & SERVICES  
Entry on Page 102

## BTR Brian Tooley Racing

2100 Filiatreau Ln.  
Bardstown, KY 40004  
888-959-8865  
sales@briantooleyracing.com  
briantooleyracing.com  
Category: ENGINE COMPONENTS  
Entry on Page 14

## Buffalo Turbine

180 Zoar Valley Rd.  
Springville, NY 14141  
btsales@buffaloturbine.com  
buffaloturbine.com  
Category: RACE TRACK EQUIPMENT &  
SUPPLIES  
Entry on Page 147

## Bully Dog Technologies

4150 Church St., Ste. 1024  
Sanford, FL 32771  
386-968-1337  
cheralyn.hale@derivesystems.com  
bullydog.com  
Category: RACING COMPONENTS,  
ACCESSORIES & SERVICES  
Entry on Page 103

## Buzze Axles

309 Performance Rd.  
Mooresville, NC 28115  
704-664-8907  
buzzeracing@gmail.com  
buzzeracing.com  
Category: CHASSIS, DRIVELINE & SUSPENSION  
COMPONENTS  
Entry on Page 82

## Calvert Racing

4530 Runway Dr.  
Lancaster, CA 93536  
661-728-9600  
sales@calvertracing.com  
calvertracing.com  
Category: CHASSIS, DRIVELINE & SUSPENSION  
COMPONENTS  
Entry on Page 64

## Cam Motion

2157 Beaumont Dr.  
Baton Rouge, LA 70806  
225-926-6110  
info@cammotion.com  
cammotion.com  
Category: ENGINE COMPONENTS  
Entry on Page 46

## Canton Racing Products

232 Branford Rd.  
Branford, CT 06471  
203-481-9460  
ianncc@cantonracingproducts.com  
cantonracingproducts.com  
Category: ENGINE COMPONENTS  
Entry on Page 46

## Capitol Renegade

11341 Old Baltimore Pike  
Beltsville, VA 20705  
301-474-6800  
wayneq@ecapitol.com  
capitolrenegade.com  
Category: RACING COMPONENTS,  
ACCESSORIES & SERVICES  
Entry on Page 103

## Cecomp Electronics

1220 American Way  
Libertyville, IL 60048  
847-918-3510  
sales@api-usa.com  
cecomp.com  
Category: CHASSIS, SUSPENSION & DRIVELINE  
COMPONENTS  
Entry on Page 83

## Centerforce Clutches

2266 Crosswind Dr.  
Prescott, AZ 86301-6183  
928-771-8422  
sales@centerforce.com  
centerforce.com  
Category: CHASSIS, DRIVELINE & SUSPENSION  
COMPONENTS  
Entry on Page 83

## Central Petroleum

PO Box 597  
Cleveland, OH 44107  
dave@cenpeco.com  
cenpeco.com  
Category: RACING COMPONENTS,  
ACCESSORIES & SERVICES  
Entry on Page 103

## Chalew Performance

208 Performance Rd.  
Mooresville, NC 28115  
704-660-1101  
parts@chalew.com  
chalew.com  
Category: CHASSIS, DRIVELINE & SUSPENSION  
COMPONENTS  
Entry on Page 83

## Champ Pans

6198 US Hwy 12  
Eau Claire, WI 54701  
715-834-7748  
jrmfg@champspans.com  
champspans.com  
Category: ENGINE COMPONENTS  
Entry on Page 46

## ClampTite Tools

PO Box 882  
Cape Canaveral, FL 32953  
800-962-2901  
clamptitertools@gmail.com  
clamptitertools.com  
Category: MACHINERY, TOOLS & EQUIPMENT  
Entry on Page 135

## Comec

7807 Addison Rd.  
Masury, OH 44438  
800-887-6076  
comecus.com  
Category: MACHINERY, TOOLS & EQUIPMENT  
Entry on Page 122

## Competition Clutch

1570 Lakeview Loop  
Anaheim, CA 92807  
714-410-1958  
info@competitionclutch.com  
competitionclutch.com  
Category: CHASSIS, DRIVELINE & SUSPENSION  
COMPONENTS  
Entry on Page 66

## Computech Systems

29971 Business Center Dr.  
Charlotte Hall, MD 20622  
301-884-5712  
sales@computech.com  
computech.com  
Category: RACING COMPONENTS,  
ACCESSORIES & SERVICES  
Entry on Page 104

## Cool Racing Parts

2119 Fowl St.  
Fort Myers, FL 33901  
239-415-2445  
sales@coolracingparts.com  
coolracingparts.com  
Category: RACING COMPONENTS,  
ACCESSORIES & SERVICES  
Entry on Page 93

## CP-Carrillo

1902 McGaw Ave.  
Irvine, CA 92614  
949-567-9000  
sales@cp-carrillo.com  
cp-carrillo.com  
Category: ENGINE COMPONENTS  
Entry on Page 16

## Crystal Clean

2000 Center Drive, Ste. East C300  
Hoffman Estates, IL 60192  
630-333-5901  
contact@crystal-clean.com  
crystal-clean.com  
Category: MACHINERY, TOOLS & EQUIPMENT  
Entry on Page 136

# SUPPLIERS INDEX

## **CTech Manufacturing**

7501 Commerce Dr.  
Weston, WI 54476  
715-355-8842  
hello@ctechmanufacturing.com  
ctechmanufacturing.com  
Category: MACHINERY, TOOLS & EQUIPMENT  
Entry on Page 123

## **D-A Lubricant Co.**

801 Edwards Dr.  
Lebanon, IN 46052  
317-923-5321  
dalube@dalube.com  
penngade1.com  
Category: RACING COMPONENTS,  
ACCESSORIES & SERVICES  
Entry on Page 104

## **Delta PAG**

1444 30th Rd.  
Astoria, NY 11102  
212-203-2912  
support@deltapag.com  
deltapag.com  
Category: ENGINE COMPONENTS  
Entry on Page 18

## **Diversified Machine Inc., DMI Racing Components/Bulldog Quick Change Rears**

430 N Franklin St.  
Lancaster, PA 17602  
717-397-5347  
davee@diversifiedracing.com  
diversifiedracing.com  
Category: CHASSIS, DRIVELINE & SUSPENSION  
COMPONENTS  
Entry on Page 84

## **Doc's Diesel**

614 E. Edgerton St.  
Bryan, OH 43506  
419-551-6138  
sales@docsdiesel.com  
docsdiesel.com  
Category: ENGINE COMPONENTS  
Entry on Page 48

## **Drift List**

105 Flessner Ave.  
Rantoul, IL 61866  
patrick@driftlist.com  
driftlist.com  
Category: CHASSIS, DRIVELINE & SUSPENSION  
COMPONENTS  
Entry on Page 84

## **E3 Ignition Products**

3210 Valley Ridge Blvd., Ste. 106  
Ponte Vedra, FL 32081  
904-280-0339  
corporate@e3sparkplugs.com  
e3sparkplugs.com  
Category: ENGINE COMPONENTS  
Entry on Page 20

## **ECUMaster USA**

2701 National Circle  
Garland, TX 75041  
817-523-9947  
marketing@ecumasterusa.com  
ecumasterusa.com  
Category: RACING COMPONENTS,  
ACCESSORIES & SERVICES  
Entry on Page 104

## **everyday dev**

5164 Guilford Ave.  
Indianapolis, IN 46205  
720-434-0380  
hello@everydaydev.io  
everydaydev.io  
Category: RACING COMPONENTS,  
ACCESSORIES & SERVICES  
Entry on Page 105

## **Evolution Measurement**

7 Regents Court South Way  
Walworth, Andover SP10 5NX  
United Kingdom  
+44 (0) 7752238556  
enquiries@evolutionmeasurement.com  
evolutionmeasurement.com  
Category: RACING COMPONENTS,  
ACCESSORIES & SERVICES  
Entry on Page 105

## **FANUC America Corporation**

3900 W. Hamlin Rd.  
Rochester Hills, MI 48309  
248-830-3020  
stephen.bond@fanucamerica.com  
fanucamerica.com  
Category: MACHINERY, TOOLS & EQUIPMENT  
Entry on Page 136

## **Fentech Co.**

800 Biltmore Dr.  
Fenton, MO 63026  
crankitup@fentechbalancers.com  
fentechcoinc.com  
Category: MACHINERY, TOOLS & EQUIPMENT  
Entry on Page 136

## **FERTAN**

12485 SW 137th Ave.  
Miami, FL 33186  
305-614-1140  
contact@fertanusa.com  
fertanusa.com  
Category: RACING COMPONENTS,  
ACCESSORIES & SERVICES  
Entry on Page 105

## **FiTech Fuel Injection**

12370 Doherty St., Ste. A  
Riverside, CA 92503  
951-340-2624  
sales@fitechefi.com  
fitechefi.com  
Category: ENGINE COMPONENTS  
Entry on Page 22

## **Flaming River Industries**

800 Poertner Dr.  
Berea, OH 44017  
800-648-8022  
info@flamingriver.com  
flamingriver.com  
Category: RACING COMPONENTS,  
ACCESSORIES & SERVICES  
Entry on Page 106

## **Fluidampr-Vibratex TVD**

180 Zoar Valley Rd.  
Springville, NY 14141  
716-592-1000  
info@fluidampr.com  
fluidampr.com  
Category: ENGINE COMPONENTS  
Entry on Page 48

## **Flying A Motorsports**

3257 E. Outer Rd.  
Scott City, MO 63780  
800-222-4004  
sales@flyingamotorsports.com  
flyingamotorsports.com  
Category: RACING COMPONENTS,  
ACCESSORIES & SERVICES  
Entry on Page 106

## **FOD Control Corporation**

548 Forest Center Plaza  
Garland, TX 75042  
800-425-8363  
pete@fodcontrol.com  
fodcontrol.com  
Category: RACE TRACK EQUIPMENT &  
SUPPLIES  
Entry on Page 147

## **Frenkit Performance**

Poligono Aloa, 15  
Puente La Reina, Int, 31100, Spain  
andy.mayfield@frenkit.es  
frenkit.es  
Category: CHASSIS, DRIVELINE & SUSPENSION  
COMPONENTS  
Entry on Page 84

## **FTI Performance**

1815 Patterson Ave.  
DeLand, FL 32724  
386-736-5816  
info@ftiperformance.com  
ftiperformance.com  
Category: CHASSIS, DRIVELINE & SUSPENSION  
COMPONENTS  
Entry on Page 68

## **Gandrud Parts Center**

919 Auto Plaza Dr.  
Green Bay, WI 54302  
920-468-3658  
cwillkymack@gandrud.com  
gmperformance.com  
Category: ENGINE COMPONENTS  
Entry on Page 48

## **Gastops**

1011 Polytek St.  
Ottawa, ON K1J 9J3  
Canada  
613-744-3530  
swilson@gastops.com  
gastops.com  
Category: RACING COMPONENTS,  
ACCESSORIES & SERVICES  
Entry on Page 106

## **Gearhead Coffee**

1000 N Hwy. 78, Ste. C  
Wylie, TX 75098  
jeff@gearheadcoffee.com  
gearheadcoffee.com  
Category: RACE TRACK EQUIPMENT &  
SUPPLIES  
Entry on Page 147

## **G-FORCE Racing Gear**

4231 Southside Dr., Ste. 300  
Acworth, GA 30101  
mikem@gforce.com  
gforce.com  
Category: RACING COMPONENTS,  
ACCESSORIES & SERVICES  
Entry on Page 107



## **GFX Corp**

4810 NW 74 Ave.  
Miami, FL 33166  
305-499-9789  
sales@gfxcorp.com  
gfxcorp.com  
Category: CHASSIS, DRIVELINE & SUSPENSION  
Entry on Page 70

## **Giant Finishing**

600 W. Factory Rd.  
Addison, IL 60101  
708-343-6900  
sales@giantfinishing.com  
giantfinishing.com  
Category: MACHINERY, TOOLS & EQUIPMENT  
Entry on Page 124

## **Green Filter USA**

2152 University Dr. Rte. 119  
Mt. Braddock, PA 15465  
csr@greenfilter.com  
greenfilter.com  
Category: ENGINE COMPONENTS  
Entry on Page 48

## **Grepow**

290 Lindbergh Ave.  
Livermore, CA 94551  
925-364-7166  
joe@gensace.com, grepow.com  
Category: MACHINERY, TOOLS & EQUIPMENT  
Entry on Page 137

## **Guniwheel**

PO Box 511  
New Hampton, IA 50659  
404-457-4018  
info@guniproductions.com  
guniproductions.com  
Category: MACHINERY, TOOLS & EQUIPMENT  
Entry on Page 137

## **GZERO Additive**

609 Spring St., Ste. C  
Elsmere, KY 41018  
sales@gzeroadditive.com  
gzeroadditive.com  
Category: MACHINERY, TOOLS & EQUIPMENT  
Entry on Page 137

## **Heck Industries**

PO Box 425  
Hartland, MI 48353  
810-632-5400  
heckind@ameritech.net  
woodwardfab.com  
Category: MACHINERY, TOOLS & EQUIPMENT  
Entry on Page 138

## **Heidenhain Corporation**

333 E. State Pkwy.  
Schaumburg, IL 60173  
info@heidenhain.com  
heidenhain.us  
Category: MACHINERY, TOOLS & EQUIPMENT  
Entry on Page 138

## **Hoosier Pattern**

906 N. 10th St.  
Decatur, IN 46733  
260-706-4147  
info@hoosierpattern.com  
hoosierpattern.com  
Category: MACHINERY, TOOLS & EQUIPMENT  
Entry on Page 125

## **Hoosier Racing Tire**

65465 S.R. 931  
Lakeville, IN 46536  
info@hoosiertire.com  
hoosiertire.com  
Category: CHASSIS, DRIVELINE & SUSPENSION  
COMPONENTS  
Entry on Page 85

## **Hot Shot's Secret**

3975 Morrow Meadows Dr.  
Mount Gilead, OH 43338  
800-341-6516  
josh@lubricationspecialties.com  
hotshotsecret.com  
Category: RACING COMPONENTS,  
ACCESSORIES & SERVICES  
Entry on Page 107

## **Howards Cams**

280 W. 35th Ave  
Oshkosh, WI 54902  
920-230-4241  
robert@howardscams.com  
howardscams.com  
Category: ENGINE COMPONENTS  
Entry on Page 48

## **Howe Racing Enterprises**

3195 Lyle Rd.  
Beaverton, MI 48612  
989-435-7080  
howeinfo@howeracing.com  
howeracing.com  
Category: CHASSIS, DRIVELINE & SUSPENSION  
COMPONENTS  
Entry on Page 85

## **Hunter Engineering Co.**

11250 Hunter Dr.  
Bridgeton, MO 63044  
314-731-0000  
contact.hunter@hunter.com  
hunter.com  
Category: MACHINERY, TOOLS & EQUIPMENT  
Entry on Page 138

## **Hypermax Engineering**

255 E. Route 72  
Gilberts, IL 60136  
theresa@gohypermax.com  
gohypermax.com  
Category: ENGINE COMPONENTS  
Entry on Page 48

## **Ididit**

610 S. Maumee St.  
Tecumseh, MI 49286  
517-424-0577  
sales@ididit.com  
ididit.com  
Category: RACING COMPONENTS,  
ACCESSORIES & SERVICES  
Entry on Page 107

## **InEarz Sport**

170 N. Cypress Way  
Casselberry, FL 32707  
407-339-2422  
info@inearz.com  
inearzsport.com  
Category: RACING COMPONENTS,  
ACCESSORIES & SERVICES  
Entry on Page 108

## **InTech Trailers**

29286 Co. Rd. 52  
Nappanee, IN 46550  
574-773-9536  
marketing@intech.com  
intech.com/motorsport-trailers/lite  
Category: RACING COMPONENTS,  
ACCESSORIES & SERVICES  
Entry on Page 108

## **IPG Photonics**

377 Simarano Dr.  
Marlborough, MA 01752  
508-373-1100  
mafoley@ipgphotonics.com  
ipgphotonics.com  
Category: MACHINERY, TOOLS & EQUIPMENT  
Entry on Page 139

## **Irontite Products Kwik-Way Van Norman**

2525 18th St. SW  
Cedar Rapids, IA 52404  
319-377-9421  
service@irontite.com  
irontite.com  
Category: MACHINERY, TOOLS & EQUIPMENT  
Entry on Page 126

## **JackPak by BendPak**

30440 Agoura Rd.  
Agoura Hills, CA 91301  
800-253-2363  
sales@jackpak.com  
jackpak.com  
Category: MACHINERY, TOOLS & EQUIPMENT  
Entry on Page 127

## **Jason Dietsch Trailer Sales**

227 E. Morrison St.  
Edgerton, OH 43517  
419-298-0777  
jenniferd@jdtrailersales.com  
jasondietschtrailersales.com  
Category: RACING COMPONENTS,  
ACCESSORIES & SERVICES  
Entry on Page 108

## **JAZ Products**

1212 E. Santa Paula St.  
Santa Paula, CA 93060  
805-525-8800  
info@jazproducts.com  
jazproducts.com  
Category: RACING COMPONENTS,  
ACCESSORIES & SERVICES  
Entry on Page 109

## **Jesel**

1985 Cedar Bridge Ave., Ste. 2  
Lakewood, NJ 08701  
sales@jesel.com  
jesel.com  
Category: ENGINE COMPONENTS  
Entry on Page 50

## **JMS Performance Group**

240 Springview Commerce Dr., Bldg. 1 - J  
DeBary, FL 32713  
601-766-9424  
f-kondas@jmschip.com  
jmschip.com  
Category: ENGINE COMPONENTS  
Entry on Page 24

# SUPPLIERS INDEX

## **Kelford Cams**

15 Kennaway Rd.  
Christchurch 8023  
New Zealand  
+64 3 929 0725  
sales@kelfordcams.com  
kelfordcams.com  
Category: ENGINE COMPONENTS  
Entry on Page 26

## **Kellymoss Custom Porsche Services**

5105 W. Clayton Rd.  
Fitchburg, WI 53711  
608-274-5054  
info@kellymoss.com  
kellymoss.com  
Category: RACING COMPONENTS,  
ACCESSORIES & SERVICES  
Entry on Page 109

## **Ken Perry's Xtreme Arias**

15 High Tech Blvd.  
Thomasville, NC 27360  
844-777-5792  
ken@kpxaracingengines.com  
kpxaracingengines.com  
Category: ENGINE COMPONENTS  
Entry on Page 50

## **King Racing Products**

2216 E. Mineral King Ave.  
Visalia, CA 93292  
559-636-1655  
blake@brmotorsports.com  
kingracingproducts.com  
Category: ENGINE COMPONENTS  
Entry on Page 50

## **Kirkey Racing Fabrication**

5215 Hwy. #138  
St Andrews W., Ontario, Canada K0C2A0  
800-363-4885  
kirkey@kirkeyracing.com  
kirkeyracing.com  
Category: RACING COMPONENTS,  
ACCESSORIES & SERVICES  
Entry on Page 94

## **Landrum Performance Springs**

4561 S. State Rd. 19  
Mentone, IN 46539  
866-703-3154  
sales@landrumspring.com  
landrumspring.com  
Category: CHASSIS, DRIVELINE & SUSPENSION  
COMPONENTS  
Entry on Page 85

## **Larsen Racing Products**

445 Sprauer Rd.  
Petaluma, CA 94952-8101  
randy@larsenracingproducts.com  
larsenracingproducts.com  
Category: CHASSIS, DRIVELINE & SUSPENSION  
COMPONENTS  
Entry on Page 86

## **Larson Systems**

13847 Aberdeen St. NE  
Ham Lake, MN 55304  
763-780-2131  
triton.stellflug@larsonsystems.com  
larsonsystems.com  
Category: MACHINERY, TOOLS & EQUIPMENT  
Entry on Page 139

## **LAT Racing Oils**

2366 N. Glassell St., Ste. G  
Orange, CA 92865  
714-341-1241  
contact@latracingoils.com  
latracingoils.com  
Category: RACING COMPONENTS,  
ACCESSORIES & SERVICES  
Entry on Page 95

## **Late Model Engines**

1930 Aldine Western Rd.  
Houston, TX 77038  
713-849-4505  
collin@latemodelengines.com  
latemodelengines.com  
Category: ENGINE COMPONENTS  
Entry on Page 50

## **Lear Chemical Research Corp.**

6182 A Kestrel Rd.  
Mississauga, ON L5T1Z2  
Canada  
905-564-0018  
info@learchem.com  
learchem.com  
Category: RACING COMPONENTS,  
ACCESSORIES & SERVICES  
Entry on Page 109

## **Lifeline USA**

1016 Memorial Dr.  
Pulaski, VA 24301  
540-251-2724  
brandon@lifeline-fire.com  
lifeline-fire.com  
Category: RACING COMPONENTS,  
ACCESSORIES & SERVICES  
Entry on Page 110

## **LITESTIX by BendPak**

30440 Agoura Rd.  
Agoura Hills, CA 91301  
800-253-2363  
sales@bendpak.com  
bendpak.com  
Category: MACHINERY, TOOLS & EQUIPMENT  
Entry on Page 128

## **MAGIDO USA**

1500 S. Sylvania Ave., Ste. 101  
Sturtevant, WI 53177  
844-462-4436  
sales@magidouusa.com  
magidouusa.com  
Category: MACHINERY, TOOLS & EQUIPMENT  
Entry on Page 139

## **MAHLE Aftermarket**

23030 Mahle Dr.  
Farmington Hills, MI  
947-944-5592  
alyssa.mcgee@mahle.com  
mahle-aftermarket.com  
Category: ENGINE COMPONENTS  
Entry on Page 50

## **MAHLE Motorsports**

270 Rutledge Rd., Ut. C  
Fletcher, NC 28732  
888-255-1942  
scott.clontz@mahle.com  
mahlemotorsports.com  
Category: ENGINE COMPONENTS  
Entry on Page 50

## **ManualBrakes.com**

11531 Earley Forest Ln.  
Houston, TX 77043  
david.schultz@manualbrakes.com  
manualbrakes.com  
Category: CHASSIS, DRIVELINE & SUSPENSION  
COMPONENTS  
Entry on Page 86

## **Masta Performance**

441 Jeni Ln.  
Milford, MI 48380  
248-685-8710  
mastaperformance@gmail.com  
mastaperformance.com  
Category: ENGINE COMPONENTS  
Entry on Page 52

## **Masters Entertainment Group**

907 Hwy. 126  
Bristol, TN 37620  
423-968-7736  
dave@masterstv.com  
masterstv.com  
Category: RACING COMPONENTS,  
ACCESSORIES & SERVICES  
Entry on Page 110

## **Maxima Racing Oils**

9263 Abraham Way  
Santee, CA 92071  
619-449-5000  
customersupport@maximausa.com  
maximausa.com  
Category: RACING COMPONENTS,  
ACCESSORIES & SERVICES  
Entry on Page 96

## **MaxJax by BendPak**

5240 Willis Rd.  
Theodore, AL 36582  
844-629-5291  
sales@maxjax.com  
maxjax.com  
Category: MACHINERY, TOOLS & EQUIPMENT  
Entry on Page 129

## **MB Quart**

851 E. Park Ave.  
Libertyville, IL 60442  
847-540-7700  
info@maxxsonics.com  
mbquart.com  
Category: RACING COMPONENTS,  
ACCESSORIES & SERVICES  
Entry on Page 110

## **McLeod Racing**

1570 Lakeview Loop  
Anaheim, CA 92807  
714-630-2764  
info@mcleodracing.com  
mcleodracing.com  
Category: CHASSIS, DRIVELINE & SUSPENSION  
COMPONENTS  
Entry on Page 72

## **Melling Performance**

2620 Saradan Dr.  
Jackson, MI 49202  
517-787-8172  
melling.com  
Category: ENGINE COMPONENTS  
Entries on Pages 28 & 30

## **Mityvac**

5148 N. Hanley Rd.  
St. Louis, MO 63134  
314-679-4200  
mityvacsales@skf.com  
mityvac.com  
Category: MACHINERY, TOOLS & EQUIPMENT  
Entry on Page 140

## **Molecule**

232 Avenida Fabricante, Ut. 102  
San Clemente, CA 92672  
949-429-6706  
info@moleculesports.com  
moleculesports.com  
Category: RACING COMPONENTS,  
ACCESSORIES & SERVICES  
Entry on Page 111

## **Molnar Technologies**

4101 40th St. SE, Ste. 2  
Kentwood, MI 49512  
616-940-4640  
sales@molnartechnologies.com  
molnartechnologies.com  
Category: ENGINE COMPONENTS  
Entry on Page 32

## **MoTeC**

235 Raceway Dr.  
 Mooresville, NC 28117  
704-799-3000  
sales@motec.com  
motec.com  
Category: RACING COMPONENTS,  
ACCESSORIES & SERVICES  
Entry on Page 111

## **MRCOOL**

48 Remington Way  
Hickory, KY 42051  
270-366-0457  
mrcool.com  
Category: MACHINERY, TOOLS & EQUIPMENT  
Entry on Page 130

## **MustangSteve**

1701 Melissa Ln.  
Cleburne, TX 76031  
sales@mustangsteve.com  
mustangsteve.com  
Category: CHASSIS, DRIVELINE & SUSPENSION  
COMPONENTS  
Entry on Page 86

## **Nitrous Express**

5411 Seymour Hwy.  
Wichita Falls, TX 76310  
940-767-7694  
sales@nitrousexpress.com  
nitrousexpress.com  
Category: ENGINE COMPONENTS  
Entry on Page 52

## **Northern Radiator**

2701 Fourth Ave. SW  
Willmar, MN 56201  
800-328-8900  
marketing@northernradiator.com  
northernradiator.com  
Category: ENGINE COMPONENTS  
Entry on Page 52

## **Online Resources**

125 N. West St.  
Lebanon, IN 46052  
765-482-9700, ext. 75  
kristy@onlineresourcesinc.com  
onlineresourcesinc.com  
Category: MACHINERY, TOOLS & EQUIPMENT  
Entry on Page 140

## **OptiTorque Technologies**

1B Powell Ln.  
Penn Yan, NY 14527  
315-924-3888  
optitorque.com  
Category: ENGINE COMPONENTS  
Entry on Page 34

## **Outerwears**

12611 US Hwy. 131  
Schoolcraft, MI 49087  
269-679-3301  
nick@outerwears.com  
outerwears.com  
Category: ENGINE COMPONENTS  
Entry on Page 52

## **P1 Manufacturing**

11 White Oak Rd.  
Rogersville, MO 65742  
417-753-5174  
mcampbell@p1mfg.com  
p1mfg.com  
Category: ENGINE COMPONENTS  
Entry on Page 52

## **Pacific Performance Engineering**

3679 Civic Center Dr.  
North Las Vegas, NV 89030  
725-238-2002  
allan.bautista@ppepower.com  
ppepower.com  
Category: ENGINE COMPONENTS  
Entry on Page 52

## **Palmgren**

2000 N. Aurora Rd.  
Naperville, IL 60563  
800-827-3398  
sales@chhanson.com  
palmgren.com  
Category: MACHINERY, TOOLS & EQUIPMENT  
Entry on Page 131

## **Performance Distributors**

2699 Barris Dr.  
Memphis, TN 38132  
901-396-5782  
info@performancedistributors.com  
performancedistributors.com  
Category: ENGINE COMPONENTS  
Entry on Page 54

## **Performance Driveline Engineering**

22824 Morelli Dr.  
Clinton Township, MI 48036  
248-761-3247  
steve@pdedriveshafts.com  
pdedriveshafts.com  
Category: CHASSIS, DRIVELINE & SUSPENSION  
COMPONENTS  
Entry on Page 87

## **Performance Electronics**

11529 Goldcoast Dr.  
Cincinnati, OH 45249  
show\_coord@pe-ltd.com  
pe-ltd.com  
Category: RACING COMPONENTS,  
ACCESSORIES & SERVICES  
Entry on Page 111

## **Performance Engineering & Manufacturing**

425 Industrial Park Dr.  
Saint Clair, MO 63077  
636-629-6200  
sales@pemracing.com  
pemracing.com  
Category: CHASSIS, DRIVELINE & SUSPENSION  
COMPONENTS  
Entry on Page 87

## **Performance Plus Global Logistics**

942 Hemsath Rd.  
St. Charles, MO 63303  
866-966-7587  
info@pplusglobal.com  
pplusglobal.com  
Category: RACING COMPONENTS,  
ACCESSORIES & SERVICES  
Entry on Page 97

## **Permatex**

6875 Parkland Blvd.  
Solon, OH 44139  
440-248-6120  
stefanie.cooper@permatex.com  
permatex.com  
Category: ENGINE COMPONENTS  
Entry on Page 54

## **Peterson Fluid Systems**

14331 Hilltop Rd.  
Longmont, CO 80504  
303-287-1731  
pfsinfo@specprod.com  
petersonfluidsys.com  
Category: ENGINE COMPONENTS  
Entry on Page 36

## **Piper Cams**

Units 5 & 6, Bowles Well Gardens  
Folkestone, Kent, CT19 6PQ  
United Kingdom  
+44 (0) 1303 245300  
sales@pipercams.co.uk  
pipercams.co.uk  
Category: ENGINE COMPONENTS  
Entry on Page 54

## **Portatree Timing Systems**

594 Blackstone St.  
Uxbridge, MA 01569  
508-278-2189  
info@portatree.com  
portatree.com  
Category: RACING COMPONENTS,  
ACCESSORIES & SERVICES  
Entry on Page 112

## **Powermaster Performance**

1833 Downs Dr.  
West Chicago, IL 60185  
denisel@powermasterperformance.com  
powermasterperformance.com  
Category: ENGINE COMPONENTS  
Entry on Page 55

# SUPPLIERS INDEX

THE BUSINESS  
OF RACING  
STARTS HERE



**ADVERTISE  
TODAY**  
IN THE  
INDUSTRY'S  
LEADING B2B  
MAGAZINE!

To learn about your advertising options in PRi Magazine, go to [performanceracing.com/advertising](http://performanceracing.com/advertising) or contact us today at 949/499-5413



## POWERtube TV

15365 Navion Dr.  
Port Saint Lucie, FL 34987  
214-810-6142  
contact@watchpowertubetv.com  
watchpowertubetv.com  
Category: RACING COMPONENTS,  
ACCESSORIES & SERVICES  
Entry on Page 112

## Precision Racing Components

140 Gasoline Alley  
Indianapolis, IN 46222  
317-248-4764  
chris.sumner@prc-mfg.com  
prc-mfg.com  
Category: ENGINE COMPONENTS  
Entry on Page 55

## Pro Ultrasonics

3100 NC 18 US 64  
Morganton, NC 28655  
828-584-1005  
info@proultrasonics.com  
proultrasonics.com  
Category: MACHINERY, TOOLS & EQUIPMENT  
Entry on Page 140

## ProCharger Supercharger Systems

14801 W. 114th Terr.  
Lenexa, KS 66215  
913-338-2886  
marketing@procharger.com  
procharger.com  
Category: ENGINE COMPONENTS  
Entry on Page 55

## PROFORM Parts

26708 Groesbeck Hwy.  
Warren, MI 48089  
586-774-2500  
proformparts.com  
Category: ENGINE COMPONENTS  
Entry on Page 38

## PRW Power

1722 Illinois Ave.  
Perris, CA 92571  
310-863-0569  
mike@prwpower.com  
PRW-USA.com  
Category: ENGINE COMPONENTS  
Entry on Page 56

## PureForge Brakes

40 W. Pike St.  
Pontiac, MI 48342  
248-481-7096  
info@pureforge.com  
pureforge.com  
Category: CHASSIS, DRIVELINE & SUSPENSION  
COMPONENTS  
Entry on Page 87

## Quantum Machinery Group

7110 Expo Dr., Ste. D  
Charlotte, NC 28269  
704-703-9400  
albert@quantummachinery.com  
quantummachinery.com  
Category: MACHINERY, TOOLS & EQUIPMENT  
Entry on Page 141

## QuickJack by BendPak

250 Dove Ct.  
Santa Paula, CA 93060  
888-262-3880  
sales@quickjack.com  
quickjack.com  
Category: MACHINERY, TOOLS & EQUIPMENT  
Entry on Page 132

## Quick Time Performance

194 Old Roebuck Rd.  
Moore, SC 29369  
864-913-1999  
sales@quicktimeperformance.com  
quicktimeperformance.com  
Category: ENGINE COMPONENTS  
Entry on Page 56

## RACEceiver

872 Main St. SW, D-2  
Gainesville, GA 30501  
770-287-8544  
sales@raceceiver.com  
raceceiver.com  
Category: RACE TRACK EQUIPMENT &  
SUPPLIES  
Entry on Page 146

## Racetech Seats

3611 Challenger Way  
Carson City, NV 89706  
704-450-4507  
sales@racetech-usa.com  
racetech-usa.com  
Category: RACING COMPONENTS,  
ACCESSORIES & SERVICES  
Entry on Page 112

## Racing Electronics

555 MRN Dr. NW  
Concord, NC 28027  
re-support@racingelectronics.com  
racingelectronics.com  
Category: RACING COMPONENTS,  
ACCESSORIES & SERVICES  
Entry on Page 113

## Raxwell

20 Fairbanks, Ste. 173  
Irvine, CA 92618  
marketing@raxwellindustries.com  
raxwellindustries.com  
Category: RACE TRACK EQUIPMENT &  
SUPPLIES  
Entry on Page 147

## Raybestos Powertrain

711 Tech Dr.  
Crawfordsville, IN 47933  
info@raybestospowertrain.com  
raybestospowertrain.com  
Category: CHASSIS, DRIVELINE & SUSPENSION  
COMPONENTS  
Entry on Page 88

## RC Trailers

51790 County Rd. 39  
Middlebury, IN 46540  
574-825-9518  
melissa.hahn@rctrailers.com  
rctrailers.com  
Category: RACING COMPONENTS,  
ACCESSORIES & SERVICES  
Entry on Page 113

### Remflex Exhaust Gaskets

PO Box 170  
Mineral, WA 98355  
866-641-7325  
info@remflex.com  
remflex.com  
Category: ENGINE COMPONENTS  
Entry on Page 40

### RMC Engine Rebuilding Equipment

5775 Bridgeview Ctr.  
Saginaw, MI 48604  
989-754-3611  
mattn@rmcengine.com  
rmcengine.com  
Category: MACHINERY, TOOLS & EQUIPMENT  
Entry on Page 141

### RW Thompson

3715 Harrison Rd., Ste. 500  
Loganville, GA 30052  
770-979-1997  
support@knkut.com  
knkut.com  
Category: MACHINERY, TOOLS & EQUIPMENT  
Entry on Page 141

### S&S Diesel Motorsport

1471 W. Tipton St.  
Seymour, IN 47274  
812-521-0123  
info@ssdiesel.com  
ssdiesel.com  
Category: ENGINE COMPONENTS  
Entry on Page 56

### SBI

2108 Utopia Ave.  
Nashville, TN 37211  
615-248-6281  
sbi-customerservice@sbintl.com  
sbintl.com  
Category: ENGINE COMPONENTS  
Entry on Page 42

### SCE Gaskets

424 William Springs Rd.  
Mt. Pleasant, TN 38474  
ashleyh@scegaskets.com  
scegaskets.com  
Category: ENGINE COMPONENTS  
Entry on Page 57

### Schaeffer Manufacturing Co.

2600 S Broadway  
St. Louis, MO 63118  
314-865-4100  
schaefferoil.com  
Category: RACING COMPONENTS,  
ACCESSORIES & SERVICES  
Entry on Page 98

### Schumann's Sales & Service

PO Box 128  
Blue Grass, IA 52726  
563-381-2416  
schumannssalesandservice.com  
Category: ENGINE COMPONENTS  
Entry on Page 57

### Scribner Plastics

11455 Hydraulics Dr.  
Rancho Cordova, CA 95742  
916-638-1515  
chris@scribnerplastics.com  
scribnerplastics.com  
Category: RACING COMPONENTS,  
ACCESSORIES & SERVICES  
Entry on Page 113

### ShopSabre CNC

21673 Cedar Ave.  
Lakeville, MN 55044  
952-461-4570  
sales@shopsabre.com  
shopsabre.com  
Category: MACHINERY, TOOLS & EQUIPMENT  
Entry on Page 142

### Shuriken by Metra Electronics

460 Walker St.  
Holly Hill, FL 32117  
386-257-1186  
sales@metra-autosound.com  
metraonline.com  
Category: RACING COMPONENTS,  
ACCESSORIES & SERVICES  
Entry on Page 114

### Silver Sport Transmissions

2250 Stock Creek Blvd.  
Rockford, TN 37853  
865-609-8187  
info@shiftsst.com  
shiftsst.com  
Category: CHASSIS, DRIVELINE & SUSPENSION  
Entry on Page 74

### Slade Precision Shocks

4115 Eagleville Rd.  
Fostoria, OH 44830  
704-232-1127  
info@sladeprecisionshocks.com  
sladeprecisionshocks.com  
Category: CHASSIS, DRIVELINE & SUSPENSION  
Entry on Page 76

### Sonnax

2 Imtec Ln.  
Bellows Falls, VT 05101  
802-463-9722  
gregg.nader@sonnax.com  
sonnax.com  
Category: CHASSIS, DRIVELINE & SUSPENSION  
COMPONENTS  
Entry on Page 88

### Southern Adrenaline

5001 E FM 1187, Ut. 210  
Burlleson, TX 76028  
817-371-2350  
sarah.southernadrenaline@gmail.com  
southernadrenaline.net  
Category: RACING COMPONENTS,  
ACCESSORIES & SERVICES  
Entry on Page 114

### SPAL Automotive USA

1731 SE Oralabor Rd.  
Ankeny, IA 50021  
800-345-0327  
info@spalusa.com  
spalusa.com  
Category: ENGINE COMPONENTS  
Entry on Page 57

# Tie Down brackets



**If you have CalTracs,  
you have Tie Down Points**

**EASY TO INSTALL/EASY TO ACCESS**  
Designed to bolt onto your CalTracs  
Mounts. Two styles available:  
45° angle, 90° angle  
1/4" Zinc-Plated Steel to resist rust Overall  
size: 5-1/8" x 4", Hook/Strap Hole 1-3/8"  
NOTE: Does not include straps.

**2024 AT FULL THROTTLE  
CALVERT  
RACING**

**CalvertRacing.com**

ASK A TECH:  
**661-728-9600**  
Hours: M-F 8am-4:30pm PST



MADE IN THE USA

## SRC SAMPSON RACING COMMUNICATIONS



**MOTOROLA SOLUTIONS** NO MORE STATIC!!!

**Complete Digital System ONLY \$899**

**Extra Crew ONLY \$399**



SameDay Shipping with Phone and Live Video Tech/Sales Support

[www.sampsonracing.com](http://www.sampsonracing.com) / 866.396.7231

## ROBINS Signature brand SINCE 1993

Now Introducing...

**Premium Multi-angle valve seat inserts:**

Suitable for:

- Powder Metal and hardened Valve Seats 60 HRC & above.
- Over 400 multi angle profiles to choose from.



**Get Double the Life!**

**RUBi-hard PLUS**

[www.RobinsMachines.com](https://www.RobinsMachines.com)

[www.RobinsMachines.com](https://www.RobinsMachines.com)

# SUPPLIERS INDEX



PRISHOW.COM/SOCIAL

# CONNECT

**PRI**  
PERFORMANCE RACING INDUSTRY

## **Stainless Works**

10145 Philipp Pkwy.  
Streetsboro, OH 44241  
800-878-3635  
marketing@stainlessworks.net  
stainlessworks.net  
Category: ENGINE COMPONENTS  
Entry on Page 58

## **Steering Buddy**

4511 Oakwood Dr.  
Anniston, AL 36206  
mikepearl8@yahoo.com  
steeringbuddy.com  
Category: RACING COMPONENTS,  
ACCESSORIES & SERVICES  
Entry on Page 114

## **STKR Concepts**

116 Burry Ct.  
Troutman, NC 28166  
704-508-1031  
business@stkrconcepts.com  
b2b.stkrconcepts.com  
Category: MACHINERY, TOOLS & EQUIPMENT  
Entry on Page 142

## **Stroud Safety**

4101 S. May Ave.  
Oklahoma City, OK 73119  
405-632-2022  
john@stroudsafety.com  
stroudsafety.com  
Category: RACING COMPONENTS,  
ACCESSORIES & SERVICES  
Entry on Page 115

## **Sunnen Products Co.**

7910 Manchester Rd.  
St. Louis, MO 63143  
800-325-3670  
marketing@sunnen.com  
sunnen.com  
Category: MACHINERY, TOOLS & EQUIPMENT  
Entry on Page 133

## **Superior Bearing & Supply**

2505 12th Ave. W.  
Bradenton, FL 34205  
800-423-5318  
andrea@superiorbearings.com  
superiorbearings.com  
Category: MACHINERY, TOOLS & EQUIPMENT  
Entry on Page 142

## **Swift Springs USA**

15330 Fairfield Ranch Rd., Ste. I  
Chino Hills, CA 91709  
909-393-8623  
marketing@swiftsprings.com  
swiftsprings.com  
Category: CHASSIS, DRIVELINE &  
SUSPENSION COMPONENTS  
Entry on Page 88

## **T&D Machine Products**

4859 Convair Dr.  
Carson City, NV 89706  
775-884-2292  
phil@tdmach.com  
tdmach.com  
Category: ENGINE COMPONENTS  
Entry on Page 58

## **Taiwan Racing Products Co.**

No. 3-27, Dalun Rd, Tatsun Hsiang  
Changhua Hsien, Taiwan 51544  
+886-4-853-7046  
tai.racing@beltenick-trp.com  
beltenick-trp.com  
Category: RACING COMPONENTS,  
ACCESSORIES & SERVICES  
Entry on Page 115

## **Technocraft Cabinets**

1540 N. Main  
Mt Pleasant, TN 38474  
931-379-5500  
sales@trailer cabinets.com  
trailer cabinets.com  
Category: RACING COMPONENTS,  
ACCESSORIES & SERVICES  
Entry on Page 115

## **Thermo-Tec Automotive**

PO Box 96  
Greenwich, OH 44837  
800-274-8437  
info@thermotec.com  
thermotec.com  
Category: RACING COMPONENTS,  
ACCESSORIES & SERVICES  
Entry on Page 99

## **Thread Kits Co.**

16900 S. Main St.  
Gardena, CA 90248  
310-891-1995  
jamie@threadkits.com  
threadkits.com  
Category: MACHINERY, TOOLS & EQUIPMENT  
Entry on Page 142

## **Tierra Tech USA**

1111 E. Whitewing Ave.  
McAllen, TX 78501  
956-584-2277  
adminttusa@tierratech.com  
tierratech.com  
Category: MACHINERY, TOOLS & EQUIPMENT  
Entry on Page 143

## **Tilton Engineering**

25 Easy St.  
Buellton, CA 93427-9566  
805-688-2353 (113)  
kirks@tiltonracing.com  
tiltonracing.com  
Category: CHASSIS, DRIVELINE &  
SUSPENSION COMPONENTS  
Entry on Page 89

## **Top Street Performance**

15050 Shoemaker Ave.  
Santa Fe Springs, CA 90670  
562-926-5858  
support@topstreetperformance.com  
topstreetperformance.com  
Category: ENGINE COMPONENTS  
Entry on Page 58

## **Torco International Corp.**

5550 E. Jurupa St., #B  
Ontario, CA 91761  
909-980-1495  
tscott@torcousa.com  
torcousa.com  
Category: RACING COMPONENTS,  
ACCESSORIES & SERVICES  
Entry on Page 116

#### Trailer Alarms

301 Main Plaza, #241  
New Braunfels, TX 78130  
877-604-7381  
traileralarms@yahoo.com  
trailer-alarms.com  
Category: RACING COMPONENTS,  
ACCESSORIES & SERVICES  
Entry on Page 116

#### Ultra Shield Race Products

19313 Hwy. 69 S.  
Flint, TX 75762  
903-894-3550  
mandy@ultrashieldrace.com  
ultrashieldrace.com  
Category: RACING COMPONENTS,  
ACCESSORIES & SERVICES  
Entry on Page 116

#### United Engine & Machine Co.

1040 Corbett St.  
Carson City, NV 89706  
775-882-7790  
tech@uempistons.com  
uempistons.com  
Category: ENGINE COMPONENTS  
Entry on Page 58

#### United Trailers

19985 County Road 8  
Bristol, IN 46507  
800-637-2592  
tdietsch@united-trailers.com  
united-trailers.com  
Category: RACING COMPONENTS,  
ACCESSORIES & SERVICES  
Entry on Page 117

#### VBOX Motorsport

40000 Grand River, Ste. 100  
Novi, Michigan 48375  
248-994-9050  
sales@racelogic.com  
vboxmotorsport.com  
Category: RACING COMPONENTS,  
ACCESSORIES & SERVICES  
Entry on Page 117

#### Vortex Weather Insurance

7400 W. 132nd St., Ste. 260  
Overland Park, KS 66213  
866-997-2469  
info@vortexinsurance.com  
vortexinsurance.com  
Category: RACING COMPONENTS,  
ACCESSORIES & SERVICES  
Entry on Page 117

#### VP Racing Fuels

10205 Oasis St.  
San Antonio, TX 78216  
702-241-3331  
ashlee.phillips@vpracingfuels.com  
vpracingfuels.com  
Category: RACING COMPONENTS,  
ACCESSORIES & SERVICES  
Entry on Page 118

#### Walton Co.

600 New Park Ave.  
West Hartford, CT 06110  
860-523-5231  
sales@waltontools.com  
waltontools.com  
Category: MACHINERY, TOOLS & EQUIPMENT  
Entry on Page 143

#### Webco Industries

3301 W. Hwy. 51  
Sand Springs, OK 74063  
918-245-2211  
carbon\_mechanical@webcotube.com  
webcotube.com  
Category: CHASSIS, DRIVELINE &  
SUSPENSION COMPONENTS  
Entry on Page 89

#### Weld Racing

6600 Stadium Dr.  
Kansas City, MO 64129  
800-788-9353  
weldracing.com  
Category: CHASSIS, DRIVELINE &  
SUSPENSION COMPONENTS  
Entry on Page 78

#### Wieland

4803 Olympia Park Plz.  
Louisville, KY 40241  
708-385-7000  
wieland-metalservices.com  
Category: RACING COMPONENTS,  
ACCESSORIES & SERVICES  
Entry on Page 100

#### XRP

5630 Imperial Hwy.  
South Gate, CA 90280  
562-861-4765  
sales@xrp.com  
xrp.com  
Category: RACING COMPONENTS,  
ACCESSORIES & SERVICES  
Entry on Page 118

#### YourDyno

Solkroken 16A  
1394 Nesbru, Norway  
Kevin: 603-491-5961/Jostein: +47 4840 1279  
kevin@yourdyno.com/jostein@yourdyno.com  
yourdyno.com  
Category: MACHINERY, TOOLS & EQUIPMENT  
Entry on Page 134

#### Zamp

251 NW 13th Pl., Ste. 120  
Meridian, ID 83642  
208-506-3030  
support@zamp-racing.com  
zamp-racing.com  
Category: RACING COMPONENTS,  
ACCESSORIES & SERVICES  
Entry on Page 119

#### ZyCoat

15032 W. 117th St.  
Olathe, KS 66062  
913-599-2600  
tmac@hushmat.com  
zycoat.com  
Category: RACING COMPONENTS,  
ACCESSORIES & SERVICES  
Entry on Page 119

## VISIT THE PERFORMANCE RACING INDUSTRY WEBSITE

LEARN MORE ABOUT:  
TRADE SHOW  
MEMBERSHIP  
MAGAZINE  
ADVERTISING

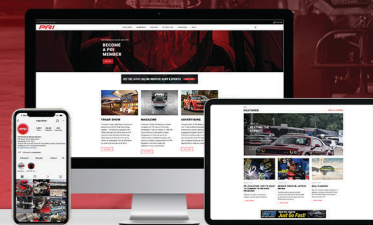

# PRI

PERFORMANCERACING.COM

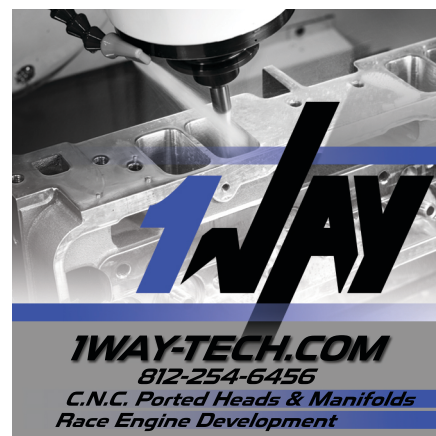

## IWAY-TECH.COM

812-254-6456

C.N.C. Ported Heads & Manifolds  
Race Engine Development



864.580.1858

OWNER OF THE CV PRODUCTS BRAND

CV RACING  
PRODUCTS



cantrellracingproducts@gmail.com

# PERFORMANCE INDUSTRY REPS

2019 SEMA REP OF THE YEAR AWARD (7 TIME RECIPIENT)   2019 CAN REP OF THE YEAR AWARD (2 TIME RECIPIENT) 

WITH OVER 50 YEARS OF EXPERIENCE & EXPERT STAFF OF 26, WE PROVIDE SALES & MARKETING SERVICES TO ALL FACETS OF THE AUTOMOTIVE AFTERMARKET INDUSTRY.

SALES | MARKETING | ADVERTISING | BRAND MANAGEMENT  
 MEDIA SERVICES DATA MANAGEMENT | PROMOTIONAL ADMINISTRATION | EVENT COVERAGE



4094 PIONEER DRIVE | WALLED LAKE, MI 48390  
 P 248.360.2700 F 248.360.3704 KUNZMAN.COM  MIDWEST | MINK | NORTHEAST | SOUTHEAST | WEST COAST | CANADA

*Team*  **CSM**  
**CONSIDINE SALES & MARKETING**

MANUFACTURERS REPRESENTATIVES SERVING AS YOUR FIELD SALES FORCE

CALL: JIM CONSIDINE  
 (248) 889-7887  
 611 S. Milford Rd.  
 Highland, Michigan  
 jconsider@considinesales.com

CELEBRATING **50** YEARS  
 Of Excellence In The Automotive Aftermarket  
 "AWARDED" SEMA REPS OF THE YEAR

- STREET
- RACE
- TRUCK
- OFF-ROAD
- JEEP
- FLEET

   
**NTEA** MEMBER

**WINNING SALES GROWING AWARENESS**  **SLAI**  
 SCOTT LEWIS ASSOCIATES INC.

**Fully-Integrated Marketing & Sales**

Brand Messaging      SEO/SEM Consulting  
 Audience Analysis      Sales Prospecting  
 Collateral Creation      Strategic Partnerships

 **Let's Win Together—Contact Us Now!**  
 (516) 378-6100  
 info@scottlewisinc.com  
 scottlewisinc.com

READ PRI'S MISSION STATEMENT AT  
**PERFORMANCERACING.COM/MISSION**  
 AND SEND US YOUR FEEDBACK.

THE BUSINESS OF RACING STARTS HERE



**ADVERTISE TODAY**  
 IN THE INDUSTRY'S LEADING B2B MAGAZINE!

To learn about your advertising options in PRI Magazine, go to [performanceracing.com/advertising](http://performanceracing.com/advertising) or contact us today at 949/499-5413





# AD INDEX

1 WAY TECHNOLOGIES .....	183
ADVANCED CLUTCH TECHNOLOGY INC. ....	37
ADVANCED SLEEVE .....	166
AIRHEART SALES .....	185
ALL-MIDWEST SALES, LLC .....	185
AMERICAN MAX SPEED TUNING TECHNOLOGY. ....	104
ARMSTRONG RACE ENGINEERING INC. ....	106
ATC TRAILERS .....	77
ATECH MOTORSPORTS .....	71
ATL RACING FUEL CELLS .....	136
AUROBAY .....	86
AUTOMOTIVE RACING PRODUCTS INC. ....	73
BALLARD & ALLEN MARKETING INC. ....	185
BEHRENT'S PERFORMANCE WAREHOUSE. ....	142
BILL MITCHELL HARDCORE RACING PRODUCTS .....	118,170
BOB COOK SALES .....	185
BOKER'S INC. ....	138
BRASWELL CARBURETION .....	171
BRIAN TOOLEY RACING .....	102
BRODIX INC. ....	33
BURDICKS RV CENTER .....	55
CALLIES PERFORMANCE PRODUCTS INC. ....	67
CALVERT RACING SUSPENSIONS. ....	156,160,162
CAM MOTION .....	58
CECOMP ELECTRONICS .....	166
CHAMP PANS .....	163
CHE PRECISION .....	109
CIRCLE D SPECIALTIES .....	91
CLARENDON SPECIALTY FASTENERS INC. ....	172
COMEC INC. ....	65
COMETIC GASKET INC. ....	166
CONSIDINE SALES & MARKETING .....	184
CP-CARRILLO INC. ....	163
CRP CANTRELL RACING PRODUCTS LLC .....	183

# PERFORMANCE INDUSTRY REPS



**BOB COOK SALES**  
SALES & BRAND CONSULTANTS

 **901-854-4632**

 **www.bobcooksales.com**

 **lesrudd@bobcooksales.com**

**NEXT LEVEL BRANDING**



**Ballard Allen**  
MARKETING, INC.

*Performance....*  
**We build our business on it**

**WWW.BALLARDALLEN.COM**

Corporate Office:  
711 W. 17th Street Suite F7  
Costa Mesa, CA 92627  
P: 949.722.7716 F: 949.722.7957

ADDITIONAL REGIONAL OFFICES SERVICING YOU  
LINCOLN, CA - DENVER, CO - PORTLAND, OR - PHOENIX, AZ

**We are here to service your business**  
**in the Western 11 States and Western Canada**



SERVICING THE  
PERFORMANCE TRUCK & DIESEL MARKETS  
IN PENNSYLVANIA • NEW YORK • NEW JERSEY  
MARYLAND • DELAWARE • NEW ENGLAND  
EASTERN CANADA

**CONTACT: ADAM OLSON**  
14 MEADE LANE  
ENFIELD, CT 06082  
PHONE: 860.698.6022  
AOLSON@PROREPMARKETING.COM

VISIT US AT: [WWW.PROREPMARKETING.COM](http://WWW.PROREPMARKETING.COM)



**Thomas Sales and Marketing**

Specialists in the Performance, Automotive, Heavy Duty,  
Diesel, Agricultural and Industrial Markets.

Central Office:  
317-846-7024  
Ron.thomasco@sbcglobal.net

Indiana, Illinois,  
Kentucky, Michigan, Ohio,  
West Virginia,  
Pennsylvania, Wisconsin.

[www.thomassalesco.com](http://www.thomassalesco.com)



**AIRHEART SALES**  
"the Performance Reps"  
Jim Link Ph. 425.888.2540

**Branch Offices**  
Ladera Ranch, CA • North Bend, WA • Portland OR,  
Newport Beach, CA • El Paso, TX • Edmonton, Canada

**Territory:** AZ, CA, CO, ID, MT, NM, NV,  
OR, TX, UT, WA, West Canada  
[www.airheartsales.com](http://www.airheartsales.com)



**KAM MARKETING**  
MANUFACTURERS REPRESENTATIVE  
*There's No Substitute for Experience & Integrity*

**PERFORMANCE SPECIALISTS**

**Bernie Meyer** : [bernie@kammarketing.com](mailto:bernie@kammarketing.com)  
(302) 658-7778  
6 Ponds Edge Dr, Ste 2  
Chadds Ford, PA 19317

[KamMarketing.com](http://KamMarketing.com)



**ALL-MIDWEST SALES**



**2111 Lanterman Circle • Hinckley, Ohio 44233 • 216-225-4564 • [j.morehouse@att.net](mailto:j.morehouse@att.net)**

Over 55 Years of professional representation of premier companies to all levels of  
distribution in the Specialty Automotive Aftermarket

[www.allmidwestsales.com](http://www.allmidwestsales.com)

# AD INDEX

CTECH MANUFACTURING .....	39	LEAR CHEMICAL RESEARCH CORP. ....	140	SANDER ENGINEERING. ....	56
DAIDO ENGINE BEARINGS .....	84,157	LINEZLINE COATINGS .....	158	SB INTERNATIONAL INC. ....	61
DARTON INTERNATIONAL INC. ....	43	M2 BRANDWEAR .....	165	SCHAEFFER MANUFACTURING CO. ....	2
DAYCO .....	110	MAHLE AFTERMARKET INC. ....	45	SCHUMANN'S SALES & SERVICE .....	137
DESIGN ENGINEERING INC. ....	57	MAHLE MOTORSPORTS INC. ....	143	SCOGGIN DICKEY CHEVROLET .....	118
DISCOVERY CARGO TRAILERS INC. ....	115	MASTA PERFORMANCE INC. ....	160	SCOTT LEWIS ASSOCIATES INC. ....	184
DYERS TOP RODS .....	140	MAXXSONICS USA .....	47	SCS GEARBOX INC. ....	139
DYNABRADE INC. ....	41	MILODON INC. ....	153,167	SERDI CORP. ....	112
EFILIVE LTD. ....	75	MOLNAR TECHNOLOGIES LLC .....	172	SETRAB USA .....	139
ENERGY MANUFACTURING LTD. ....	152	MOROSO PERFORMANCE PRODUCTS INC. ....	114	SPAL AUTOMOTIVE USA .....	54
FITECH EFI. ....	83	MOTOR STATE DISTRIBUTING .....	35	SPECIALTY AUTO PARTS USA INC. ....	161
FLAMING RIVER INDUSTRIES INC. ....	81	NEO SYNTHETIC OIL CO INC. ....	154	SPECIALTY PRODUCTS COMPANY .....	80
FLUIDAMPR-VIBRATECH TVD .....	87	NICKELS PERFORMANCE DISTRIBUTORS .....	23,25,27	SPECIALTY PRODUCTS DESIGN .....	88
FR-TEAM INTERNATIONAL .....	116	NORTHERN RADIATOR .....	107	STIFFLERS .....	166
FUEL INJECTOR CLINIC .....	155	OTR FILTERS .....	158	THERMO-TEC .....	85
GANDRUD PARTS CENTER .....	141	P1 MANUFACTURING .....	169	THOMAS SALES CO. INC. ....	185
GOODYEAR TIRE & RUBBER CO. ....	6,7	PACIFIC PERFORMANCE ENGINEERING. ....	31	TOPLINE AUTOMOTIVE ENGINEERING .....	187
GRAND BENDING .....	119	PBM PERFORMANCE PRODUCTS .....	151	TOYO TIRES USA CORP. ....	9
H-P PRODUCTS .....	151	PENSKE RACING SHOCKS. ....	169	TRIBODYN LUBRICANTS .....	170
HALO BY ORTHENE .....	5	PERFORMANCE FORGE INC. ....	162	TURN 14 DISTRIBUTION INC. ....	3
HOT SHOT'S SECRET. ....	108	PERMATEX INC. ....	101	U.S. ARMY .....	29
HOWARDS CAMS .....	157	PETERSON FLUID SYSTEMS INC. ....	111	UNITED ENGINE & MACHINE CO. ....	89
HYPERMAX ENGINEERING INC. ....	136	PHILADELPHIA RACING PRODUCTS. ....	141	UNITED RACE PARTS LLC .....	153
IDIDIT LLC .....	163	PROREP MARKETING LLC. ....	185	UNITED WHEELS .....	113
INTERCOMP CO. ....	59	PYROTECT .....	159	VAC MOTORSPORTS .....	171
ISKY RACING CAMS .....	170	QUALCAST .....	105	VORTECH ENGINEERING INC. ....	155
ITALIAN TRADE AGENCY .....	121	QUANTUM MACHINERY GROUP .....	53	WALTON CO. ....	161
JAZ PRODUCTS INC. ....	79	QUICK PERFORMANCE .....	49	WEHRLI CUSTOM FABRICATION .....	82,103
JD SQUARED INC. ....	117	ROBINS MACHINES .....	13,15,17,19,21,169,172,181	WEINLE MOTORSPORTS .....	171
JESEL INC. ....	143	RON DAVIS RACING PRODUCTS INC. ....	156	WILWOOD ENGINEERING .....	11
JONES RACING PRODUCTS .....	69	ROSS RACING PISTONS .....	159	WOOLF AIRCRAFT PRODUCTS INC. ....	137
KAM MARKETING INC. ....	185	ROTTLER MANUFACTURING .....	188	XS POWER BATTERIES .....	138
KB CORES .....	51	S&S TRUCK PARTS. ....	147		
KUNZMAN & ASSOCIATES .....	184	SAMPSON .....	181		



# **HYLIFT JOHNSON LIFTERS**



## **DO YOU KNOW WHO MAKES YOURS?**

Hy Lift Johnson Lifter Co., the original Iconic brand, is the only global premier designer and manufacturer of engine lifters. Located in Muskegon, Michigan for over 85 years! We manufacture the most complete line of stock and high performance lifters in the industry! Hydraulic, Mechanical, Roller, Flats, Tie Bar Retro fit and Lash adjusters as well as Slow and Fast Leak Down versions and our Patented EDM Direct Shot® and Patent Pending Dual Float™ Bearing system. All made in the USA where Quality, Performance, Endurance and Engineering still matter!



## **THE ONLY COMPANY THAT DOES IT ALL!**

As Topline celebrates 50 years of supplying quality import engine parts, we look forward to continuing our tradition of building strong relationships with our customers by delivering dependable, reliable service.

***TopLine***  
Automotive Engineering, Inc.  
Parts and Components

**PRISHOW**  
BOOTH 641

Topline truly embodies the spirit of innovation, integrity, trust and excellence. We understand that success doesn't come from what is done occasionally, but from what is done consistently. We pride ourselves on this commitment. Our products are sold and recommended by the most knowledgeable, experienced and trusted engine builders and parts distributors in the world.

800-441-1400 | [TOPLINEAUTO.COM](http://TOPLINEAUTO.COM)

Copyright 2023 Topline Automotive

# WIN WITH RÖTTLER!

# EM69HP

**AUTOMATICALLY DIGITIZE PORTS AND  
CYLINDERS WITH THE MOST ADVANCED  
MACHINING CENTER IN THE WORLD**



**ENGINE**  
**PERFORMANCE**  
**EXPO**

Hands-on education, information and Q & A with the Performance Engine industry's leading manufacturers, suppliers and engine builders - Now available at your convenience! [engineperformanceexpo.com](http://engineperformanceexpo.com)

**RÖTTLER**

**ROTTLERMFG.COM 1-800-452-0534**